

Sensor and Simulation Notes

Note XLII

31 May 1967

note 42

done

A Conical-Transmission-Line Gap for a Cylindrical Loop

Capt Carl E. Baum  
Air Force Weapons Laboratory

Abstract

The signal cable loads along the gaps of a single-gap or multi-gap cylindrical loop may not, in many cases, make a good approximation to an ideal continuous load distribution. In such cases it may be desirable to design the loop gap to partially compensate for the discrete load distribution. One approach consists of making the loop gap near a load position approximate a conical transmission line with a pulse impedance equal to the load resistance at the position of interest.

PL/PA 10/27/94

PL 94-0912

## I. Introduction

In designing  $\dot{B}$  loops for high frequency response it is often desirable to use a cylindrical loop. For a given cross section area one can increase the length of the cylinder, thereby decreasing the inductance.<sup>1</sup> The cylindrical loop can be designed to measure  $\dot{B}$  for frequencies for which the radian wavelength (in an external medium of negligible conductivity) is greater than the loop radius.<sup>2,3</sup> If the length,  $\ell$ , of the loop is much greater than the loop radius,  $a$ , and if all the loop parameters, including the resistive loading of the loop gaps due to the signal cables, are uniform along the loop axis then one can solve for the loop response as a two-dimensional problem. Practically, however, it may be difficult to have all the pertinent loop parameters distributed uniformly along the loop axis. In particular, it may be impractical to uniformly distribute the resistive loading of the signal cables along the loop gaps.

Ideally, the spacing between the signal cable loads along the gap is small compared to the loop radius, but even this may be difficult to achieve in many cases for practical cable impedances. A more common situation would involve a small number of loading positions on the loop gaps. For example, consider the single-gap cylindrical loop with two load positions at the loop gap as illustrated in figure 1A. Each load position can be associated with a certain part of the loop gap which we might call a unit cell of the loop gap. Figure 1B gives an expanded view of such a unit cell of width,  $2d$ . The load resistance,  $R$ , connecting across the gap is the resistive load associated with the signal cable(s) connecting across the gap at that position. The load resistance is assumed to be centered in the unit cell. For convenience we center a cartesian  $(x, y, z)$  coordinate system on the load resistance with the  $z$  axis parallel to the loop axis. The loop structure is assumed approximately flat in the vicinity of the loop gap and this defines the  $(x, z)$  plane. For the example in figure 1A the length of the loop would be  $\ell = 4d$ . The unit cell as in figure 1B, however, applies to the general case of both single-gap and multi-gap cylindrical loops.

Given a certain width of the unit cell one might try to design the geometry of the loop gap so as to minimize any adverse effects on the frequency response characteristics of the loop associated with the discrete load positions. Consider the case that there is only one electromagnetic medium in the vicinity of the loop (excluding the loop structure) and that this medium has negligible conductivity. Then we might roughly picture the loop gap as having a capacitance associated with it. Since the discrete resistive loads constrict the current flowing across the gaps to narrow paths we might also associate an inductance with the load positions, increasing the inductance of the sensor above the inductance for the case of a uniform load distribution along the loop gap. One might make the gap width,  $2b$ , small in order to minimize this added inductance, but in

1. Lt Carl E. Baum, Sensor and Simulation Note VIII, Maximizing Frequency Response of a  $\dot{B}$  Loop, December 1964.

2. Capt Carl E. Baum, Sensor and Simulation Note XXX, The Single-Gap Cylindrical Loop in Non-Conducting and Conducting Media, January 1967.

3. Capt Carl E. Baum, Sensor and Simulation Note XLI, The Multi-Gap Cylindrical Loop in Non-Conducting Media, May 1967.

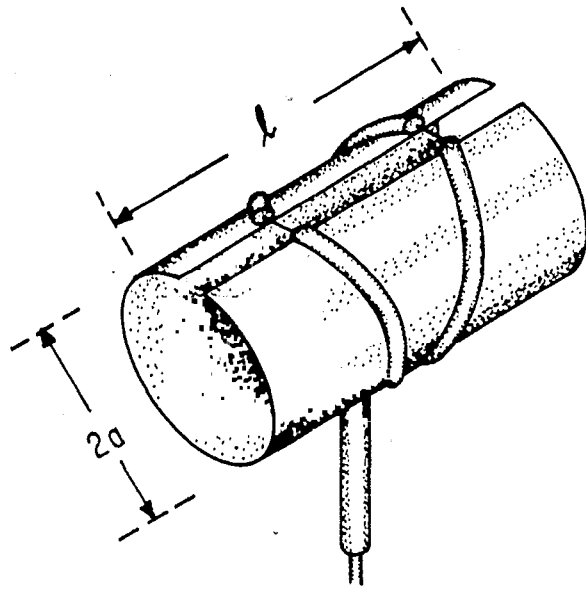

A. SINGLE-GAP CYLINDRICAL LOOP: ANGULAR VIEW

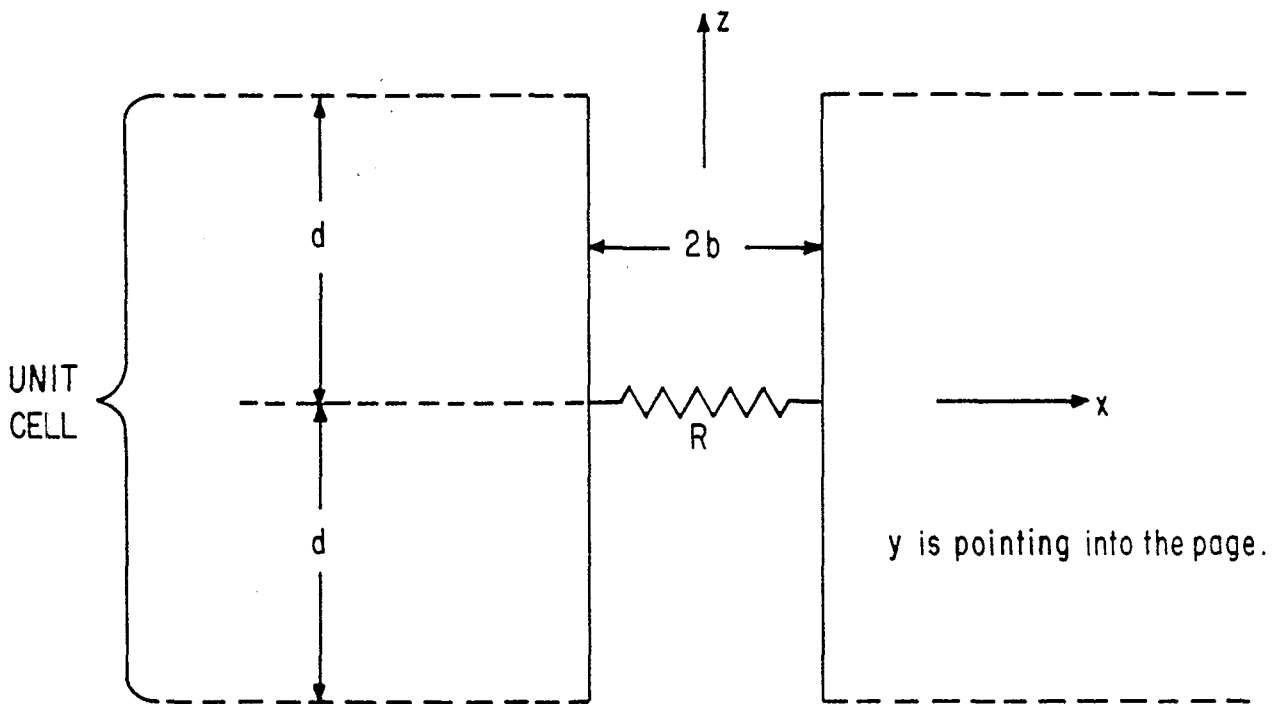

B. UNIT CELL OF LOOP GAP: EXPANDED VIEW

FIGURE 1. CYLINDRICAL LOOP WITH DISCRETE LOADS

so doing the gap capacitance is increased. Perhaps there is some value of  $b$  which is optimum for the response characteristics of the loop, balancing the capacitance and inductance. Or, perhaps the shape of the loop gap can be changed to further minimize the effects of the capacitance and extra inductance. We consider one such approach in this note.

## II. Conical-Transmission-Line Gap

Instead of a gap of uniform width,  $2b$ , as in figure 1B, consider a gap of nonuniform width. If we consider the unit cell (a part of the loop structure) as in figure 2A, to be approximately flat in the vicinity of the loop gap, then this loop gap is a conical transmission line with its apex at the load resistance. This particular conical transmission line is one which lies in a single plane. There are various possible types of conical transmission lines which we might consider for the loop gap, but we choose one of the simpler ones for convenience.

Consider, then, a conical transmission line consisting of two flat conductors, lying in the  $(x, z)$  plane. Let a spherical coordinate system  $(\rho, \theta, \phi)$  be centered on the apex of the conical transmission line, with  $\theta = 0$  corresponding to the positive  $z$  axis and  $\phi = 0$  corresponding to the  $(x, z)$  plane for positive  $x$ . The two edges of both conductors are defined (ideally) by  $\theta = \theta_0$  and  $\theta = \theta_1 = \pi - \theta_0$ . As illustrated in figure 2A, the conical-transmission-line gap is symmetric with respect to the  $(y, z)$  plane, the  $z$  axis being the center of the loop gap. It is also symmetric with respect to the  $(x, y)$  plane. The structure is a conical transmission line only for distances close enough to the apex that the conical geometry is maintained. As one considers distances along the conductors progressively farther from the apex the curvature of the loop structure becomes significant and the edges of the unit cell are met. For such positions far from the apex one may wish to modify the shape of the structure to partially compensate for these nonideal effects. Near the apex, however, the conical-transmission-line gap is capable of supporting what is approximately a spherical TEM field distribution.

The reason for making the loop gap approximate a conical transmission line is that the gap has a well-defined pulse impedance,  $Z_g$ , which can be matched to the load resistance,  $R$ . Such a transmission line has a certain capacitance and inductance for a given length, and we might use these to estimate the capacitance and added inductance associated with the loop gap. By making the loop gap as a conical transmission line we can try to balance this capacitance and inductance by our choice of  $Z_g$  which is a function of  $\theta_0$  and the permittivity and permeability of the medium in which the loop operates. Setting  $Z_g = R$ , one can match TEM waves on the conical structure, which are propagating toward the apex, into the signal cables with insignificant reflection. One might also roughly think of this kind of loop gap as smoothly directing the current in the loop structure into the signal cables. Note, however, that the transit time along the loop structure to the nearest load position is still a function of position along the length of the cylindrical loop. Thus, the conical-transmission-line loop gap would seem to be only an approximate solution to the problem of discrete load positions.

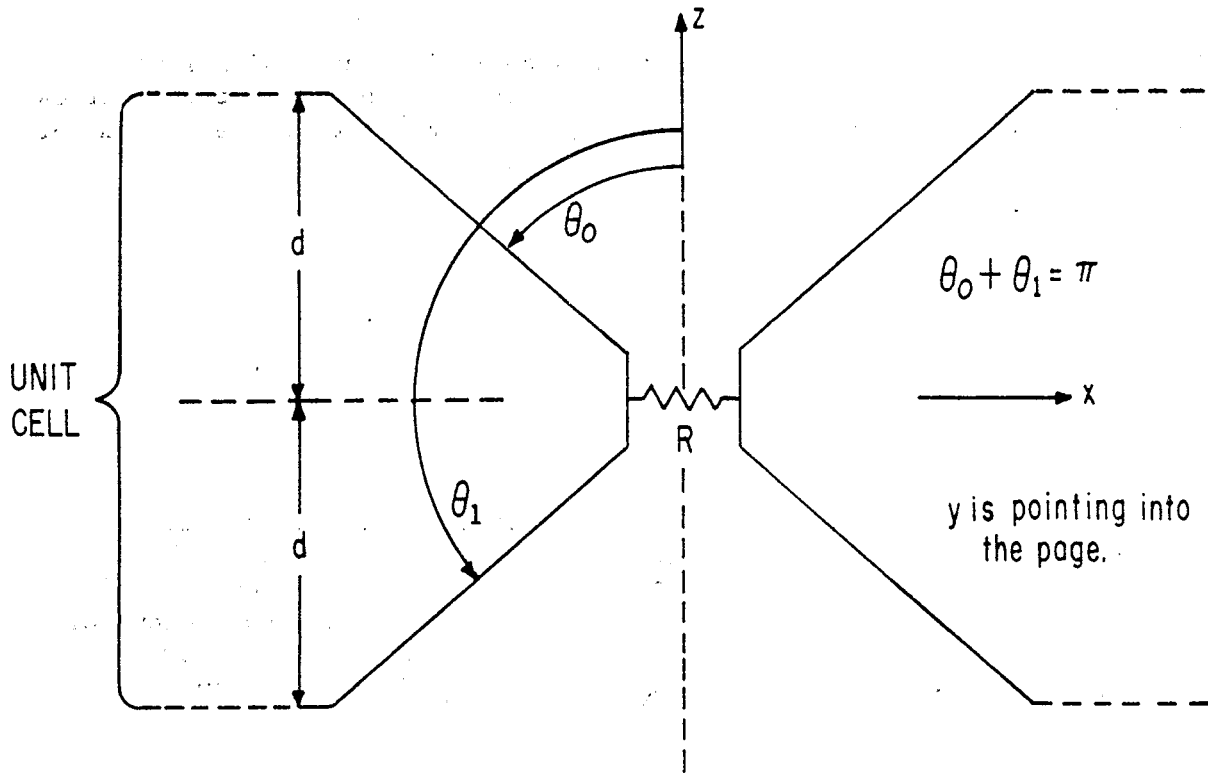

A. UNIT CELL OF LOOP GAP EXPANDED VIEW

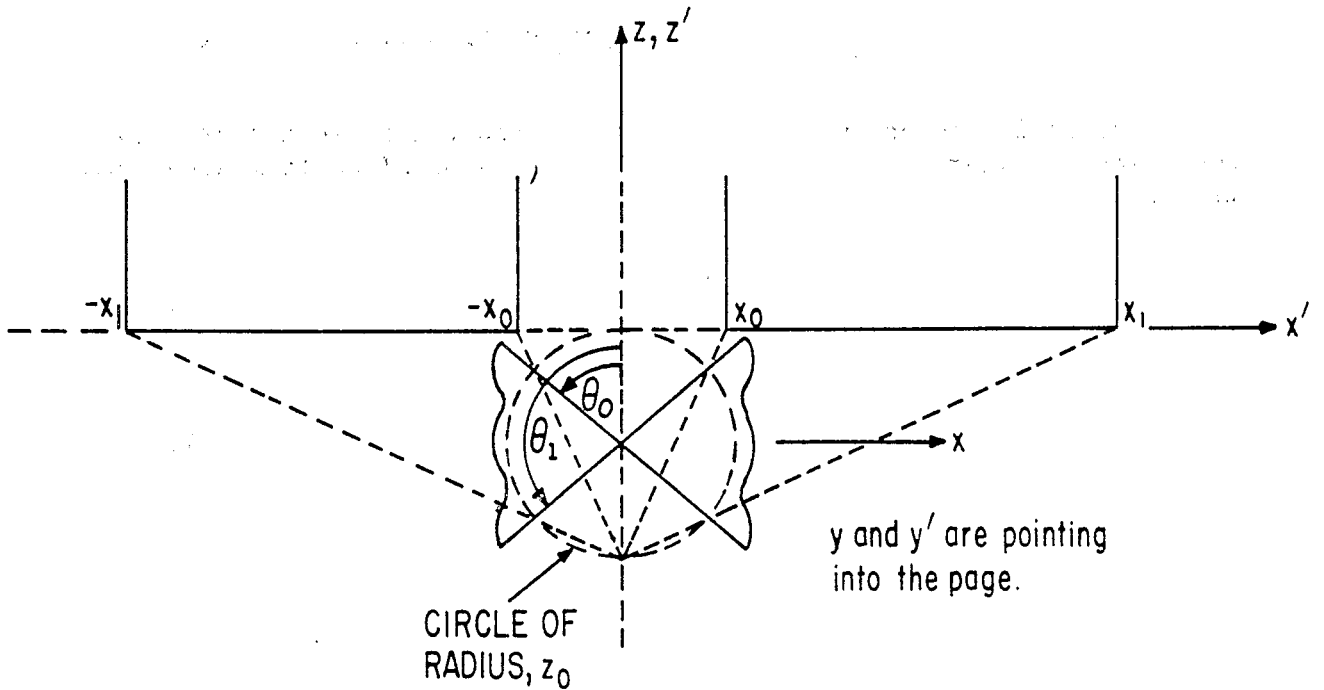

B. TRANSFORMATION TO EQUIVALENT CYLINDRICAL TRANSMISSION LINE

FIGURE 2. SYMMETRICAL CONICAL TRANSMISSION LINE FOR LOOP GAP

Since this loop gap is approximated as a conical transmission line, its impedance can be determined by transforming it to an equivalent cylindrical transmission line. Considering a cartesian  $(x', y', z')$  coordinate system for the equivalent cylindrical transmission line we have the transformation equations<sup>4</sup>

$$x' = 2z_0 \cos(\phi) \tan\left(\frac{\theta}{2}\right) \quad (1)$$

$$y' = 2z_0 \sin(\phi) \tan\left(\frac{\theta}{2}\right) \quad (2)$$

and

$$z' = \rho' \quad (3)$$

where  $z_0$  is an arbitrary constant. This transformation of the conical transmission line is illustrated in figure 2B. We have chosen the spherical coordinate system such that the conductors lie on a plane given by a  $\phi$  of 0 or  $\pi$ . Thus, in the equivalent cylindrical transmission line the conductors are parallel strips in the  $(x', z')$  plane. The inner edges of the strips are at  $x' = \pm x_0$  and the outer edges are at  $x' = \pm x_1$  where from equation (1) we have

$$x_0 = 2z_0 \tan\left(\frac{\theta_0}{2}\right) \quad (4)$$

and

$$x_1 = 2z_0 \tan\left(\frac{\theta_1}{2}\right) = 2z_0 \tan\left(\frac{\pi - \theta_1}{2}\right) = 2z_0 \cot\left(\frac{\theta_0}{2}\right) \quad (5)$$

The field and potential distributions and the impedance of this equivalent cylindrical transmission line can be obtained from a conformal transformation given by<sup>5,6</sup>

$$\frac{x' + jy'}{x_0} = \text{sn}(w|m) \quad (6)$$

where

$$w = u + jv \quad (7)$$

4. W. R. Smythe, Static and Dynamic Electricity, 2nd ed., 1950, p. 479.

5. Moon and Spencer, Field Theory Handbook, 1961, p. 71.

6. See AMS 55, Handbook of Mathematical Functions, National Bureau of Standards, 1964, for the notation regarding the elliptic integrals and the Jacobian elliptic functions.

The equipotentials and magnetic field lines are given by lines of constant  $u$ . The pulse impedance,  $Z_g$ , of the transmission line is related to the wave impedance,  $Z$ , of the medium in which the wave propagates by

$$Z_g = f_g Z \quad (8)$$

where  $f_g$  is a dimensionless geometric constant. This constant is given by

$$f_g = \frac{K(m)}{K(m_1)} \quad (9)$$

where

$$m = 1 - m_1 = \left( \frac{x_0}{x_1} \right)^2 \quad (10)$$

To solve for the pulse impedance of the conical transmission line substitute from equations (4) and (5) giving

$$m = \tan^4 \left( \frac{\theta_0}{2} \right) \quad (11)$$

Taking the wave impedance as that of free space,  $Z_0$ , or about 377 ohms, the impedance of the conical transmission line is plotted as a function of  $\theta_0$  in figure 3. This data is also included in the following table for some convenient values of  $Z_g$  based on convenient cable impedances and on multiples and submultiples of such cable impedances.<sup>7</sup>

$Z_g$ (ohms)	$f_g$	$\frac{x_0}{x_1}$	$\theta_0$ (radians)	$\theta_0$ (degrees)	$\tan(\theta_0)$
25	.0664	$2.099 \times 10^{-10}$	$2.898 \times 10^{-5}$	$1.660 \times 10^{-3}$	$2.898 \times 10^{-5}$
50	.1327	$2.898 \times 10^{-5}$	.01077	.617	.01077
75	.1991	$1.498 \times 10^{-3}$	.0774	4.432	.0775
100	.2654	.01077	.2068	11.85	.2098
125	.332	.0351	.371	21.24	.389
150	.398	.0773	.542	31.1	.603
200	.531	.2053	.851	48.8	1.140
250	.664	.362	1.084	62.1	1.887
300	.796	.516	1.246	71.4	2.969
400	1.062	.752	1.429	81.9	6.99
500	1.327	.884	1.509	86.5	16.16
600	1.593	.948	1.544	88.5	37.2
800	2.124	.990	1.566	89.7	197.4

Table I. Pulse Impedance for Conical Transmission Line

7. In Sensor and Simulation Note XXI the values of  $f_g$  for some of these same impedances are low by a relative amount of about  $2 \times 10^{-3}$ .

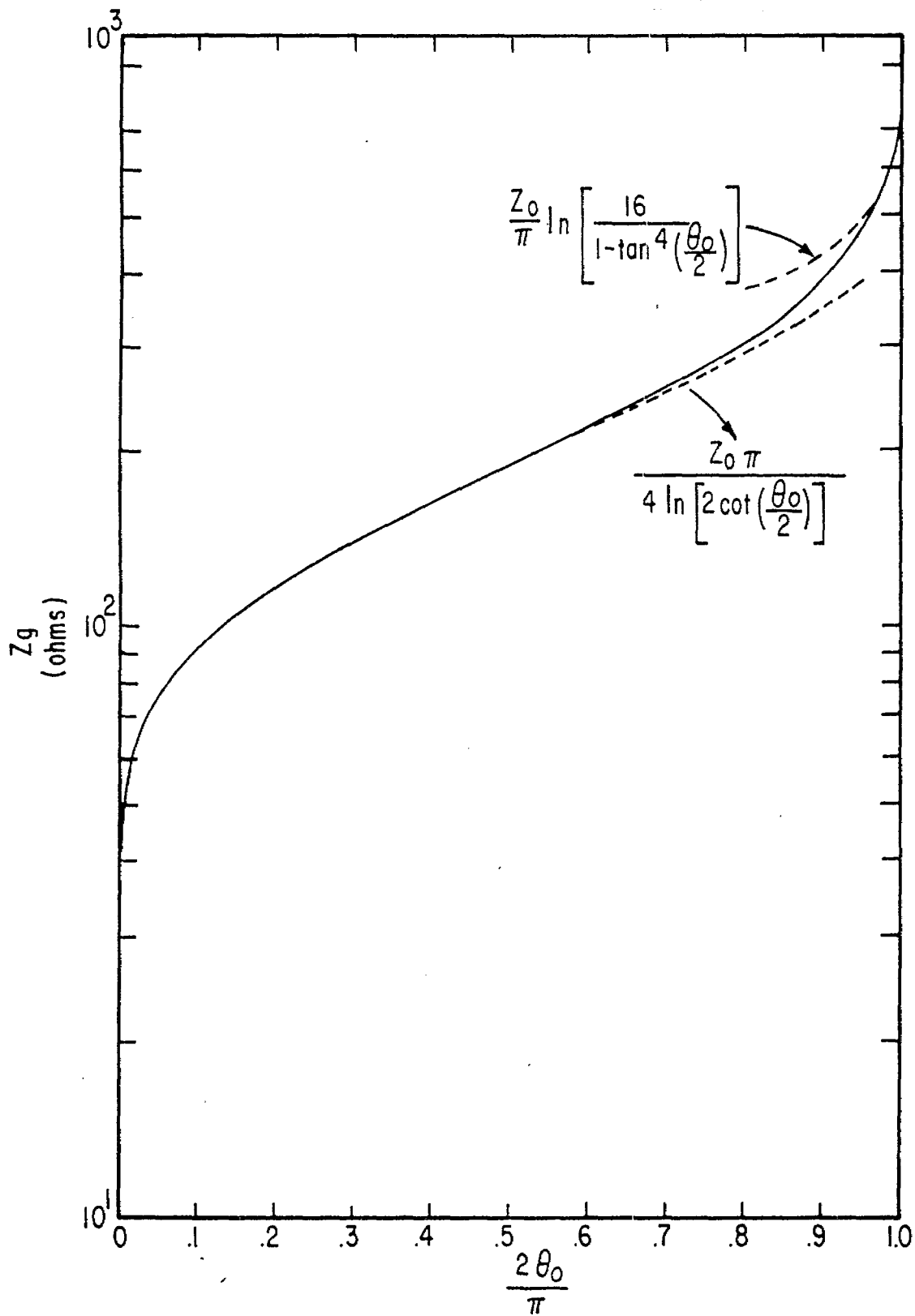

FIGURE 3. PULSE IMPEDANCE OF CONICAL TRANSMISSION LINE



There are limiting forms for this pulse impedance. For  $\theta_0 \ll 1$ , which corresponds to  $m \ll 1$ , the geometric impedance factor is

$$f_g = \frac{\pi}{\ln\left(\frac{16}{m}\right)} = \frac{\pi}{2 \ln\left(\frac{4x_1}{x_0}\right)} = \frac{\pi}{4 \ln\left[2 \cot\left(\frac{\theta_0}{2}\right)\right]} \quad (12)$$

For  $\theta_0$  close to  $\pi/2$ , which corresponds to  $m_1 \ll 1$ ,  $f_g$  is given by

$$f_g = \frac{1}{\pi} \ln\left(\frac{16}{m_1}\right) = \frac{1}{\pi} \ln\left[\frac{16}{1 - \left(\frac{x_0}{x_1}\right)^2}\right] = \frac{1}{\pi} \ln\left[\frac{16}{1 - \tan^4\left(\frac{\theta_0}{2}\right)}\right] \quad (13)$$

These approximate forms are included in figure 3, indicating their respective ranges of validity.

### III. Summary

It may be necessary to have the resistive loads associated with the signal cables placed at discrete positions on the gap(s) of a cylindrical loop. Something approaching a continuous distribution of such loads may be impractical in many cases. Then it may be desirable to minimize adverse effects of the discrete load distribution by an appropriate loop-gap design. One approach to this loop-gap design consists of making the loop gap, at least near a load position, in the form of a conical transmission line with the same pulse impedance as the load resistance at the load position of interest.

We would like to thank Mr. John N. Wood for the numerical calculations and the resulting graph.