

Sensor and Simulation Notes

Note 457

6 June 2001

Differential Switched Oscillators and Associated Antennas

**Carl E. Baum
Air Force Research Laboratory
Directed Energy Directorate**

Abstract

This paper extends the design options for switched-oscillator-driven paraboloidal reflector antennas to include differential systems. The switched oscillator can be differential or single-ended with a balun. The full reflector with TEM feed arms can be driven in various ways to give a variety of polarizations from the switched oscillator located at the paraboloid focus, or on the paraboloid with a transmission line to the focus.

This work was sponsored in part by the Air Force Office of Scientific Research, and in part by the Air Force Research Laboratory, Directed Energy Directorate.

1. Introduction

Recent papers [7, 8] have considered switched oscillators and associated antennas for radiating an oscillatory waveform. The antennas [7] considered thus far are of the single-ended variety involving a ground plane with a half-paraboloidal reflector together with feed arms as in a reflector impulse-radiating antenna (IRA) [2]. This geometry has the advantage of matching well with single-ended (e.g., coaxial) pulse-power systems and providing a place for the pulse-power equipment on the side of the ground plane (typically under) away from the antenna.

For some applications a differential source and antenna may be desired, and a half-reflector-with-ground-plane antenna may not be appropriate. Among the applications are linear-polarization diversity and circular polarization. This raises difficulties in how to feed the pulse power to the antenna.

2. Differential Switched Oscillators

As discussed in [8] switched oscillators can in principle be single-ended or differential. Differential ones, however, encounter some difficulties. One approach as in Fig. 2.1 is to place two coaxial single-ended switched oscillators side by side with a single differential switch. This single switch is important so that we don't have to be concerned with the two switches (one plus, one minus) firing at not precisely the same times (jitter or spread). Note that each half is $\lambda/4$ in length (for an overall length of $\lambda/2$, switched in the center). For connection to the antenna without charging the antenna arms to $\pm V_0$ there is a blocking capacitance of C_b [7] achieved by two of value $2 C_b$.

The two single-ended switched oscillators can also be placed in a common outer shield to give a twinaxial version as illustrated in Fig. 2.2. In this case the two high-voltage electrodes can be flattened where they face each other to lower the differential transmission-line impedance and store more energy in the central region between the two conductors.

Both of the foregoing differential switched oscillators suffer from significantly increased complexity around the switch, particularly if a high-pressure gas switch is used. A single-ended body-of-revolution switched oscillator allows a body-of-revolution switch with coaxial rotation symmetry in the mechanical forces required to hold the pressure. Perhaps a single-ended switched oscillator can be adapted for differential use.

Figure 2.3 shows a kind of balun that one might use to convert a single-ended switched oscillator to a differential output. In this case we have a sleeve balun [10]. This is a narrow band device which needs to be tuned to the oscillator frequency by making it a quarter wavelength ($\lambda/4$) long at this frequency. Define

$$Z_{c1} \equiv \text{characteristic impedance of coax forming switched oscillator} \quad (2.1)$$

$$Z_{c2} \equiv \text{characteristic impedance of coax (between oscillator shield and additional outer shield) forming balun}$$

for the two characteristic impedances of the triaxial structure [1]. The function of the balun is to present an open circuit at the oscillator frequency f_0 where the oscillator output leaves the balun. This open circuit prevents current from flowing on the outside of the balun, thereby forcing the sum of the currents leaving the two connections to the oscillator output to be zero (i.e., differential). Note in this case that the blocking capacitor need only be connected to the central conductor charged to V_0 . The first shield is at zero potential during the charging (the balun not being effective at low frequencies).

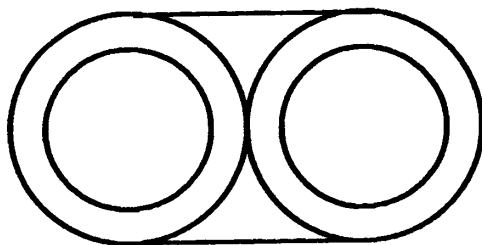

A. End view

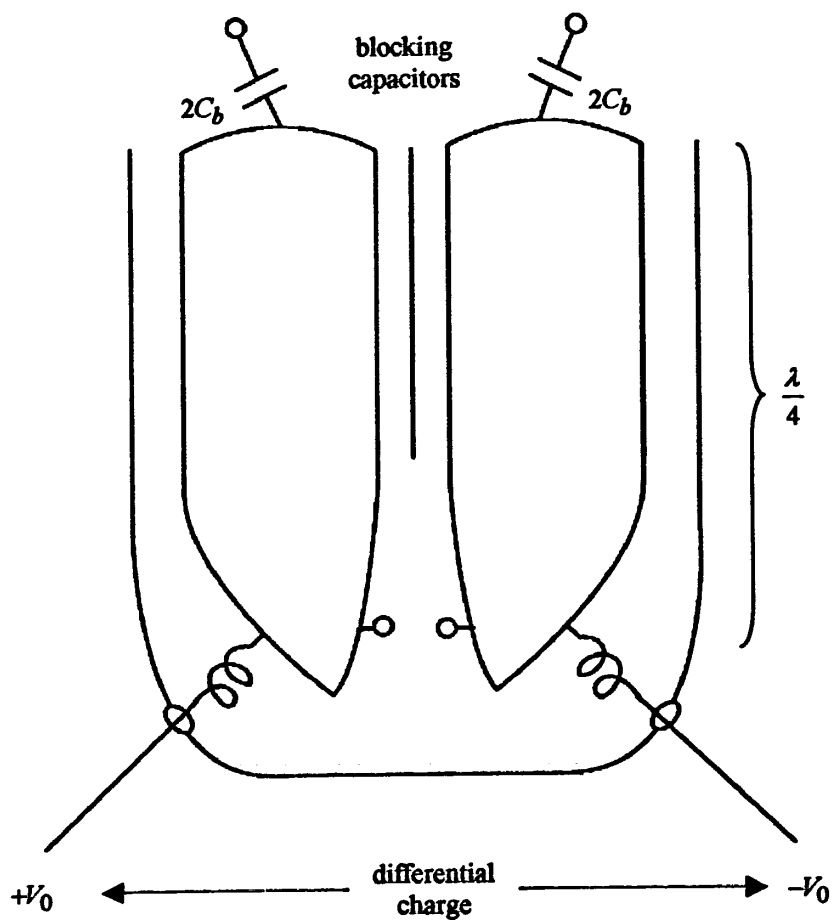

B. Side view (cross section)

Fig. 2.1 Two Switched Oscillators with Common Switch

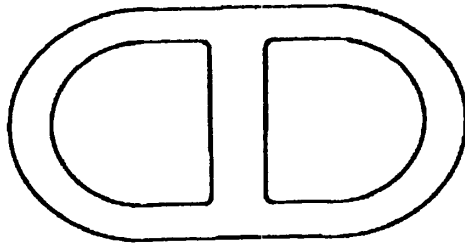

A. End view

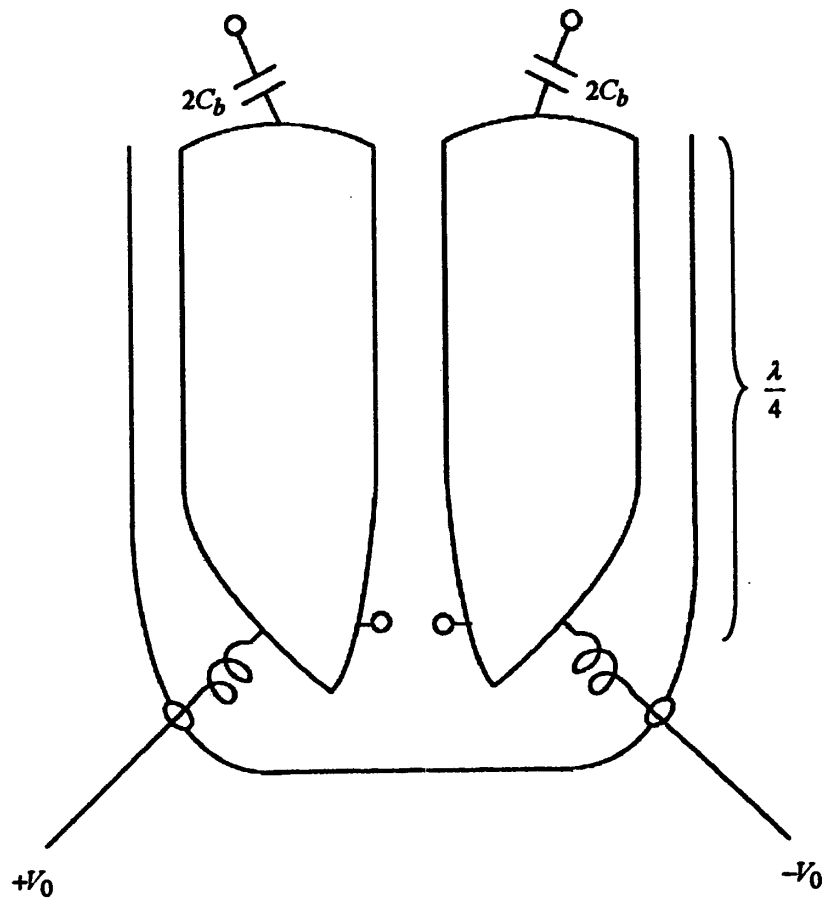

B. Side view (cross section)

Fig. 2.2 Twinaxial Switched Oscillator

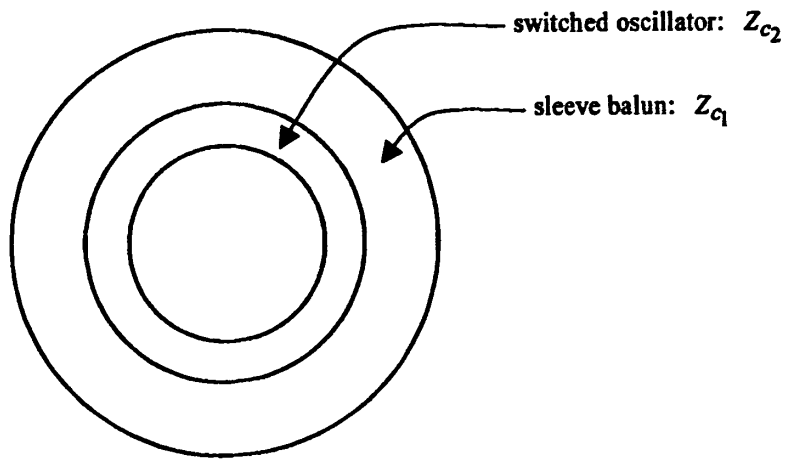

A. End view

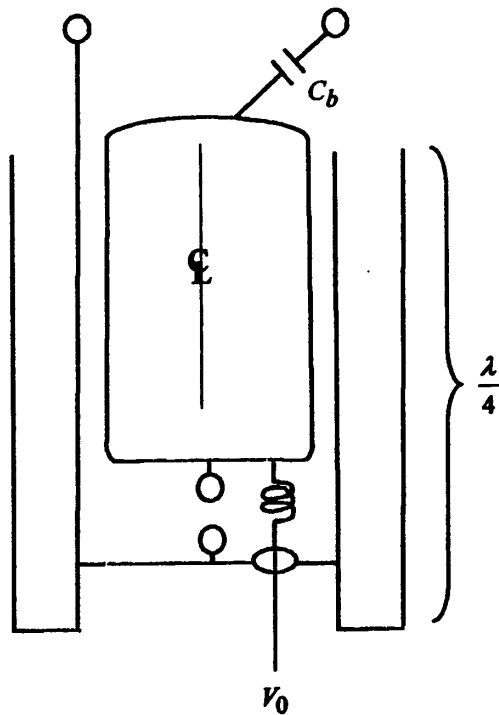

B. Side view (cross section)

Fig. 2.3 Single-Ended Switched Oscillator with Sleeve Balun

We still have some freedom in our choice of Z_{c_2} . With Z_{c_1} typically chosen small for large energy storage, Z_{c_2} can be chosen somewhat larger to increase the balun impedance in the band around f_0 . For frequencies significantly below f_0 the balun is ineffective and the source is no longer differential.

Another type of balun is a choke made of magnetic materials (e.g., ferrite) surrounding the oscillator. However, for high-power applications one may be concerned with problems of frequency response and saturation of the material.

3. Feed to Antenna

The antenna type of concern being a TEM-fed paraboloid we have an oscillator reflector antenna (ORA) for our consideration. One form of this places the oscillator near the paraboloidal focus as in Fig. 3.1. The single-ended oscillator with sleeve balun as in Fig. 2.3 is shown here, but the differential forms in Figs. 2.1 and 2.2 can be used as well.

This configuration is similar to the impulse-radiating antenna (IRA) in [9]. While a full reflector is fed in a differential manner, there are various problems to consider. The oscillator and balun provided some blockage to the wave leaving the reflector. There is also the mechanical problem of supporting the oscillator without introducing supports (especially conducting supports) which interfere with the wave. Note that with the electric field polarized so that it is perpendicular to the $x = 0$ plane everywhere on this plane (symmetry), this plane can contain conductors which are part of this support structure. As the case in [9], the high-voltage feed to the oscillator also follows this plane from behind the reflector.

An alternate location for the oscillator is behind the reflector on the reflector axis as indicated in Fig. 3.2A. Note that the outermost conductor of the balun, or of the oscillator for differential types, is circumferentially bonded to the reflector. This can also provide mechanical support for the reflector. The high-voltage power supply behind the reflector is now closer to the switched oscillator.

Now we need a transmission line to feed the signal from the oscillator to the paraboloid focus to drive the antenna feed arms (conical transmission line of characteristic impedance Z_c). This (cylindrical) transmission line should also have characteristic impedance Z_c to minimize reflections at the focus. This transmission line can have various possible configurations. As a differential twinline it can have two polarities retaining the antenna symmetry as in Fig. 3.2B. In one case the two conductors cross over to connect the conductors to the antenna feed. Now since such an open transmission line can itself radiate, influencing the net antenna radiation, one may wish to suppress this additional radiation. As shown in Fig. 3.2C one can have a quadline which has no net dipole moments per unit length to suppress such radiation. Appropriate conductors are connected together at the oscillator and at the antenna feed. Note that high-voltage insulation may be needed around this feed to the focus. One would like the conductor spacings small to minimize radiation, but large enough for sustaining low-loss transmission of the high-voltage signal.

This type of cylindrical-transmission-line to conical-transmission-line feed structure has some similarities to the feed of a Cassegrain reflector antenna. The Cassegrain geometry sends a beam through the center of the reflector to a secondary hyperboloidal reflector near the paraboloid focus, which in turn expands the reflected beam to fill the paraboloid. A variant of this has a center conductor to guide the first beam toward the secondary reflector [3, 5]. For the present transmission-line variety we are considering somewhat lower frequencies than are typically used in Cassegrain antennas, so that transmission-line guiding structures become appropriate.

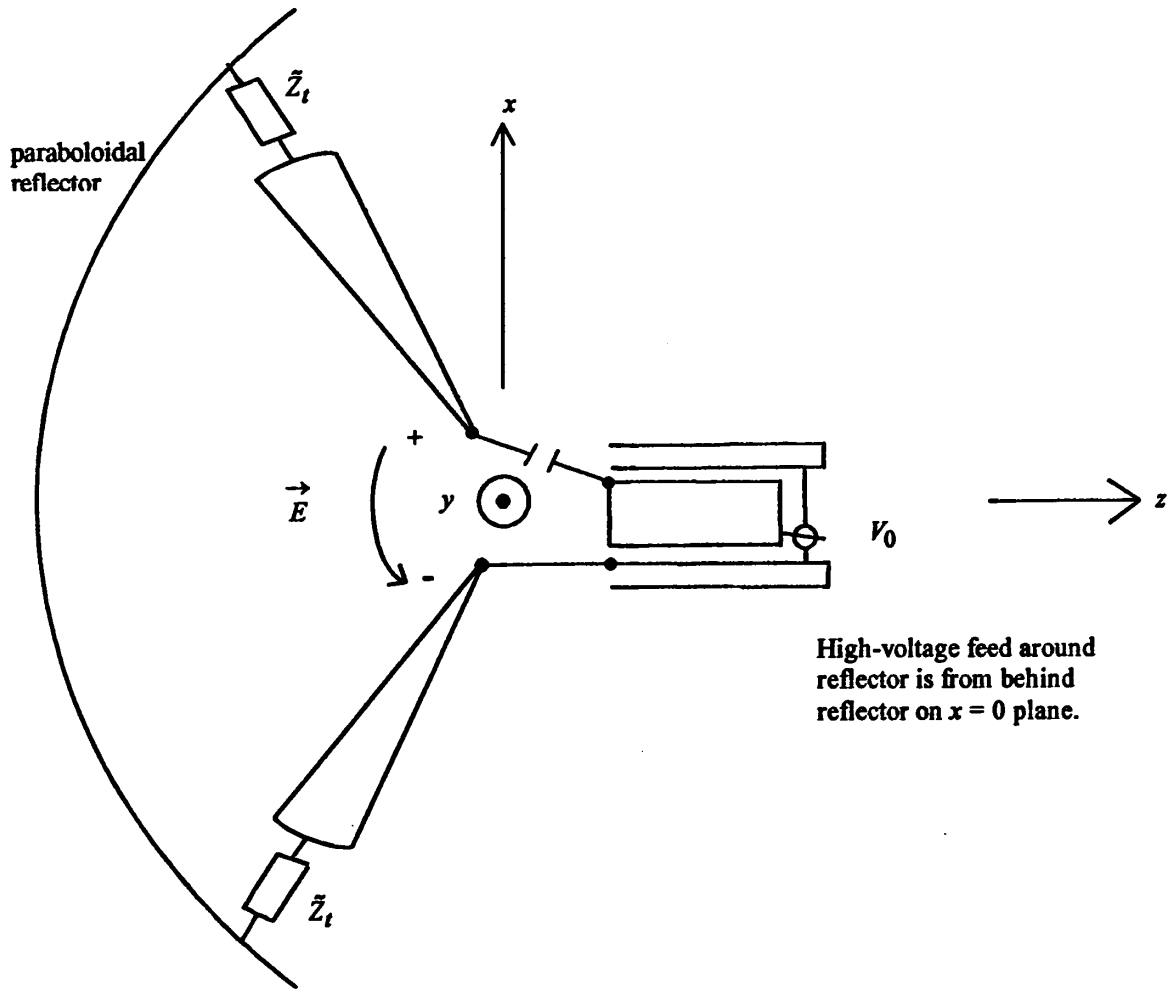

Two of four feed arms are shown.
 Net termination impedance is \tilde{Z}_t .
 Feed impedance is Z_c .

Fig. 3.1 Oscillator Near Paraboloid Focus

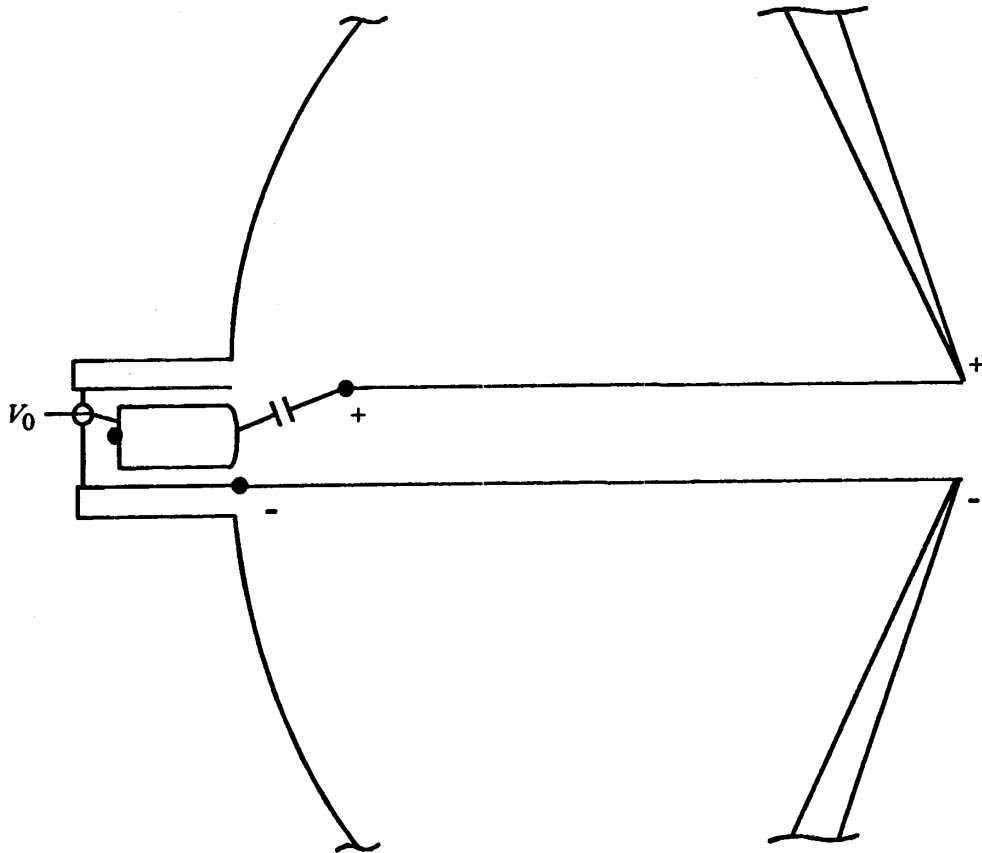

A. Oscillator feed to focus



or

(crossing near focus)



B. Twin feed to focus



C. Quad feed to focus



Fig. 3.2 Oscillator Mounted Behind Reflector

4. Antenna Polarization

With a differential full reflector, another degree of flexibility is introduced, namely in polarization. For the typical four-arm-fed reflector with orthogonal arm pairs (arm planes separated by $\pi/2$), a single arm pair has a characteristic impedance

$$Z_f = Z_f^{(2)} \quad (4.1)$$

typically of 400 Ω . When connected in parallel as in Fig. 4.1A this changes to

$$Z_f = Z_f^{(4)} = \frac{1}{2} Z_f^{(2)} \quad (4.2)$$

typically of 200 Ω .

A single linear polarization with feed impedance $Z_f^{(4)}$ is illustrated in Fig. 4.1A. By connecting two independent feed signals V_1 and V_2 to orthogonal arm pairs we can have two orthogonal polarizations, each with feed impedance $Z_f^{(2)}$, as illustrated in Fig. 4.1B.

A special case of circular polarization can be achieved as illustrated in Fig. 4.1C. In this case a voltage V drives the two arm pairs through separate networks. Arm-pair 1 has a voltage V_1 after passing through a net capacitance C_t (t for turnstile) as

$$\frac{\bar{V}_1}{\bar{V}} = \frac{Z_f^{(2)}}{Z_f^{(2)} + [sC_t]^{-1}} \quad (4.3)$$

$\bar{\sim} \equiv$ two-sided Laplace transform over time t

$s = \Omega + j\omega \equiv$ Laplace-transform variable or complex frequency

Similarly, arm-pair 2 has a voltage V_2 after passing through a net inductance L_t as

$$\frac{\bar{V}_2}{\bar{V}} = \frac{Z_f^{(2)}}{Z_f^{(2)} + sL_t} \quad (4.4)$$

The parallel combination of the two arm pairs now has an admittance

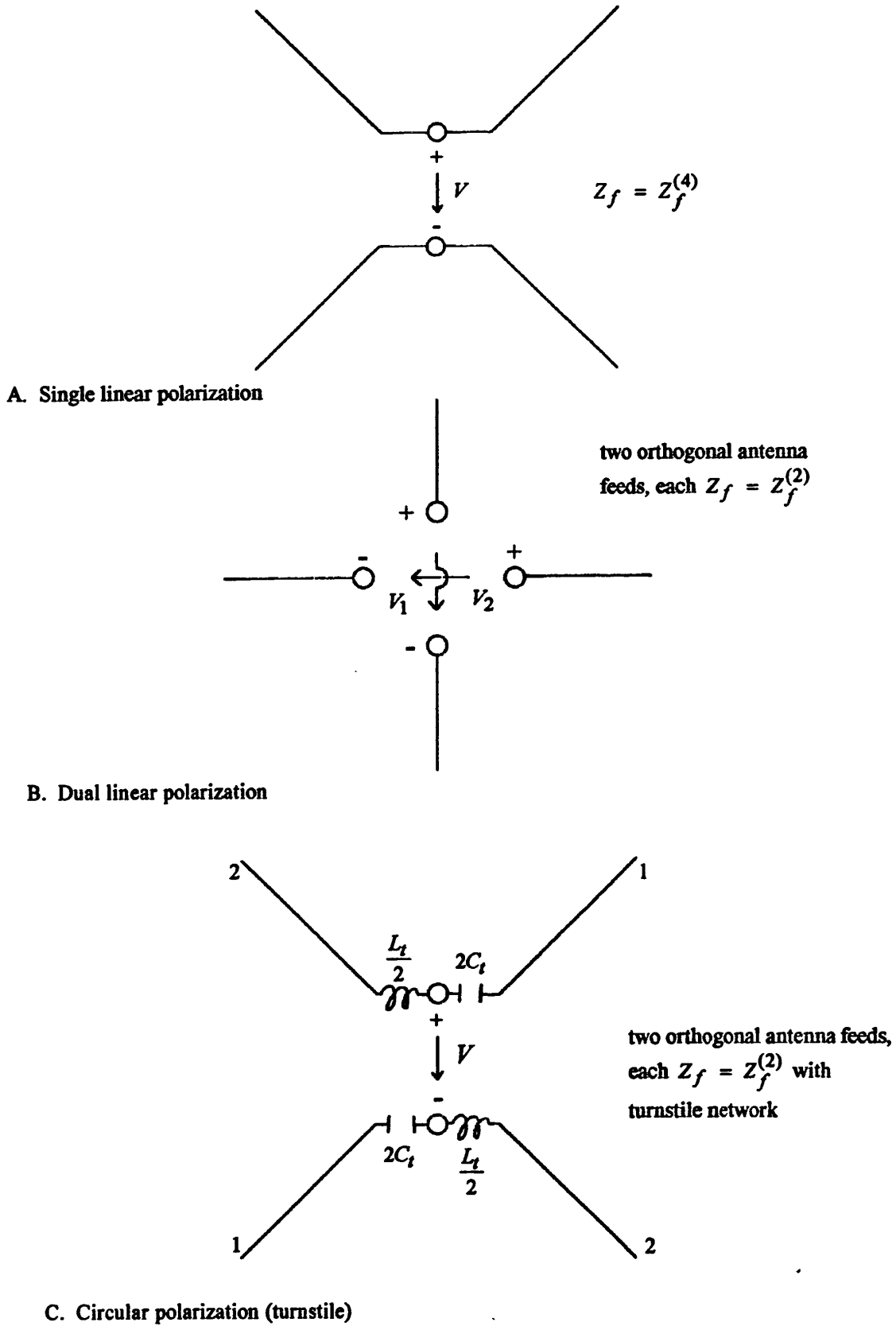

Fig. 4.1 Connection to Feed Arms for Various Polarizations

$$\begin{aligned}\bar{Y} &= \frac{\bar{V}}{\bar{I}} = \left[Z_f^{(2)} + [sC_t]^{-1} \right]^{-1} + \left[Z_f^{(2)} + sL_t \right]^{-1} \\ &= Z_f^{(2)-1} \left[\left[1 + [sC_t Z_f^{(2)}]^{-1} \right]^{-1} \left[1 + \frac{sL_t}{Z_f^{(2)}} \right]^{-1} \right]\end{aligned}\quad (4.5)$$

Constraining

$$\tau = C_t Z_f = \frac{L_t}{Z_f^{(2)}} \quad (4.6)$$

we have the special case of an all-pass network with

$$\bar{Y} = Z_f^{(2)-1} \left[\frac{s\tau}{s\tau+1} + \frac{1}{s\tau+1} \right] = Z_f^{(2)-1} \quad (4.7)$$

with frequency-independent impedance $Z_f^{(2)}$.

Returning to the voltages on the two arm pairs we have

$$\frac{\bar{V}_1}{\bar{V}} = \frac{s\tau}{s\tau+1}, \quad \frac{\bar{V}_2}{\bar{V}} = \frac{1}{s\tau+1} \quad (4.8)$$

At the selected radian frequency ω_0 (e.g., from the switched oscillator) the two voltages have the same magnitude

$$\left| \frac{\bar{V}_1}{\bar{V}} \right| = \frac{\omega_0 \tau}{|j\omega_0 \tau + 1|} = \left| \frac{\bar{V}_2}{\bar{V}} \right| = \frac{1}{|j\omega_0 \tau + 1|} \quad (4.9)$$

provided

$$\omega_0 \tau = 1 \quad (4.10)$$

thereby constraining both L_t and C_t from (4.6).

Now consider the two phases as

$$\begin{aligned}
\arg\left(\frac{\tilde{V}_1}{\tilde{V}}\right) &= \frac{\pi}{2} - \arg(j + 1) = \frac{\pi}{4} \\
\arg\left(\frac{\tilde{V}_2}{\tilde{V}}\right) &= -\arg(j + 1) = -\frac{\pi}{4} \\
\arg\left(\frac{\tilde{V}_1}{\tilde{V}}\right) - \arg\left(\frac{\tilde{V}_2}{\tilde{V}}\right) &= \frac{\pi}{2}
\end{aligned}
\tag{4.11}$$

Thus the two arm pairs are in phase quadrature to give circular polarization. This gives a special kind of turnstile antenna.

The reader should note that the dual-polarization (Fig. 4.1B) and circular-polarization (Fig. 4.2C) require the two arm pairs to be orthogonal, (i.e., on orthogonal planes, e.g., $\phi_0 = \pm 45^\circ$ or $\phi_0 = 0^\circ, 90^\circ$ [4]). The case of a single linear polarization (Fig. 4.1A) allows more general angles for the arm planes (e.g., $\phi_0 = \pm 60^\circ$), provided one accounts for the interaction of the arm pairs [4, 6].

5. Concluding Remarks

The oscillator reflector antenna (ORA) then has various design options. There is a single-ended version using a half reflector with ground plane. There are several differential versions using differential switched oscillators or single-ended switched oscillators with baluns. The differential versions use full reflectors with various polarizations and connections of the switched oscillator (at the focus or at the reflector) to the antenna feed arms.

References

1. C. E. Baum, "A Technique for the Distribution of Signal Inputs to Loops", *Sensor and Simulation Note 23*, July 1966.
2. C. E. Baum, "Variations on the Impulse-Radiating-Antenna Theme", *Sensor and Simulation Note 378*, February 1995.
3. C. E. baum and C. C. Courtney, "Coaxial Beam-Rotating Antenna (COBRA) Concepts", *Sensor and Simulation Note 395*, April 1996.
4. C. E. Baum, "Selection of Angles Between planes of TEM Feed Arms of an IRA", *Sensor and Simulation Note 425*, August 1998.
5. C. C. Courtney, D. Slep, W. Motil, C. E. Baum, R. Torres, and W. D. Prather, "Design and Measurement of a Cassegrain-Type Coaxial Beam-Rotating Antenna", November 1998.
6. J. S. Tyo, "Optimization of the Feed Impedance for an Arbitrary Crossed-Feed-Arm Impulse Radiating Antenna", *Sensor and Simulation Note 438*, November 1999; "Optimization of the TEM Feed Structure for Four-Arm Reflector Impulse Radiating Antenna", *IEEE Trans. Antennas and Propagation*, 2001, pp. 607-614.
7. C. E. Baum, "Antennas for the Switched-Oscillator Source", *Sensor and Simulation Note 455*, March 2001.
8. C. E. Baum, "Switched Oscillators", *Circuit and Electromagnetic System Design Note 45*, September 2000.
9. D. V. Giri, H. lackner, I. D. Smith, D. W. Morton, C. E. Baum, J. R. Marek, W. D. Prather, and D. W. Scholfield, "Design, Fabrication, and Testing of a Paraboloidal Reflector Antenna and Pulser System for Impulse-Like Waveforms", *IEEE Trans. Plasma Science*, 1997, pp. 318-326.
10. W. L. Stutzman and G. A. Thiele, *Antenna Theory and Design*, Wiley, 1981.