

Measurement Notes

Note 59

April 2005

The Response of Commercial Limiters to Transient Signals

Lanney M. Atchley and Everett G. Farr
Farr Research, Inc.

William D. Prather
Air Force Research Laboratory, Directed Energy Directorate

Abstract

In this note we study the response of commercial limiters to transient signals. We do so with the intent of using the limiters as devices to protect oscilloscopes or digitizers in UWB radar systems. Normally, limiters are characterized by their manufacturer only for CW performance, but we are interested here in the response of limiters to transient voltages. We study the limiters' abilities to pass low-level voltages without distortion, and to quickly limit a high-level signal to a maximum value. We also study the input impedance of the limiters while they are turned on, or limiting a signal. We found a surprising variety in the responses of these limiters, and we observed a number of behaviors that are undesirable for the proposed application. We provide recommendations for the best commercially available limiters for the application of UWB radar.

I. Introduction

We characterize here a number of limiters in order to study their response to transient signals. We are particularly interested in how accurately they pass low-level voltages, and how well they clamp the signal at high voltages. Such devices are used to protect the digitizers in UWB radars from overvoltage. Limiters are needed in this application because one must record small signals in the presence of large unwanted signals that are separated in time from the desired signals.

Manufacturers of limiters generally provide response data only for sinusoidal signals. However, for UWB radar, the response to transient signals is of paramount importance. These devices should ideally pass a low-level signal without changing it, and they should immediately clamp a high-level signal to a safe level without allowing a voltage spike to be transmitted. The clamping level should not vary with the voltage of the input signal.

We begin with a description of the intended UWB radar application. We then test the transient response of five commercially available limiters. We also test the TDR of the limiters when they are turned on (limiting), to see if they look like short circuits while they are in that state. Finally, we make recommendations of suitable limiters for UWB radar systems.

II. Typical Configuration

UWB radars generally consist of a pulser, one or more antennas, and a digitizer or oscilloscope. Generally two antennas are used, but one antenna may be used in conjunction with a directional coupler [1]. We describe here the configuration using the directional coupler, although the data on limiters that was collected for this note applies to both configurations.

When a non-ideal directional coupler is used in a UWB radar, it can transmit a large prompt leakage signal that can damage the oscilloscope. An example of a UWB radar system that includes a directional coupler is shown in Figure 1. The relatively high voltage step is passed through the directional coupler from Port 1 to Port 2, then transmitted as an impulse by the transmit/receive antenna. Later, the much smaller scattered signal is received by the antenna and is coupled from Port 2 to Port 4. When the initial step passes through the directional coupler, the voltage at Port 4 is ideally zero. In practice, due to the finite directivity of the coupler, we observe a substantial prompt leakage signal at this port. To protect the sensitive oscilloscope we wish to employ a microwave limiter.

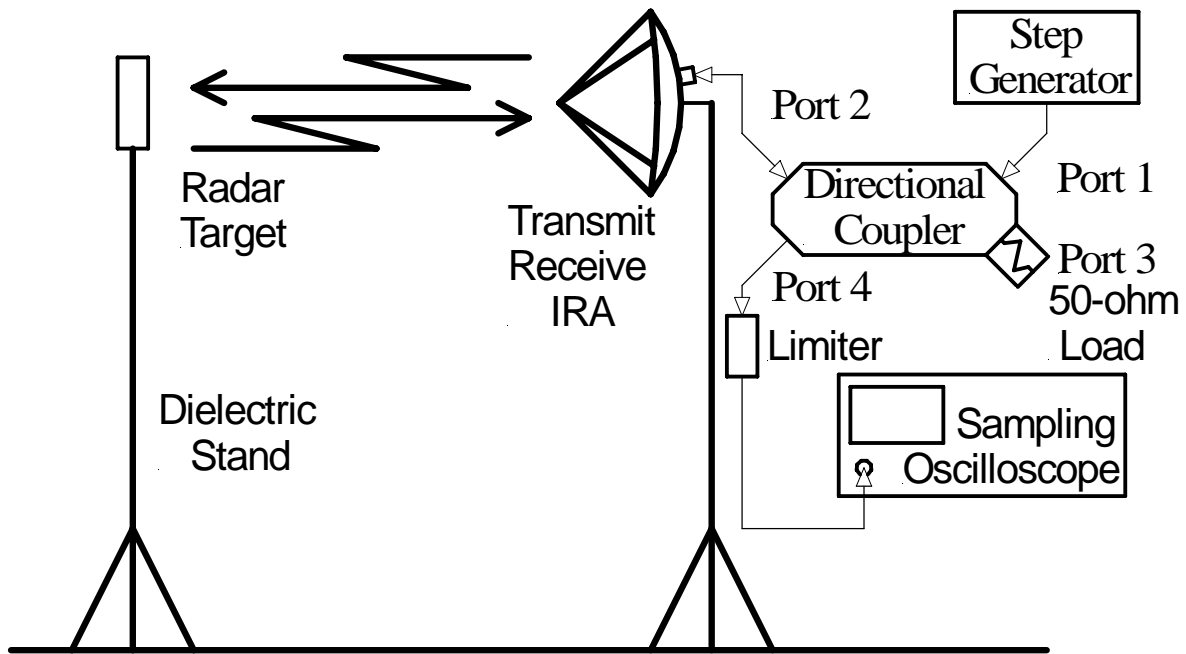

Figure 1. Generic impulse radar instrumentation using a directional coupler.

In general, commercial microwave limiters are specified in terms of CW or peak power, not in terms of transient voltage signals. This led us to investigate the response of limiters to voltage steps of varying magnitude. We have observed a remarkable variety in the response of limiters to step functions, and we document our results here. We have also discovered that some limiters do not function symmetrically, so we have tested both polarities.

We describe here the testing and results for five commercial microwave limiters, and we recommend the device best suited to protect against the prompt leakage signal that is seen in a directional coupler. The results presented here will apply equally well to UWB radar systems using two antennas, because there is a prompt crosstalk between the two antennas.

III. Instrumentation Setup and Test Procedures

To drive our limiters, we used a Kentech model ASG1 pulse generator with a 100 ps rise time at about +230V. To obtain the negative output we inverted the ASG1 with a Grant Applied Physics High Fidelity Inverting Transformer, which slows the risetime somewhat. This inverter consists of a Moebius gap in a semi-rigid cable, with ferrite beads on either side of the gap. We recorded the output on a Tektronix model TDS8000 sampling oscilloscope using a model 80E04 sampling head. The instrumentation setup is shown in Figure 2.

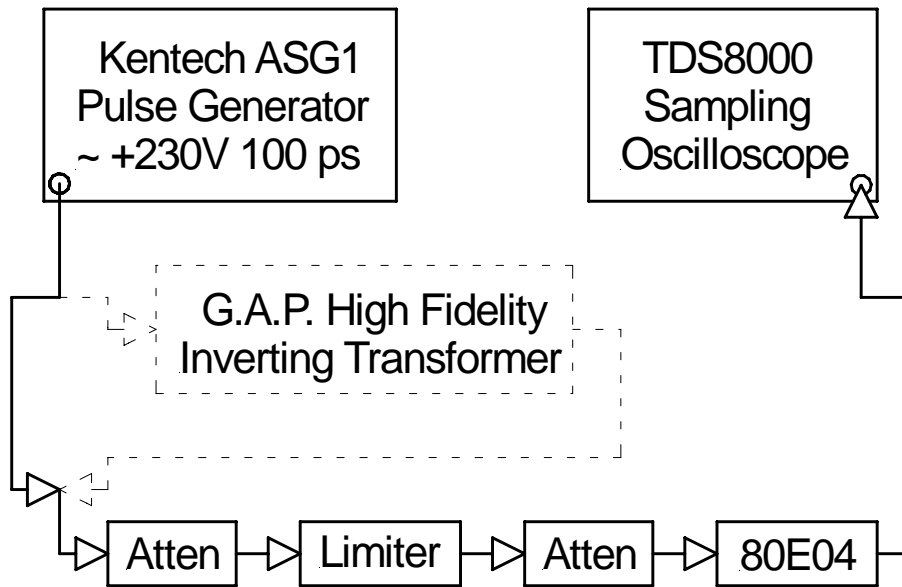

Figure 2. Limiter test setup.

We investigated six RF and microwave limiters. The limiters and their parameters are listed in Table 1.

Table 1. Specifications for Microwave and RF Limiters Tested

Model	Mfg.	Frequency (GHz)	Power		Limits	Comment
			CW (Watts)	Peak (Watts)		
11867A	Agilent	dc – 1.8	10	100	1 mW	
11930B	Agilent	0.005 - 6.0	3	6	1 W	
11693A	Agilent	0.1 – 12.4	1	10	1 mW	
1N50B	Anritsu	0.01 - 3	1.5	?	10 dBm	10 ns turn on
MDC1527P-2-1F	Midisco	0.5 - 18	1	100 (1 μ sec)	?	Dual Pin
MDC1527Y-2-1F	Midisco	0.5 - 18	1	200 (1 μ sec)	6 dBm	Schottky

We drove each limiter at 11 to 12 voltage levels ranging from approximately 50 mV to 23 V in both polarities. We inverted the polarity by inserting the inverter into the test setup. We changed voltage levels by inserting precision attenuators on either side of the limiter as appropriate. The input attenuators varied the drive level to the limiter and the output attenuators protected the sampling head of the oscilloscope from damage.

IV. Limiter Data and Results

A. Agilent Model 11867A Linearity and Limiting Test

We begin by providing the results of the limiting and linearity test of the Agilent model 11867A RF Limiter. In Figure 3 we show the input and output waveforms for the 11867A limiter at eleven voltage levels and two polarities. Positive polarity is in the left column of figures and the negative polarity is in the right column. The traces in the column on the right have been inverted for easy comparison.

Starting at an input of approximately 50 mV, we observe that the output tracks the input to approximately 0.5 V. At these voltage levels, the limiter transmits transient signals with good fidelity. As the input increases in magnitude (in both polarities) above 0.5 V, we see the device's limiting action taking effect. Note that we do not see a *hard* limiting at some specific voltage limit, but rather the output continues to increase somewhat as the voltage increases. This is sometimes described as *soft* limiting in manufacturers' specifications. We also observe a few imperfections in the response to higher voltages, including overshoot in the leading edge, which is sometimes followed by oscillations before settling.

Despite the imperfections described above, the 11867A appears to be relatively well-suited for our application.

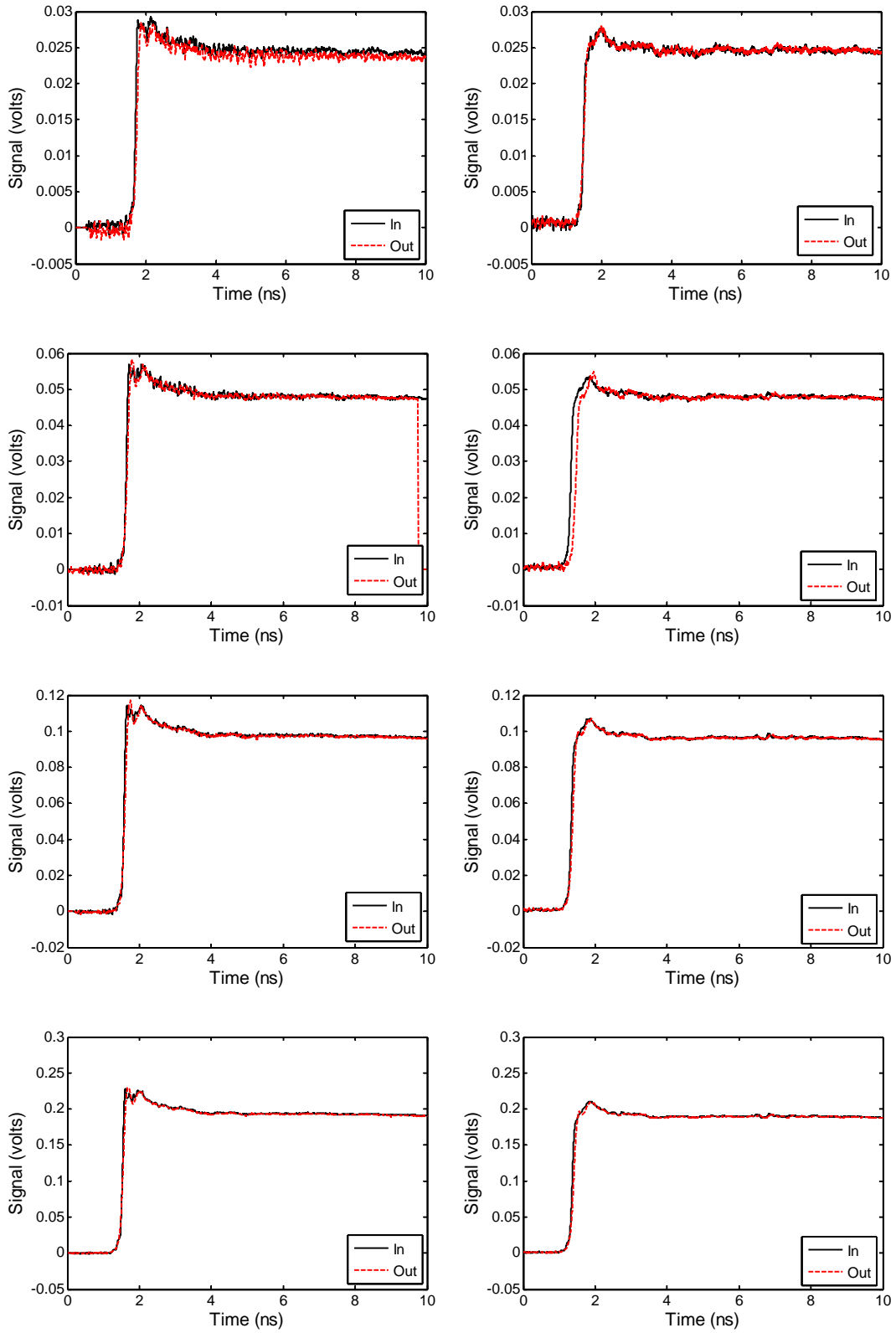

Figure 3. (1 of 3) Inputs and output of the Agilent 11867A limiter at 11 voltage levels and 2 polarities, positive polarity on left, negative on right.

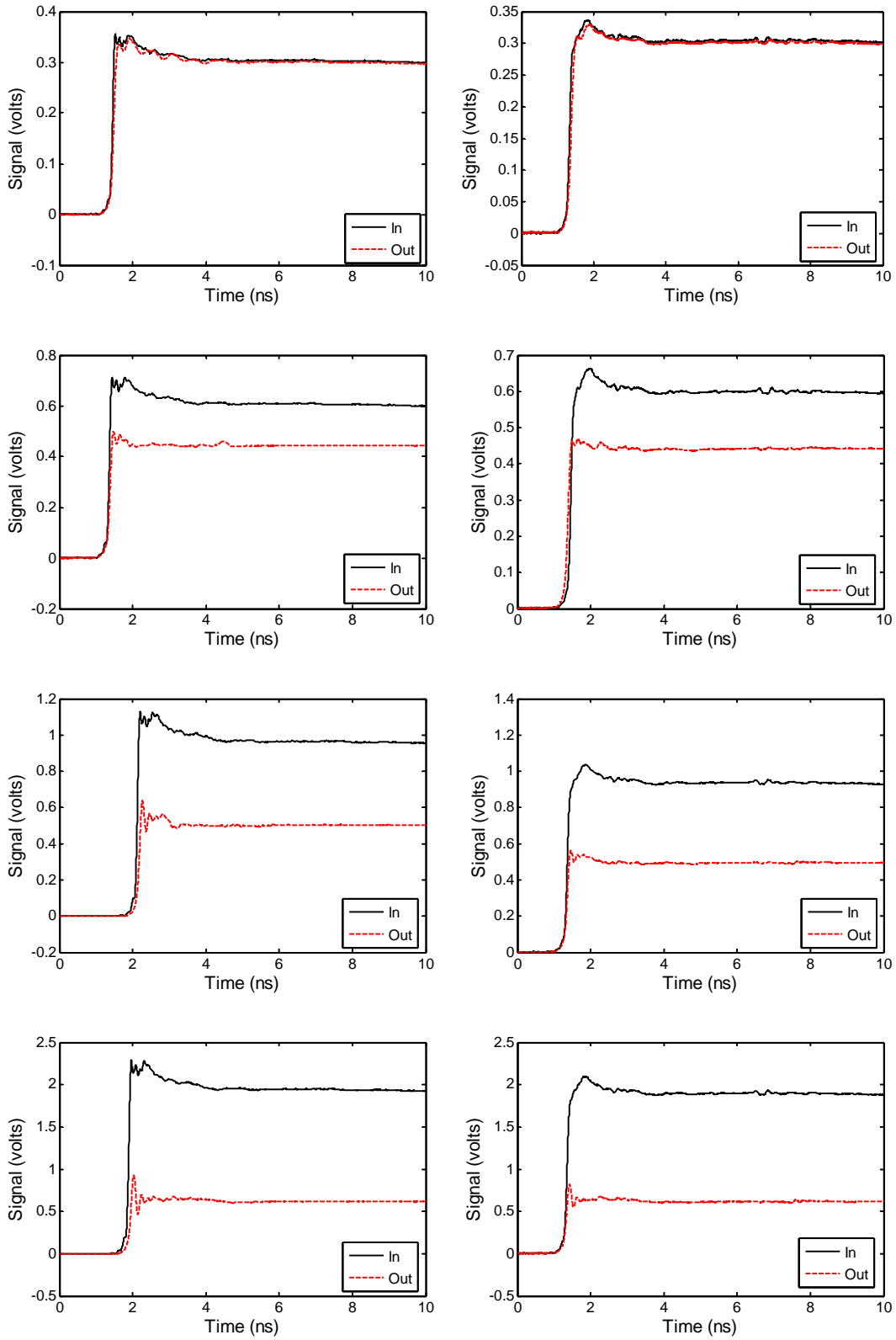

Figure 3. (2 of 3) Inputs and output of the Agilent 11867A limiter at 11 voltage levels and 2 polarities, positive polarity on left, negative on right.

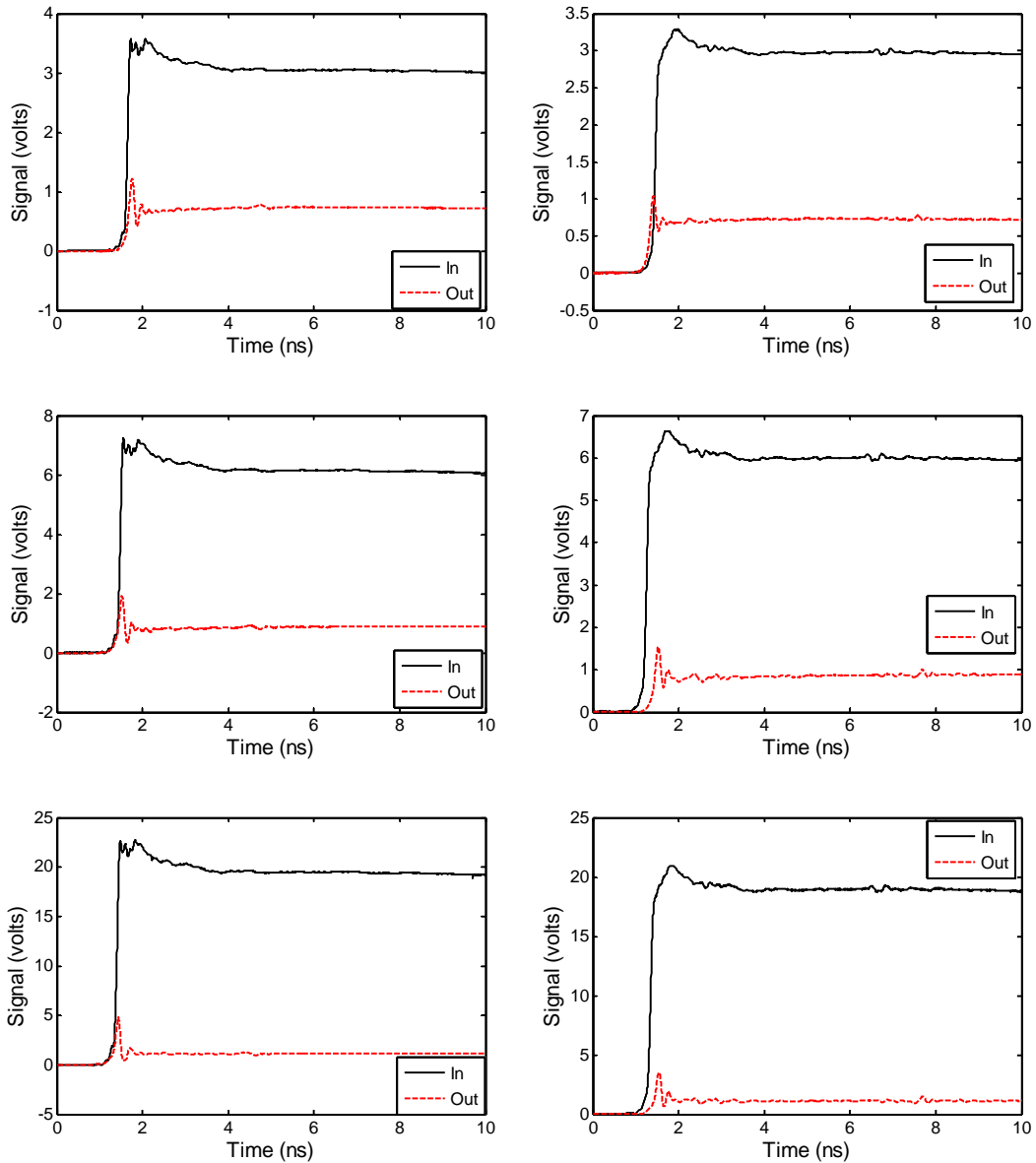

Figure 3. (3 of 3) Inputs and output of the Agilent 11867A limiter at 11 voltage levels and 2 polarities, positive polarity on left, negative on right.

B. Agilent Model 11930B Linearity and Limiting Test

Next, we studied the Agilent model 11930B, and the results are shown in Figure 4. We provide data at twelve voltage levels and two polarities. Positive polarity is in the left column of figures and the negative polarity is in the right column. The traces in the column on the right have been inverted for easy comparison.

From the data, we observe that the limiter action starts at a voltage level of about 5 volts, and soft limits a 20 volt input to 10 volts output. We speculate that the 11930B is DC blocking, which causes a slight downward slope in the output traces. Despite the imperfections, the 11930B appears to be well suited for our application.

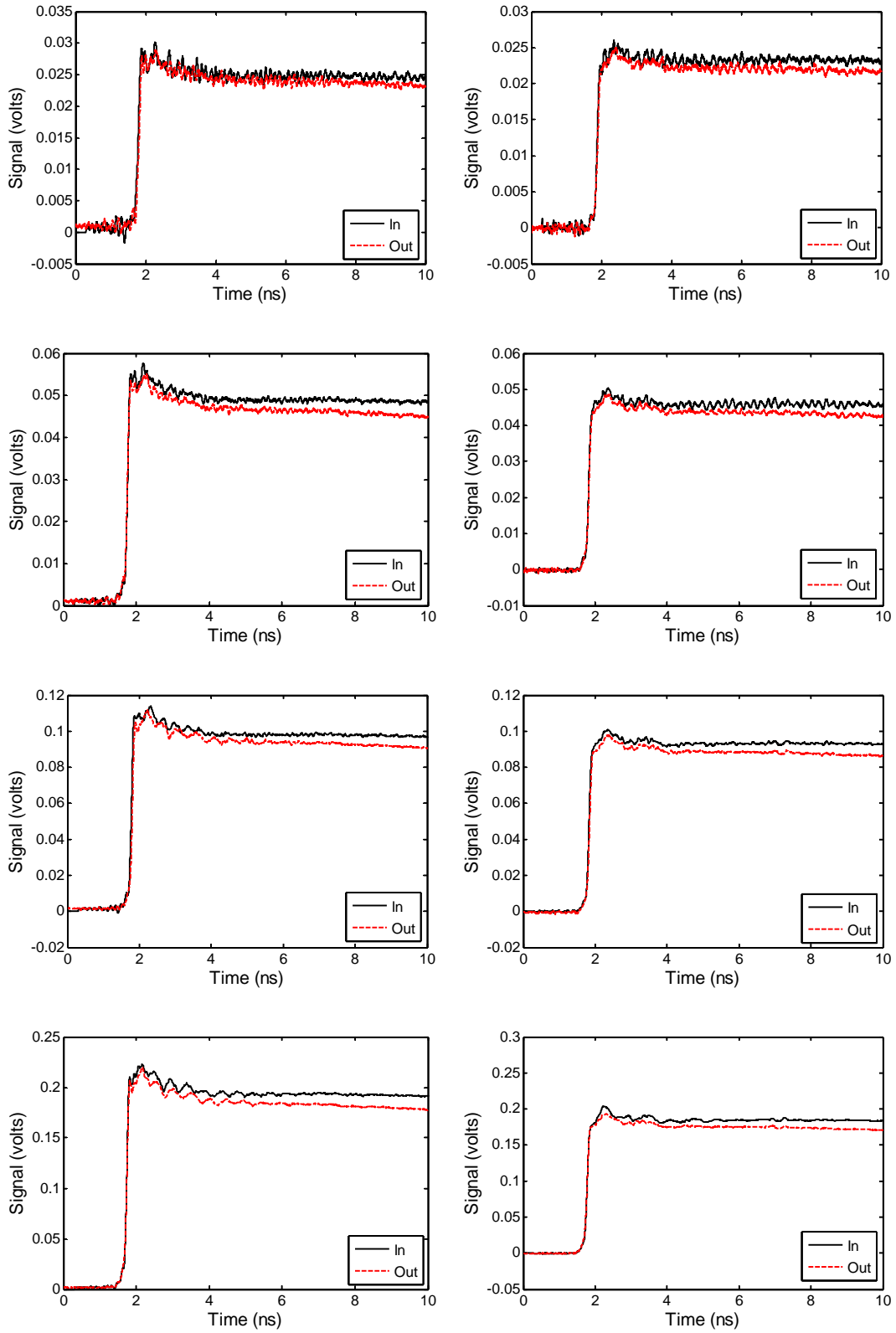

Figure 4. (1 of 3) Inputs and output of the Agilent 11930B limiter at 12voltage levels and 2 polarities, positive polarity on left, negative on right.

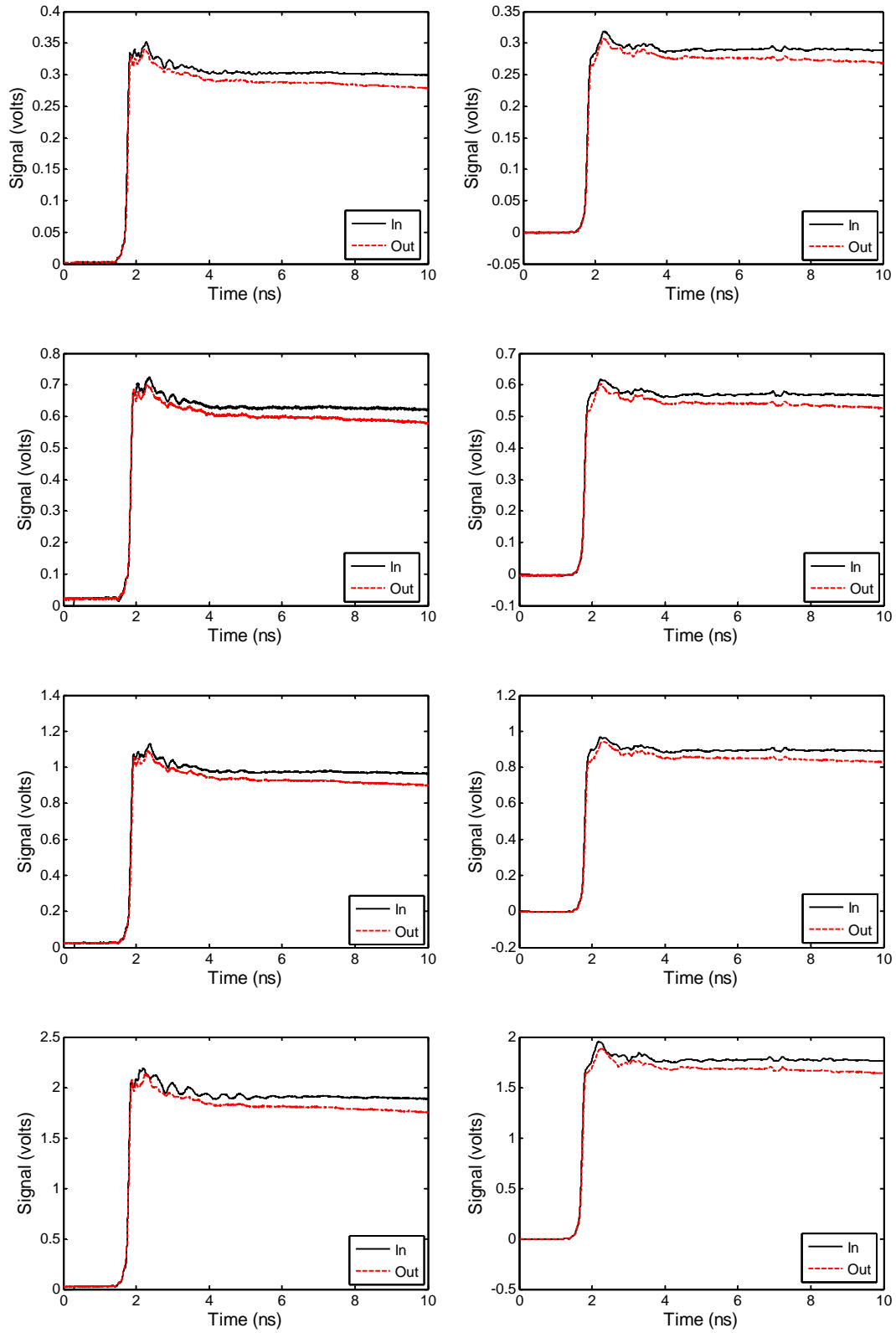

Figure 4. (2 of 3) Inputs and output of the Agilent 11930B limiter at 12voltage levels and 2 polarities, positive polarity on left, negative on right.

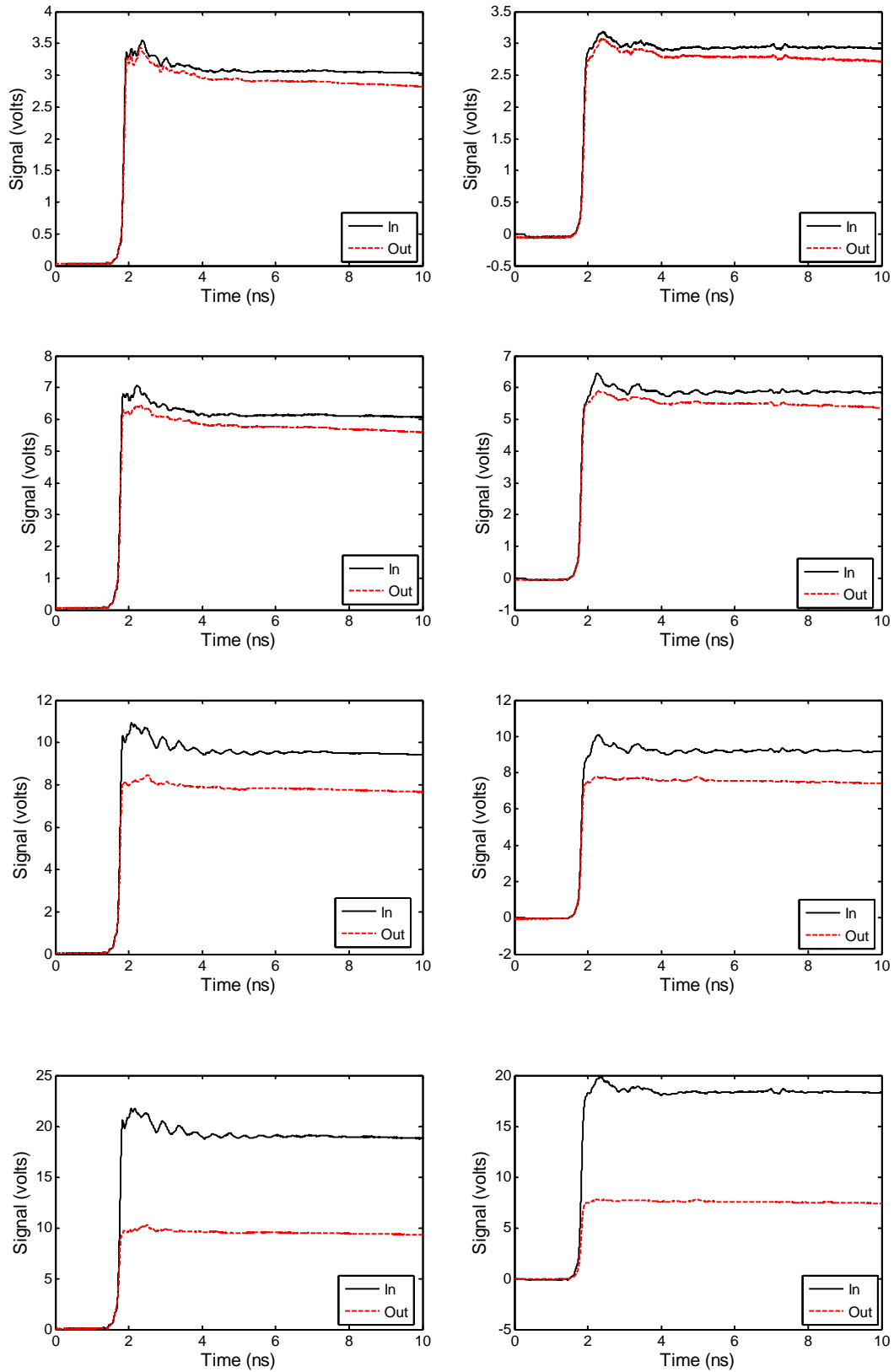

Figure 4. (1 of 3) Inputs and output of the Agilent 11930B limiter at 12 voltage levels and 2 polarities, positive polarity on left, negative on right.

C. Agilent Model 11693A Linearity and Limiting Test

Next, we investigated the Agilent model 11693A limiter. Because of a very long delivery time (18-weeks) for this device, it is probably not suitable for our use. Nevertheless, we compile here the information we have on it.

During the course of testing, we observed a large insertion loss, indicating that the device had failed. Before that failure, however, we observed that the device had a strong dependency on the input polarity. We found that limiting only occurred for transient signals of positive polarity. Negatively polarized signals passed without limiting. This was later confirmed by John Aurand and Gary DeMuth [2], who reported a similar result.

To confirm the polarity dependence of the 11693A limiter, we obtained its schematic diagram from Agilent, as shown in Figure 5. Based on this schematic, we would not expect it to operate the same for both polarities. This, coupled with the long delivery time, suggests that the 11693A will not be useful for our application.

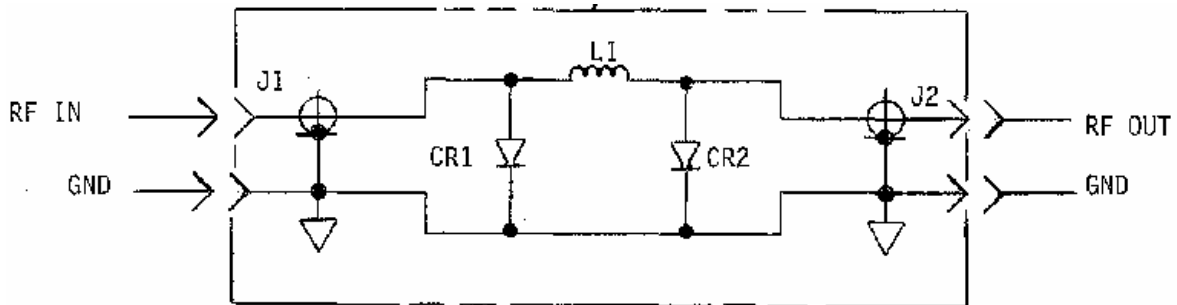

Figure 5. Schematic diagram of the Agilent 11693A limiter.

D. Anritsu Model 1N50B Linearity and Limiting Test

Next, we tested the Anritsu model 1N50B limiter, and we provide the results in Figures 6 and 7. Here, we overlay several voltage levels of input and the corresponding output. In Figure 6 we show the results for positive inputs, and in Figure 7 we show the results for negative input. We observe that the 1N50B is quite linear below about 1 V. However, at higher voltages the limiter transmits a high-voltage spike before settling down and limiting the signal. Since this spike may damage the oscilloscope, the Anritsu 1N50B is probably not well suited to our application.

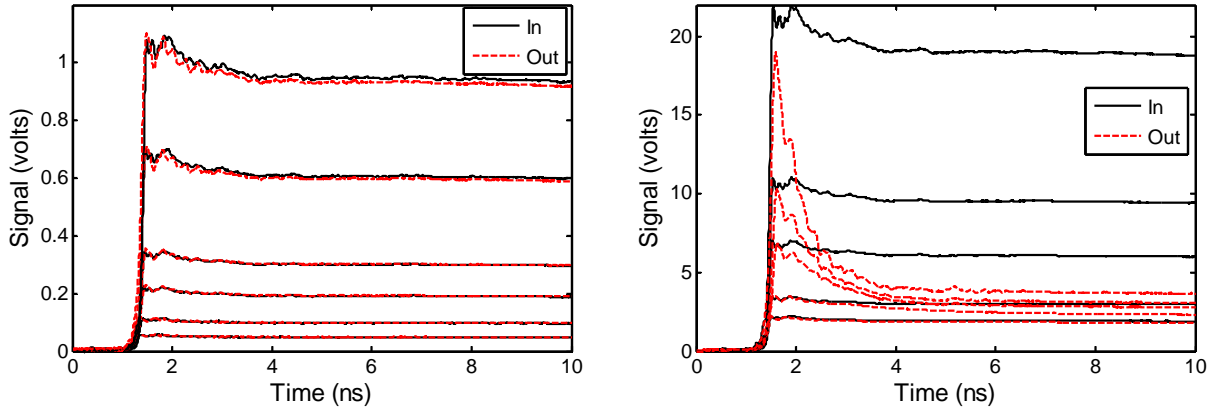

Figure 6. Anritsu 1N50B limiter, positive input.

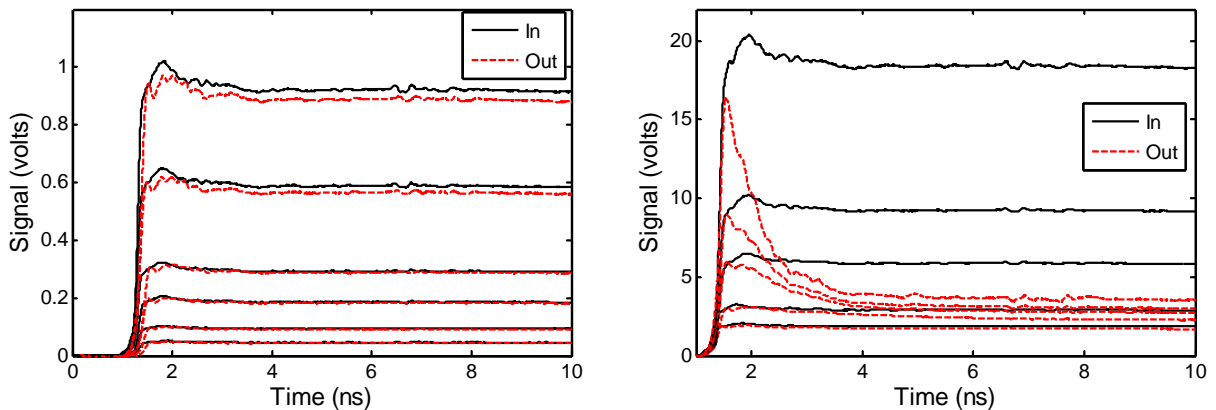

Figure 7. Anritsu 1N50B limiter, negative input, inverted.

E. Midisco Model MDC1527P-2 1F Linearity and Limiting Test

Next, we tested two less expensive limiters: the Midisco models MDC1527P-2 1F and MDC1527Y-2 1F. The results for the MDC1527P-2 1F are shown in Figures 8 and 9. We observe that the limiter does not track the input signal at low voltages. In addition, it behaves differently for the two polarities, and it does not adequately limit the negative input. So this limiter is not suitable for our application.

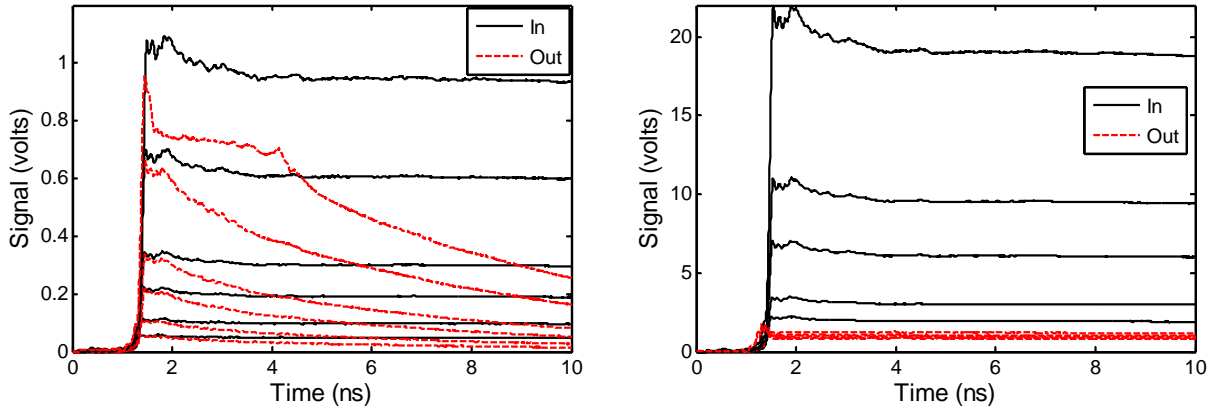

Figure 8. Midisco model MDC1527P-2 1F limiter, positive input.

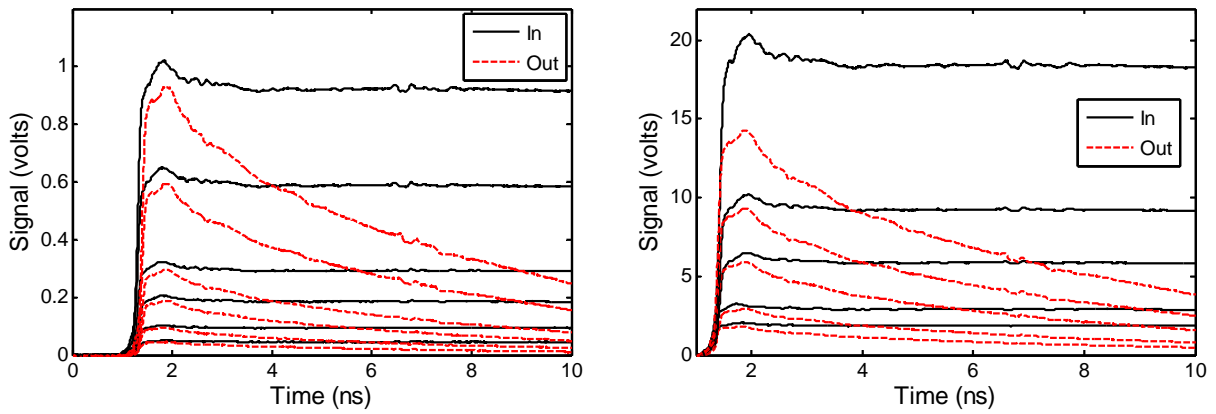

Figure 9. Midisco model MDC1527P-2 1F limiter, inverted.

F. Midisco MDC1527Y-2 1F Linearity and Limiting Test

Finally, we tested the MDC1527Y-2 1F limiter, and the results are shown in Figures 10 and 11. In a manner similar to the other Midisco limiter, this device does not track the low-voltage signals well, and it does not limit the negative polarities. So it is not suitable for our application.

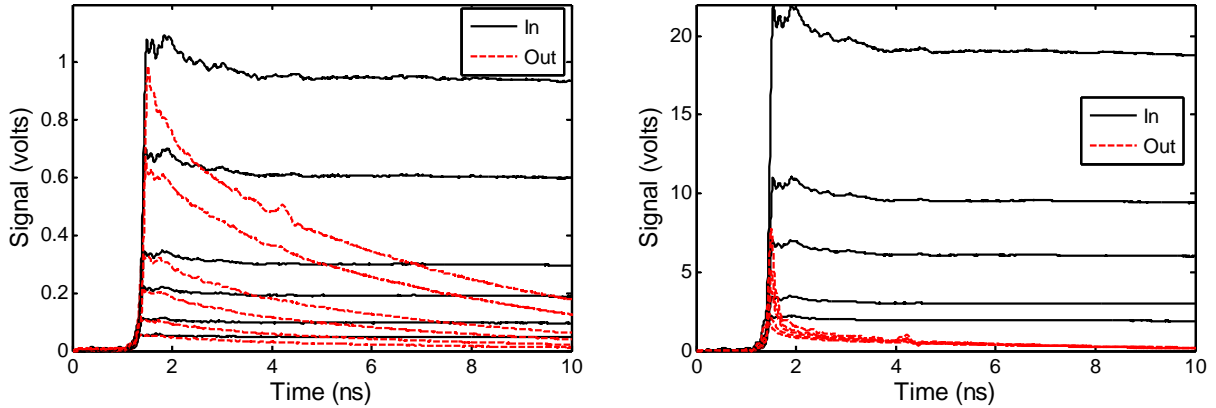

Figure 10. Midisco MDC1527Y-2 1F limiter, positive input.

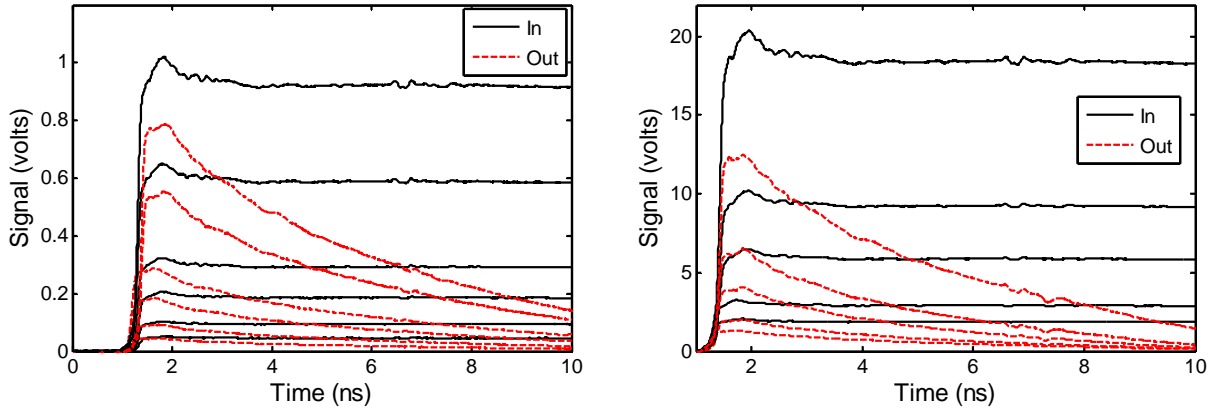

Figure 11. Midisco MDC1527Y-2 1F limiter, inverted.

V. Limiter Input Impedance.

Next, we measured the input impedance of these limiters while they are turned on and limiting an input signal. We did this because there was some speculation that the limiters would look like short circuits when turned on, which could add spurious reflections to our radar signal, and we wanted to test that theory. We therefore measured the TDRs of our limiters while in conduction, using a Picosecond Pulse Labs model 4015C step generator and a Tektronix model TDS6804B sampling oscilloscope.

A sketch of the TDR configuration is shown in Figure 12. This configuration is somewhat elaborate because we had to drive the limiter with a large enough voltage (2.5 V) to drive the limiting diode into conduction. Furthermore, we wanted to drive some, but not all, of the limiters into conduction. The TDR is constructed by simply passing the output of the step generator by the oscilloscope input through an SMA tee. The limiter under test is connected to the third leg of the tee.

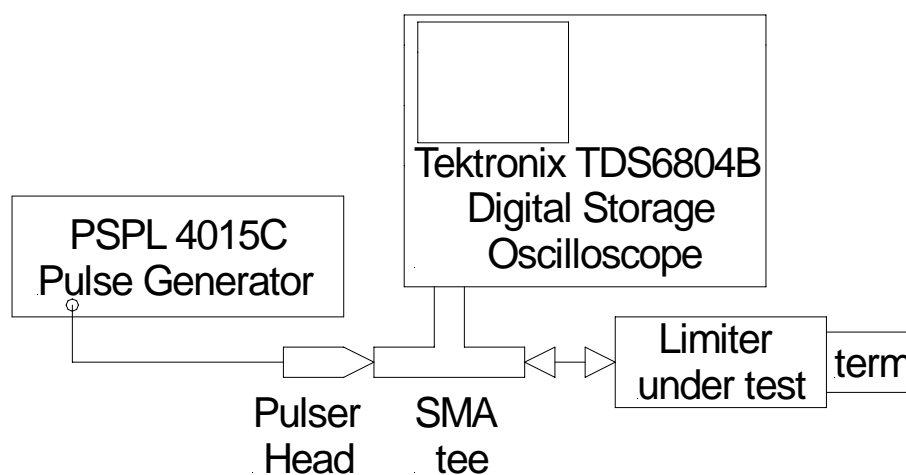

Figure 12. TDR instrumentation.

To calibrate the system, we measured the TDR of an open line, a matched line, and a shorted line, and the results are shown in Figure 13. Because we do not have matched impedances at the tee, the waveforms look a bit different from those observed in a conventional TDR setup. But this configuration serves our purposes, because it allows us to determine the gross input impedance of a limiter when it is driven with 2.5 volts, which is enough to drive a limiter into conduction.

In Figure 14 we show the results of carrying out the TDR with four limiters: the Agilent models 11693A and 11867A, an Anritsu model 1N50B, and a Midisco model MDC1527Y-2 1F. As the figure shows, the two Agilent limiters reflect out-of-phase and look very similar to the shorted termination. The diodes of the two Agilent limiters are in conduction and the limiters would provide protection at this 2.5 V level. The Anritsu and Midisco limiters most closely approximate a terminated line. Their diodes are not conducting and the input signal would pass through the diode either unaffected or only slightly distorted.

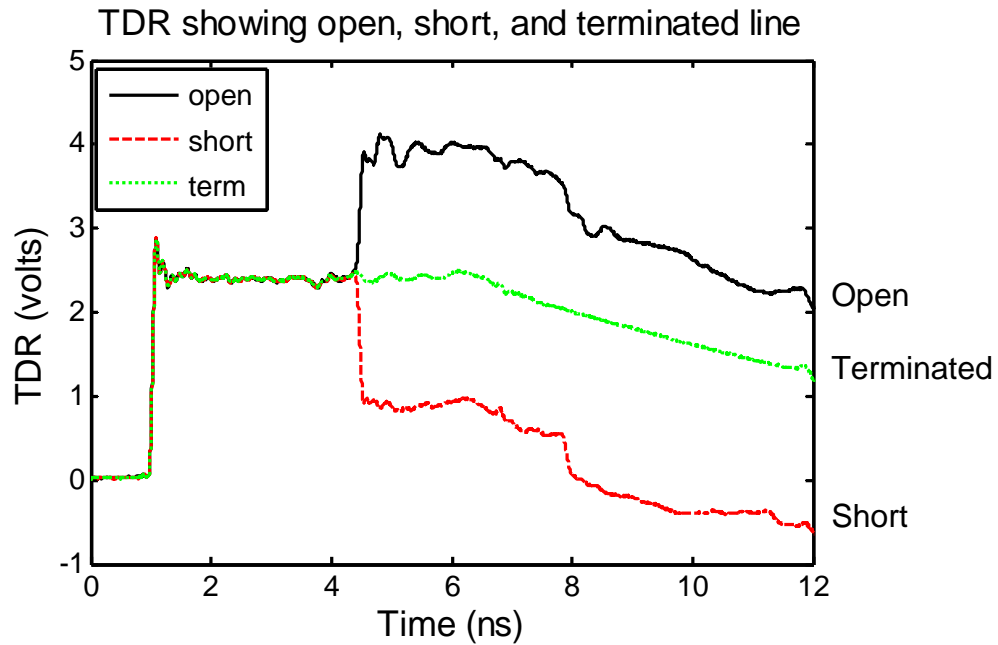

Figure 13. TDR of open, matched and shorted 50-ohm line.

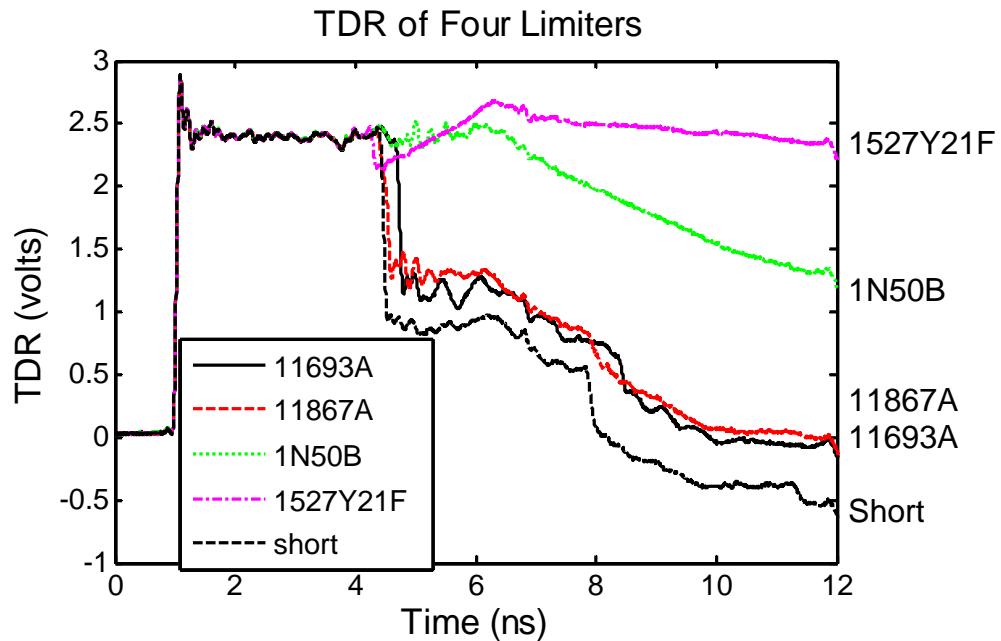

Figure 14. TDR of Four Limiters

The TDR results show that when the limiter diode is turned on and in conduction mode, the input will appear as a short circuit. This creates an unmatched termination at the directional coupler, which can lead to increased internal reflections. Since the limiter should be conducting only during times of large internal reflections, when no radar returns of interest are present, the problem may not be important. These reflections will fall outside the time window of the data of interest. But a condition may exist that increases the size of the internal reflections to a level that causes concern. This may happen if the multiple internal reflections are radiated through the antenna and thereby contaminate the scattered signal.

VI. Discussion

Of the six limiters we examined, the Agilent models 11867A and 11930B were the best suited to our application. The main difference between the two is the 11867A started limiting at around 0.5 V, while the 11930B started limiting at around 8 V. In addition the 11867A can tolerate a much higher power than the 11930B, as shown in Table 1. These devices are not ideal, however, because they both exhibit soft limiting, and the 11867A exhibited some overshoot in its step response. In addition, the 11930B exhibited a small amount of droop in the step response at late time.

The Agilent model 11693A limits only the positive polarity, so it would be difficult to use in our application.

The Anritsu model 1N50B allows a large voltage spike to pass through it, and it requires about 2 ns to settle down to the steady-state limited voltage. It is unclear at this point whether this settling time is short enough to avoid damaging the oscilloscope, but conservative design would tend to argue against using it without further data.

The two Midisco limiters had poor fidelity at low voltages and long settling times at high voltages, so they were judged to be not suitable.

As a result of the TDR testing, we observed that the limiters look like short circuits when they are in limiting mode. This may cause spurious reflections that could contaminate the data, so the design of the radar system must take this into account.

We note that we do not yet have good data on what level voltage can be tolerated by a digitizer or oscilloscope before causing upset or damage. Manufacturers generally specify that the peak-to-peak applied voltage should not exceed the full-screen voltage range of their scope multiplied by some factor – typically three. However, oscilloscope manufacturers typically do not test such claims, and may be forgiven for being conservative. Furthermore, it seems reasonable that oscilloscopes should be able to tolerate a higher voltage spike if its duration is shorter. But there has been no time dependence incorporated into their guidelines.

To resolve the problem with testing oscilloscope tolerance to HV pulses, we can imagine two scenarios. First, we might test the digitizers and oscilloscopes to failure, but this would be prohibitively expensive. A more reasonable approach would be to insert a buffer amplifier between the limiter and pulser, and test the amplifier to failure. Since amplifiers are nonlinear devices, we would have to characterize their transient responses in precisely the same way that we have done so with limiters in this paper.

VII. Conclusion

Two of the limiters tested here were best suited for our application of UWB radar, the Agilent models 11867A and 11930B. However, neither of these were ideal. Both of these exhibited soft limiting rather than hard limiting, so the clamping voltage is higher when driven by a higher input. The 11867A exhibited a small voltage spike in the transmitted voltage. The 11930B exhibited a small amount of droop in the step response at late time.

The other limiters were either less suitable or unsuitable for our application for a variety of reasons. These include limiting for only one of the two polarities, or limiting that turned on too late to protect the digitizer. We also observed transmission of large voltage spikes at the leading edge.

We also observed that the limiter looks like a short circuit when it is turned on, which may cause spurious reflections in the data.

As a result of this research, we can suggest additional areas of investigation. First, it would be useful to investigate the possibility of building a custom limiter design that addressed the non-ideal characteristics cited above. Second, it would be useful to have a better understanding of the peak voltages and voltage durations that can be tolerated by oscilloscopes and digitizers. Since it would be prohibitively expensive to test oscilloscopes to failure, we should investigate the use of buffer amplifiers to be inserted between the limiter and oscilloscope. Buffer amplifiers can be tested to failure, but it will be necessary to characterize their response to transient signals in precisely the same way we have done here with limiters.

Acknowledgement

We are pleased to acknowledge the advice and support of Dr. John Aurand and Mr. Gary DeMuth of ITT Industries, who shared with us their data on this subject. We also wish to thank the Air Force Research Laboratory, Directed Energy Directorate, for funding this work.

References

1. L. M. Atchley, E. G. Farr, D. E. Ellibee, and D. I. Lawry, A High-Voltage UWB Coupled-Line Directional Coupler, Sensor and Simulation Note 489, April 2004.
2. John Aurand and Gary DeMuth, ITT Industries, personal communication.