

Measurement Notes

Note 44

August 1993

**QUAD COAXIAL BALUN (QCB)**

**Gary D. Sower**  
**EG&G Special Projects**

**Donald P. McLemore**  
**Kaman Sciences Corporation**

**William D. Prather**  
**Phillips Laboratory**

**ABSTRACT**

Various types of electromagnetic field simulators exist for testing of systems using low-level swept continuous-wave radio frequency signals. Many of these are sparse antennas consisting of a very few conductive wires. The driving-point impedance is thus generally large, typically a few hundred ohms; it is also frequency dependant and complex, possessing both reactive and resistive parts. The broad-band power amplifiers used to drive these antennas are designed for other applications and are matched to lower impedance loads, usually 50 ohms, which is also the impedance of the cable from the amplifier to the antenna. For a maximum power transfer into the antenna, the source and load impedances must be matched; the greater the mismatch, the less power is transmitted.

An impedance conversion transformer which utilizes transmission lines, known as a balun, is used to increase the drive impedance to the antenna. For the particular family of baluns described, the impedance is quadrupled to 200 ohms. This is not a perfect impedance match across the frequency bands of interest because of the variation of antenna impedance with frequency, but is a significant improvement from the 50 ohm amplifier output.

The baluns described provide a flat bandwidth (within the half-power points) over a very broad bandwidth of about five decades. The upper frequency limit is several hundred megahertz. They are capable of driving large signals of a few hundred watts onto the antenna. They are also small and light in weight compared to some other balun designs. Both differential-mode and common-mode signals can be driven onto the antennas, depending upon on the balun-to-antenna connections; a single balun can be used to drive both modes.

## I. INTRODUCTION

This report describes the development and prototype testing of a power driver balun for the ELLIPTICUS antenna for low-frequency CW illumination testing. Tests of the first prototype showed that the frequency range achieved is far greater than original expectations, about five decades, and that this device would be suitable for use in other simulators such as ACHILLES III.

The large bandwidth is obtained by a careful RF design of the transmission line connections and by using ferrite beads with different properties to choke unwanted currents over different frequency ranges. The linear design of this balun allows for the use of the different ferrites, as well as producing small diameter conductors to give a reasonably good impedance match to the antenna cables of ELLIPTICUS.

The Quad Coaxial Balun (QCB) designation is a natural extension of the Twin Coaxial Balun (TCB), described in PL Measurement Note 34, 3 June 1987, because it utilizes four coaxial output cables instead of two. This design alleviates the power-handling problem inherent in the TCB.

## II. BALUN THEORY

The term **balun** is an acronym for **balanced-to-unbalanced**, as applied to a type of transformer for matching a balanced signal line to an unbalanced line. It is a transmission line transformer which differs from the conventional transformer in which energy is transmitted from the input to the output by magnetic flux linkage. In the balun, the energy is transmitted by transmission lines as a differential-mode signal on each line, with common-mode propagation being prevented (ideally) by the choking action of magnetic materials.

The use of the term **balun** is slightly misused here, because the QCB is designed to convert an unbalanced line (50 ohm coax) to a balanced line (200 ohm balanced line). However, reciprocity of the physics involved allows for the usage.

Coaxial Cable: The theory of a balun constructed from coaxial cable must start with the coaxial transmission line. **Figure 1** is the coaxial line, with a solid wire for the center conductor and a solid tube for the outer conductor, with an insulating dielectric between them.

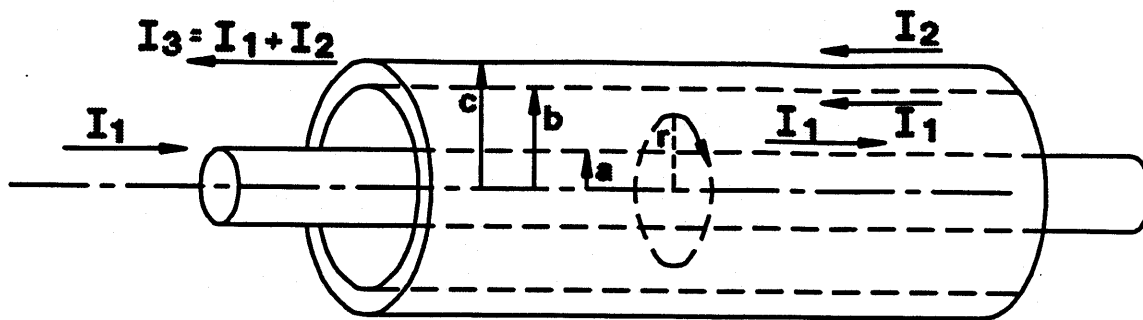

Figure 1. Coaxial Cable.

A wire (the center conductor) carrying a current  $I$  generates a magnetic field:

$$H_{\phi} = \frac{I}{2\pi r} \text{ amperes/meter.} \quad (1)$$

Consider a coaxial line carrying current  $I$  on the inner conductor and  $-I$  on the outer (the return current): Outside the outer conductor, a circular path encloses both the going and return current, or a net current of zero; hence there is no exterior magnetic field. Conversely, if the exterior magnetic field is constrained to be zero, then the only current on the outer conductor must be the return current.

At high frequencies where the wall thickness of the outer conductor is much greater than the skin depth of the wave in it (100 kHz for .010" copper), the return current flows only along its inner surface. The boundary conditions of the TEM wave within the coax dictate that the flux is perfectly coupled between the two conductors, which is exactly the same requirement for an ideal transformer. The coupling is then modeled as an ideal transformer so that identically equal and opposite currents exist on the signal conductors.

The current on the outside of the outer conductor is not constrained by the coaxial cable properties, but is governed by the impedances, both deliberate and stray, to which the outer conductor is connected. Figure 2 is a model of the coaxial cable and its currents. It may be considered to consist of three separate conductors as shown. This concept is essential to the ensuing analysis.

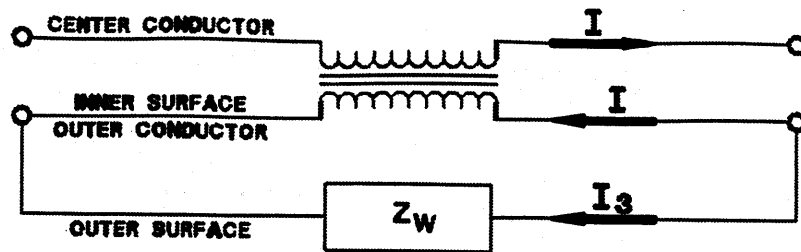

Figure 2. Model of Coaxial Cable, with Back Impedance.

The impedance of the jacket exterior to the outside world  $Z_w$  is known as the cable **back impedance**, and is typically about 100 ohms to 300 ohms, depending upon the geometry. It is present for any coaxial cable whenever the jacket is not circumferentially bonded to another coaxial conductor. This impedance is in parallel with the coax characteristic impedance, reducing the circuit impedance, and results in unwanted currents flowing on the jacket exterior. These currents can be greatly reduced with ferrite chokes placed over the assembly, adding their series impedance  $Z_f$  to the back impedance, giving a total impedance  $Z_B = Z_w + Z_f$  as in Figure 3.

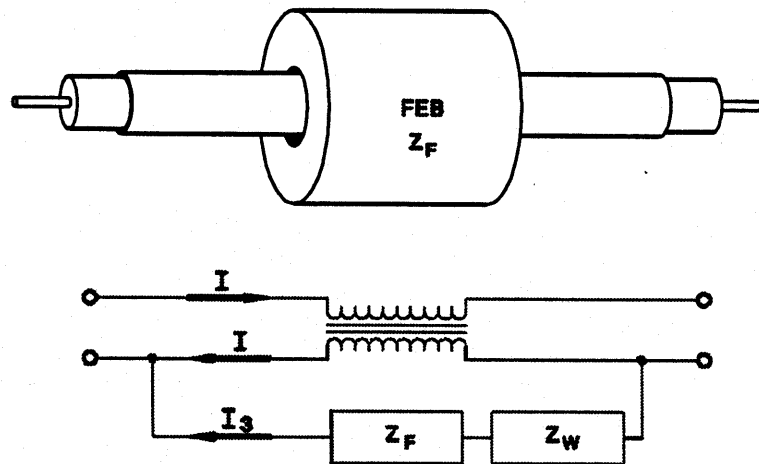

Figure 3. Coaxial Cable Loaded with Ferrite Beads to Reduce Back Impedance Currents.

A sufficiently high impedance from the ferrite beads (infinite) reduces the total current through them to zero, so that the equal and opposite differential signal is unperturbed and the exterior shield current is eliminated. This statement applies at high frequencies where the unwanted exterior current would be limited to a skin depth, and also to low frequencies where the return current fills the entire wall of the outer conductor.

**TCB Limitations:** The TCB is constructed with 100 ohm semi-rigid (solid copper jacket) coax. Two of these cables are connected in

parallel to the 50 ohm input and wound on a large magnetic core (the choke) to give symmetrical 100 ohm outputs in serial (push-pull) for the 200 ohm balanced output. The principal problem with the TCB is that these 100 ohm coaxial cables fail when an appreciable power is transmitted through them, because of the very fine wire required for the center conductor. The wire is only .0069 inch in diameter, and is made of steel with a silver plated copper sheath. It will transmit only about 30 Watt at 100 kHz; at higher power levels or higher frequencies the wire becomes so hot that the teflon dielectric swells and ruptures the jacket. With a drive level of 100 Watt into the TCB, 50 Watts is put into each 100 ohm coax. They could handle this power for a short time, such as used for a network analyzer sweep, but if the power was left on for a longer time, the failures occurred.

A Novel 100 ohm Transmission Line:

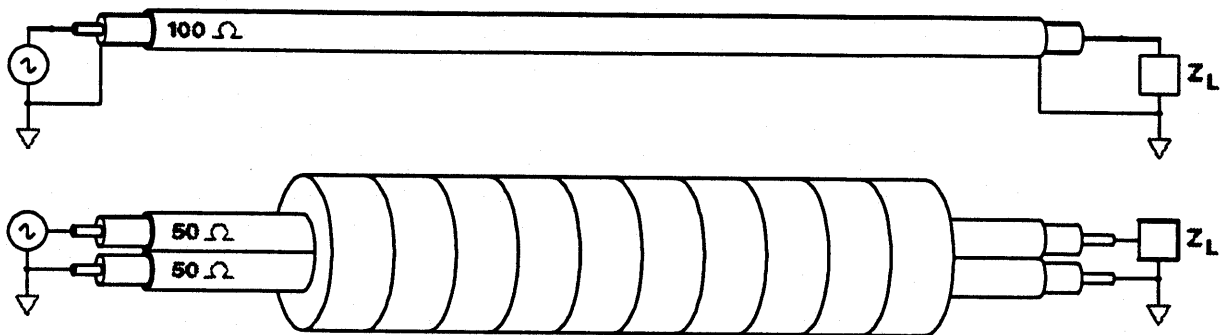

**Figure 4. 100 ohm Transmission Line Formed from Two 50 ohm Lines.**

One of the authors (McLemore) suggested that the 100 ohm coax be replaced with a pair of 50 ohm coaxial lines, which can carry 500 Watts at 100 kHz (200 Watts for a short time at 1 GHz), physically oriented in parallel but electrically connected so that they form a single 100 ohm line, as seen in Figure 4. The outer conductors (jackets) of the cables are connected to each other for their length, but not to any other conductor. They are seen to lay along the symmetry plane of the geometry, which may be made to be the zero-potential plane if equal and opposite potentials are impressed on the two center conductors. The differential impedance of this arrangement is then twice that of each cable, or 100 ohms. The two cables may be considered to be wired so that their characteristic impedances are in series.

Within each coaxial cable, the going current and the return current are identically equal and opposite. Equal and opposite current also flows on the two center conductors when driven in differential mode. These two conditions then require that the two return currents be equal and opposite; they merely pass around the ends of the cables, from the interior of one coax to the interior of the other.

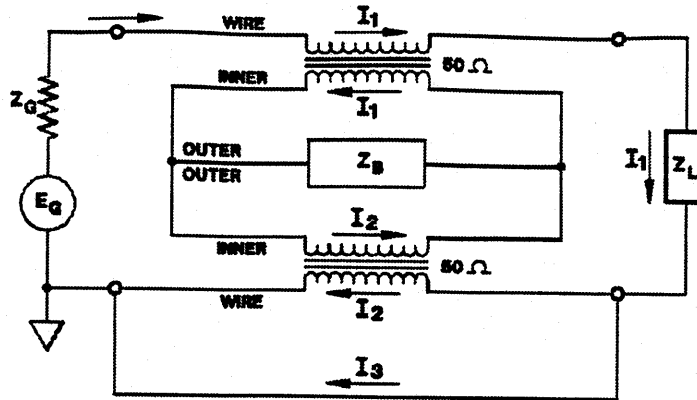

**Figure 5. Equivalent Circuit of Two 50 ohm coaxial Cables Connected as a 100 ohm Coax.**

An equivalent circuit can be developed for the above circuit, as shown in Figure 5. The assumed perfect coupling within each coaxial cable is represented by an ideal transformer as in Figure 3 above. The loaded back impedance  $Z_B$  now is in series with the outside of the two outer conductors which are shorted together. Analysis of this circuit shows that  $I_B = I_3$ ; the current through the loaded back impedance is equal to the ground return current. The circuit performance is identical to that of a circuit with  $Z_B$  moved from the center loop to the ground return line. The center loop is then unnecessary and can be removed. The result is then the equivalent circuit of Figure 3, that of the single 100 ohm coax. The two 50 ohm cables thus act as a single 100 ohm transmission line, at least for the electrically short case.

**This configuration is topologically equivalent to a 100 ohm twin-axial transmission line, with a conductor inserted across the zero-potential symmetry plane.**

For frequencies where appreciable phase differences occur within the length of the coax, the unwanted currents are not zero but become small as  $Z_B$  becomes large with the use of ferrite bead loading. The comprehensive theory in this case has not yet been developed. Resonances will occur at frequencies corresponding to  $1/2$  or  $1/4$  wavelength in the coax, but these will be small and not preclude the use of the QCB.

**1:4 Driver Balun:** The particular balun configuration that is discussed here is the 1:4, where the output impedance is four times the input impedance ( $50\Omega:200\Omega$ ). One way to think of it is a pair of 100 ohm transmission lines connected in parallel at the balun input and in series at the output. This can be done because of the large impedances introduced into the circuit by the chokes. Figure 6 is the circuit of the balun, with the 100 ohm line either a 100 ohm coax or a pair of 50 ohm coax as in Figure 4.

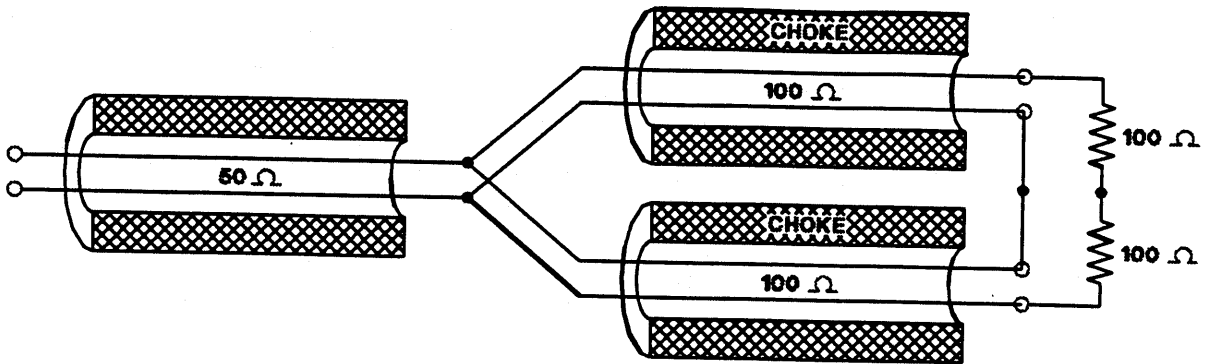

Figure 6. The 50Ω - to - 200Ω Balun.

Ideally, the output of each 100 ohm line is terminated in its characteristic impedance, namely 100 ohms, as shown. The equivalent circuit of this balun, using the results derived above, is shown in Figure 7. The performance of this balun is significantly dependant upon whether or not the output is grounded, and where it is grounded (the input must be grounded, being single-ended).

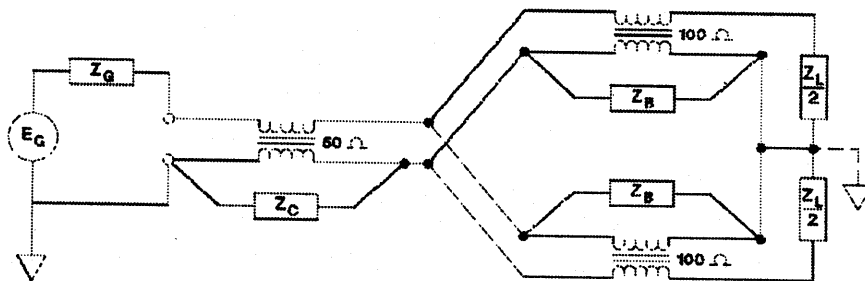

Figure 7. Equivalent Circuit of 1:4 Balun.

With the output floating, the choke on the input line is not needed. The two output lines can use separate chokes as shown, or they can be wound on a single choke core.

If the output is grounded at the center tap of the load, significant low-frequency degradation occurs, especially if both output lines are wound on a single core. Adding a 1:1 balun in series with the input (the choke on the 50 ohm line) restores the low-frequency performance; it is not required with two separate chokes on the outputs.

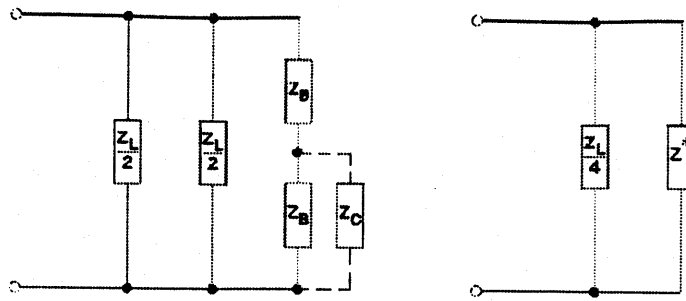

Figure 8. Input Impedance of 1:4 Balun.

The input impedance of the balun is given in Figure 8, with the grounded configuration dashed. The value of this impedance is given by:

$$Z_{in} = \frac{Z_L Z^*}{Z_L + 2Z^*} \quad (2)$$

where the back-impedance factor  $Z^*$  for the floating output is:

$$Z^* = 2Z_B \quad (3)$$

and for the grounded center tap is:

$$Z^* = Z_B + \frac{Z_B Z_C}{Z_B + Z_C} \quad (4)$$

$Z^*$  is in parallel with the load impedance combination, and diverts some of the input signal from the load. This explains why baluns always have more loss than given by the ideal equation.

#### Unbalanced Loading of 1:4 Balun

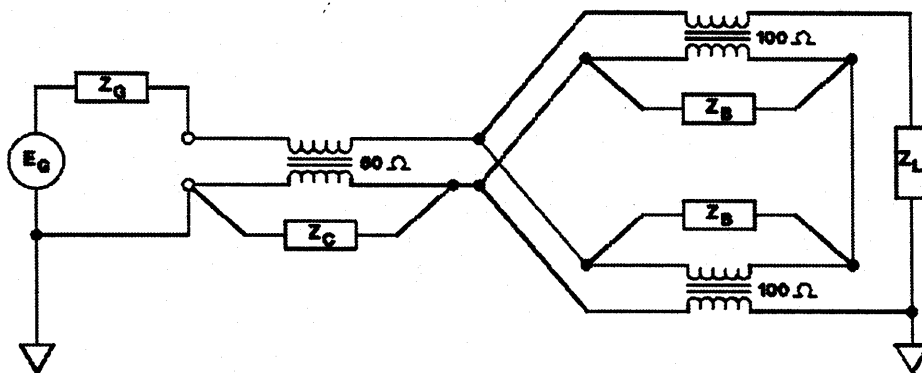

Figure 9. Equivalent Circuit of Asymmetric Loaded Balun.



For the ELLIPTICUS antenna there are only two output conductors, so two of the three QCB output lines must be connected together. This results in an asymmetric loading of the balun output which degrades the balun output. However, it is still very acceptable for use in ELLIPTICUS. Figure 9 is the equivalent circuit of the balun with the unbalanced loading. The zero-potential connection along the previous symmetry plane, between the common output point and the load center tap, is no longer present because there is no center tap point on the output.

Transmission Line Impedance: The impedance into a transmission line, such as a coaxial cable, depends upon the impedance of the load  $Z_L$  as well as the length of the line  $l$  and its characteristic impedance  $Z_c$ :

$$Z = Z_c \frac{Z_L + jZ_c \tan(\beta l)}{Z_c + jZ_L \tan(\beta l)} \quad (5)$$

where  $\beta = \omega/c$  is the phase constant of propagation. When  $Z_L = Z_c$  this reduces to the characteristic impedance.

### III. QCB DESIGN AND CONSTRUCTION

The QCB was designed as a single-turn winding with many ferrite bead (FEB) chokes over straight coaxial cables, rather than as one or two large torroids with many windings, in order to make its diameter as small as possible to give the best impedance match to the ELLIPTICUS antenna cable. Figure 10 shows the finished QCB-1 assembly, with the drive cable connector on one end and the dummy cable connector on the other. The conductive (aluminum) balun tube assembly and the solid dummy output rod are also shown, with the fiberglass (G-10 phenolic) tube housing and weather cover. One output of the balun connects to the dummy rod via a banana plug; the other side is connected to the balun tube case. The exterior surfaces of the two conductors are thus driven differentially by the balun output.

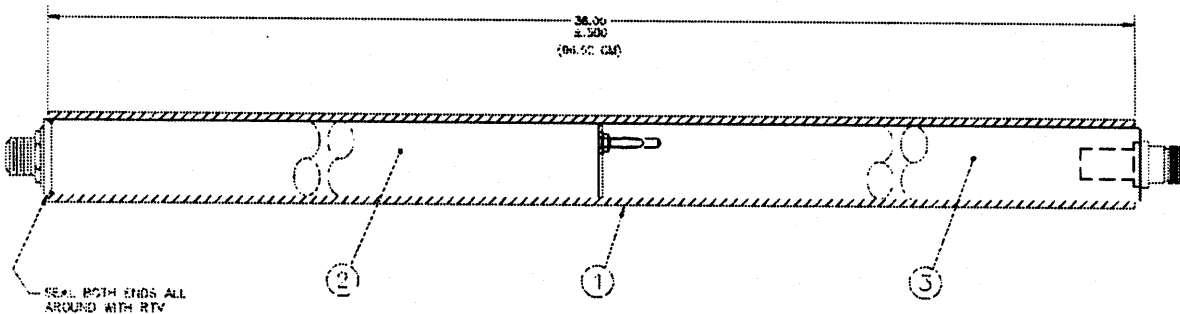

Figure 10. QCB-1 Outer Assembly.

The balun assembly is seen in Figure 11. The input is a type-N female bulkhead connector (Omni-Spectra 3004-7985-00) with a 50 ohm .085 semirigid coax (RG-405/U) extending for 8 inches down the axis of the tube. This coax is choked with a triple layer of ferrite beads: Thirty C2005-T280825T (.280 dia x .085 hole x .250 long) extremely high-frequency ferrite, thirty MC25-T502525T (.500 dia x .280 hole x .250 long) low-frequency ferrite, and nine FB77-1024 (1.000 dia x .500 hole x .820 long) low-frequency ferrite. Heat-shrink tubing is used over the beads to align, assemble, and shock-mount them.

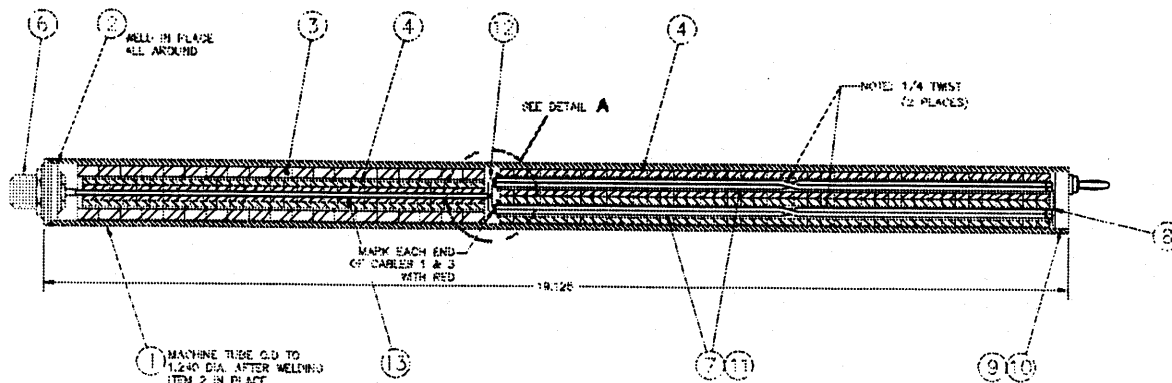

Figure 11. Balun Interior Assembly.

The dual outputs are formed from pairs of RG-405/U coax, connected as 100 ohm transmission lines as discussed above. Heat-shrink tubing is formed around each pair of coax, after they are trimmed to length and soldered together, to provide for electrical isolation. Each line is choked with forty ferrite beads: one CMD5005-T502524T, thirty-five MC25-T502825T, and four CMD5005-T502524T. The end beads are for very high frequency suppression, as well as for very high resistance isolation should the coax conductors touch the beads. Heat-shrink is used over the two lines of ferrite beads to form them into a single assembly.

The output transmission lines are connected to the input line on a small piece of printed circuit board. The assembly is then inserted into the balun tube, a rather tight fit due to the heat-shrink tubing around the beads. It is secured in the tube by the Type-N bulkhead connector at the input end and by the center plate connector at the output.

#### IV. TEST MEASUREMENTS

Measurements were made of the Quad Coaxial Balun in several of its configurations; symmetrical and non-symmetrical output loading, 100 ohm coax and dual 50 ohm coax. Measurements made include Time-Domain Reflectometry (TDR); frequency-domain transfer functions made with two network analyzers, the HP3577A from 2 kHz to 200 MHz and the HP8753C from 300 kHz to 3 GHz; and time-domain impulse

response functions. The measurement matrix is presented in the following table, with acquired data indicated. All measurements were made with a load impedance of 200 ohms resistance and the inductance minimized. It is planned to make measurements with reactive loads which mimic the antenna impedance.

	Dual 100 ohm Coax			Quad 50 ohm Coax				QCB-½
	Symmetrical		Unbal	Symmetrical		Unbalanced		Unbal
	Float	C.T.	Pos	Float	C.T.	Inv	Pos	Pos
TDR	X	X	X	X	X	X	X	X
3577A	o	o		X	X	X	X	X
8753C	o	X	X	X	X	o	X	X

These data are presented in Appendix A. They are arranged by configuration, grouped by column in the above table.

ELLIPTICUS Configuration - Unbalanced Output: The configuration for the ELLIPTICUS QCB is that of the last column, the transfer function of which is shown in Figure 12. The mid-band insertion loss is about 0.2 dB, due to the back impedance of the cables with the ferrite loading. The low frequency cutoff of 10 kHz is mostly determined by the low-frequency ferrites. The upper half-power point is at about 750 MHz; at 1 GHz the output is down by no more than 5 dB. The useful bandwidth thus is five decades of frequency.

The peaks in the transfer function are due to resonances on and within the cables in the QCB. There are two sets of resonant peaks, which can be identified on the linear frequency plot of Figure 13. The first set, identified by a dot above each peak, are at 193, 583, 971, 1358, 2127, 2513, 2895 MHz. This is a ratio of F, 3F, 5F, ●●●, with 2F ~ 385 MHz. It is tentatively attributed to the overall electrical length of the interior of the tube.

The second set of peaks are at 0, 405, 810, 1215, 1611, 2015, 2411, and 2800 MHz. The frequency step is 405 MHz, at least initially, and is attributed to the half-wave resonance of the 10 inch length of the dual 50 ohm coax used to make the 100 ohm transmission lines. This set of resonances disappears when 100 ohm coax is used, as seen in Figure 14. The general high-frequency roll-off is also less with the 100 ohm coax, apparently due to loss associated with the resonance of the 50 ohm dual coax.

Short Versions of the QCB: The design goal of the QCB was for a bandwidth of 100 kHz to 100 MHz. The first design, after some optimization of the ferrite bead configuration, exceeded this by almost a decade of frequency at each end. The resonances in the frequency response above 150 MHz are undesirable, but are of only 1-to-2 dB in amplitude to 1 GHz and therefore not a serious problem.

A shorter version of the QCB was made to see how the frequency response changes with the resonant structures changed in length. This was made to be approximately one-half the length of the prototype QCB. Figure 15 is the high-frequency response, which shows that the first resonance is about doubled, to 400 MHz. The frequency of all of the resonances actually changed by a factor of 1.9 as seen in Figure 16. The mid-band insertion loss increased by about a factor of two, to about 0.4 dB; this is due to the lower back impedance on the coax by half the volume of ferrite. The roll-off at high frequencies also increases at a faster rate on the shorter balun. The low-frequency response also changed by a factor of two, from 10 kHz to 20 kHz.

Decreasing the length of the QCB by another factor of two would double all resonances and break frequencies. The insertion loss would increase to about 0.8 dB.

## V. CONCLUSIONS

There is no doubt that 100 ohm coax makes a better balun than the dual 50 ohm configuration. the procurement or fabrication of 100 ohm coax with a center conductor of sufficient size to handle the required power should be a priority of this program.

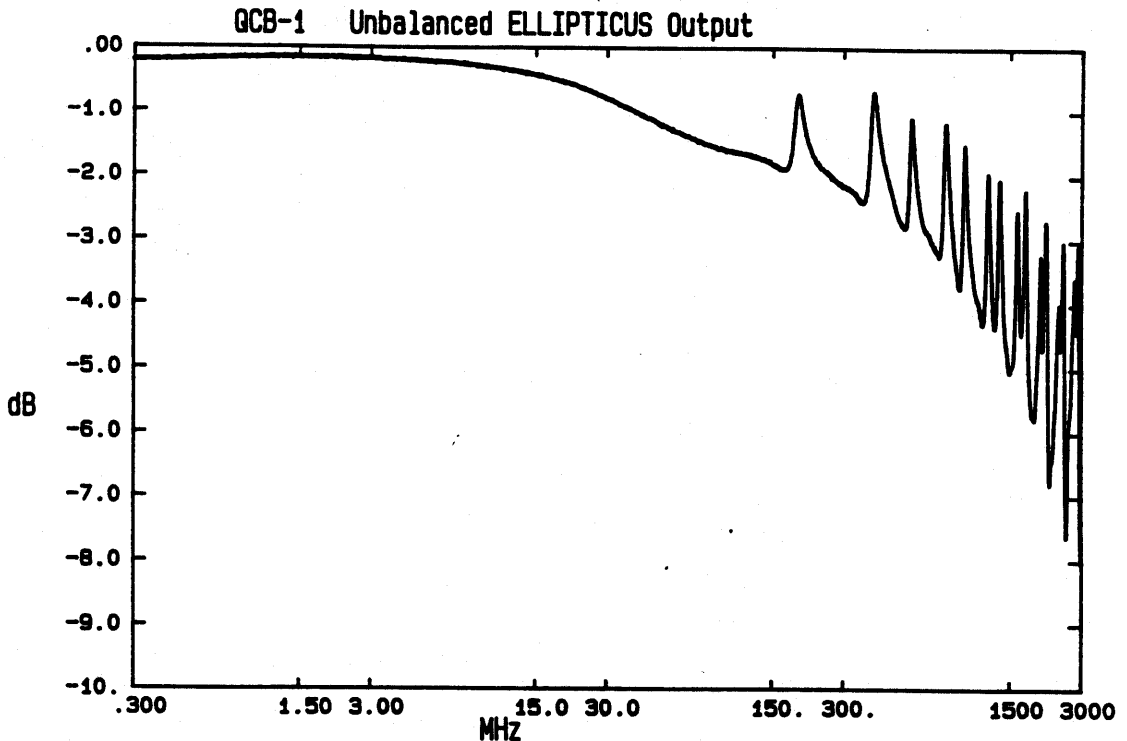
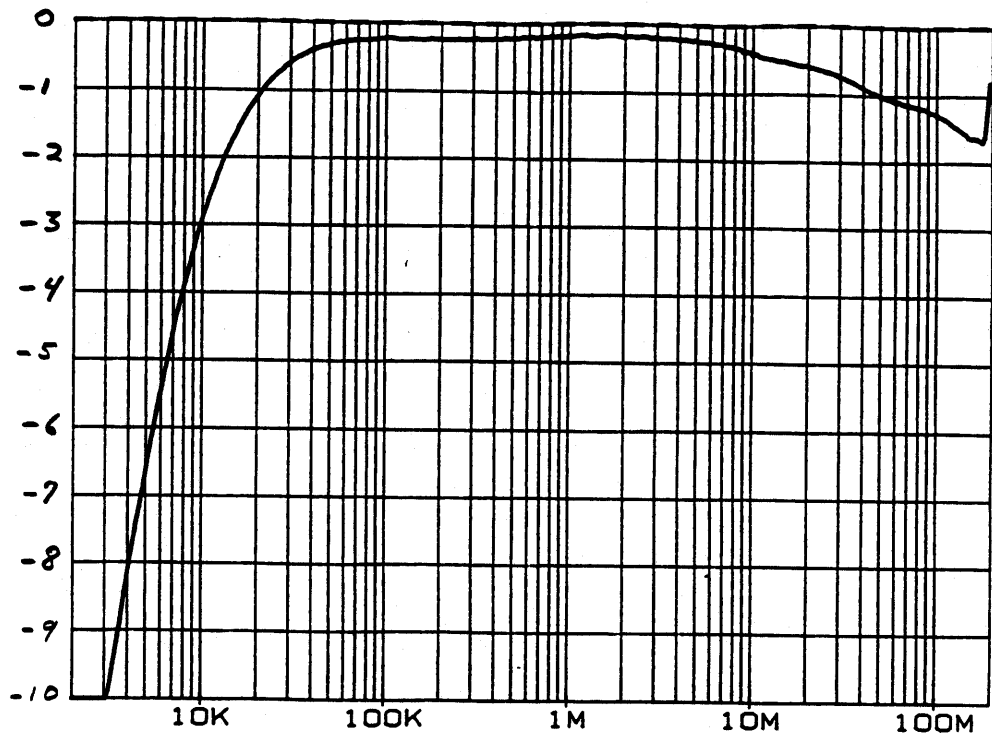

**Figure 12. Transfer Function of QCB with Unbalanced Output for ELLIPTICUS.**

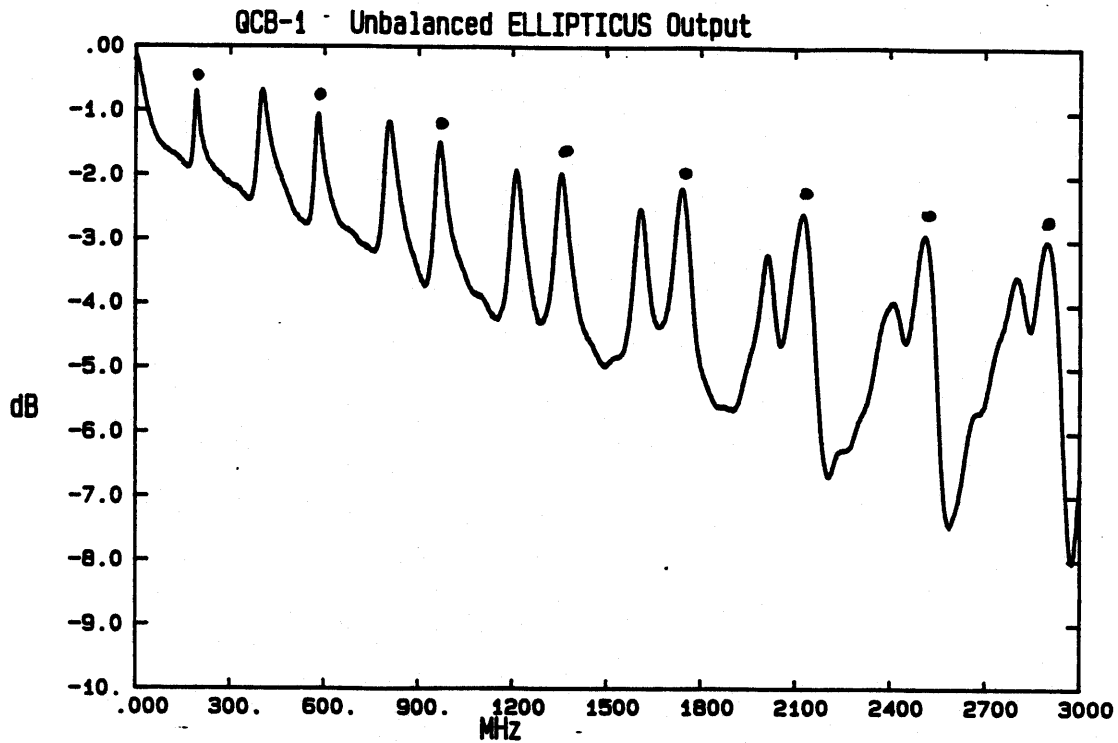

Figure 13. Linear Frequency Transfer Function of QCB with Unbalanced Output for ELLIPTICUS.

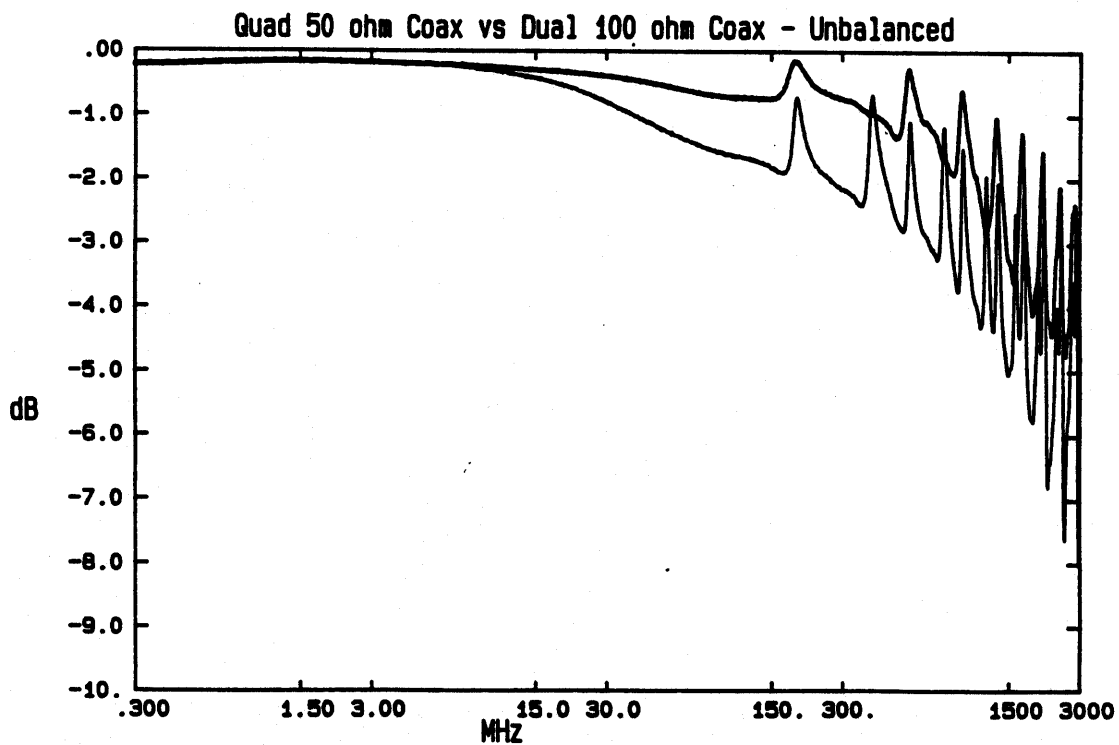

Figure 14. Comparison of Resonances for the Two Coax Configurations.

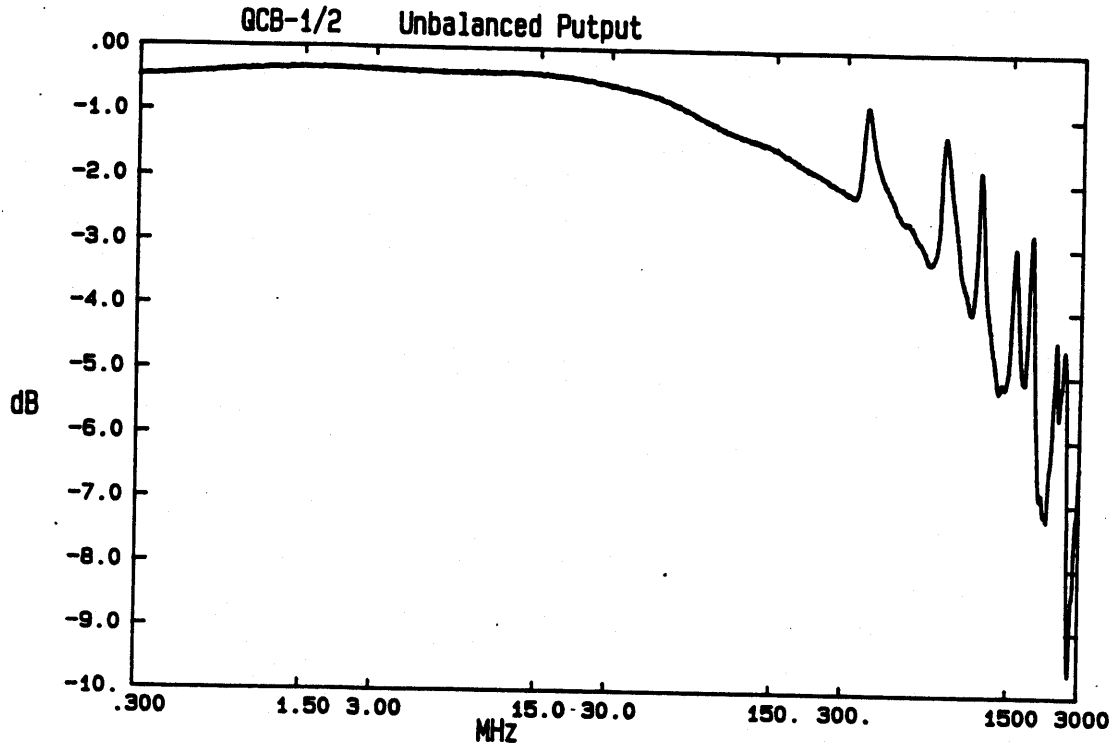

Figure 15. Transfer Function of Half-Length QCB.

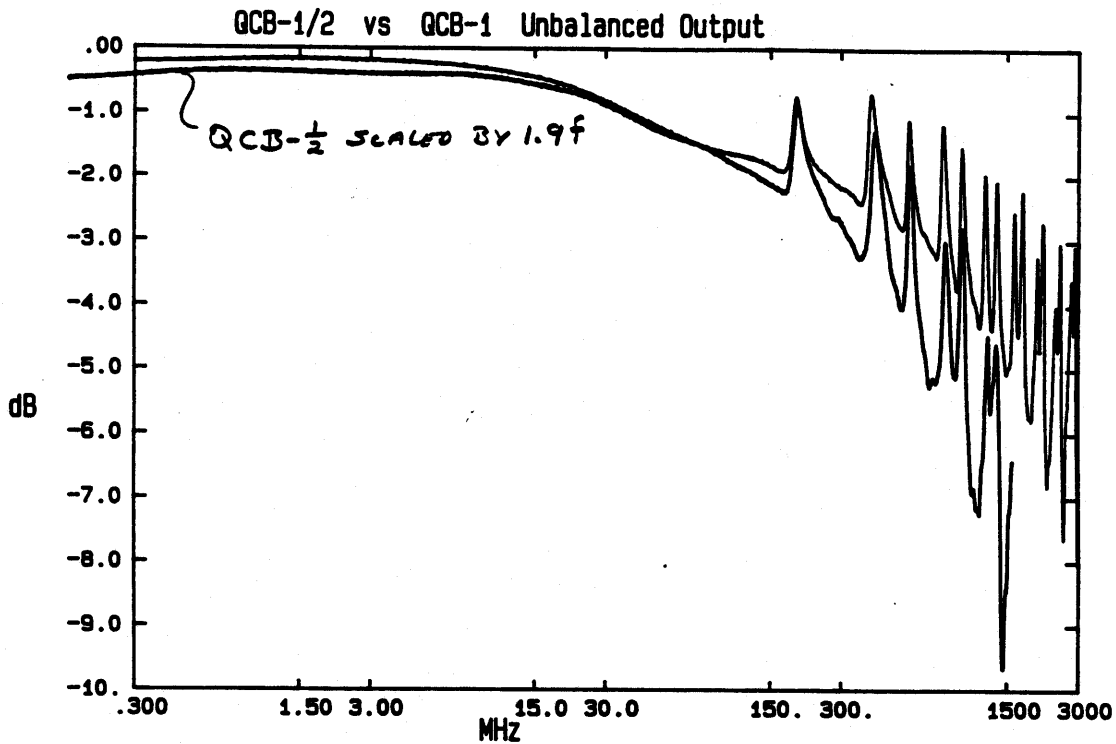

Figure 16. Comparison of Resonances with QCB Length.