

**Measurement Notes**

Note 34

3 June 1987

**Twin Coaxial Balun (TCB) Development**

G. D. Sower  
L.M. Atchley

EG&G Washington Analytical Services Center, Inc.

**ABSTRACT**

The Twin Coaxial Balun (TCB) is a transformer which accepts a signal, either pulse or CW, from a 50-ohm power amplifier and converts it to differentially (push-pull) drive a pair of symmetric 100-ohm transmission lines. This note describes the manufacture and response of the TCB-1A, as built to the specifications of AFWL Measurement Note 31.

**CLEARED**  
**FOR PUBLIC RELEASE**  
AFWL/PA 7-22-87

87-332  
Air Force Weapons Laboratory  
Office of Public Affairs  
Kirtland AFB, NM 87117-6008

## I. INTRODUCTION

The TCB-1A is shown in Figure 1. The Twin Coaxial Balun has two fundamental functions: transform the unbalanced single-ended input to two balanced outputs, and transform the impedance from 50-ohms at the input, to 100-ohms at each output. The TCB is used to connect a 50-ohm output-impedance device, such as a power amplifier, to the differential input of a higher impedance device, such as a balanced antenna. Should the impedance of the output device be greater than 200-ohms, additional impedance matching, possibly in the form of a resistive pad, may be required.

The TCB is a transformer, specifically a pulse or broadband transformer, with a highly permeable core to provide a path for magnetic flux linkage between the primary and secondary windings. The bandwidth of this transformer is maximized by using a large, high permeability core to give a large winding inductance and hence give good low-frequency response. At high frequencies, the leakage inductance, or loss of flux linkage between primary and secondary windings, is minimized by forming the windings from coaxial cable, so that the inner conductor forms one winding and the outer conductor the other.

CLASSIFIED  
FOR PUBLIC RELEASE



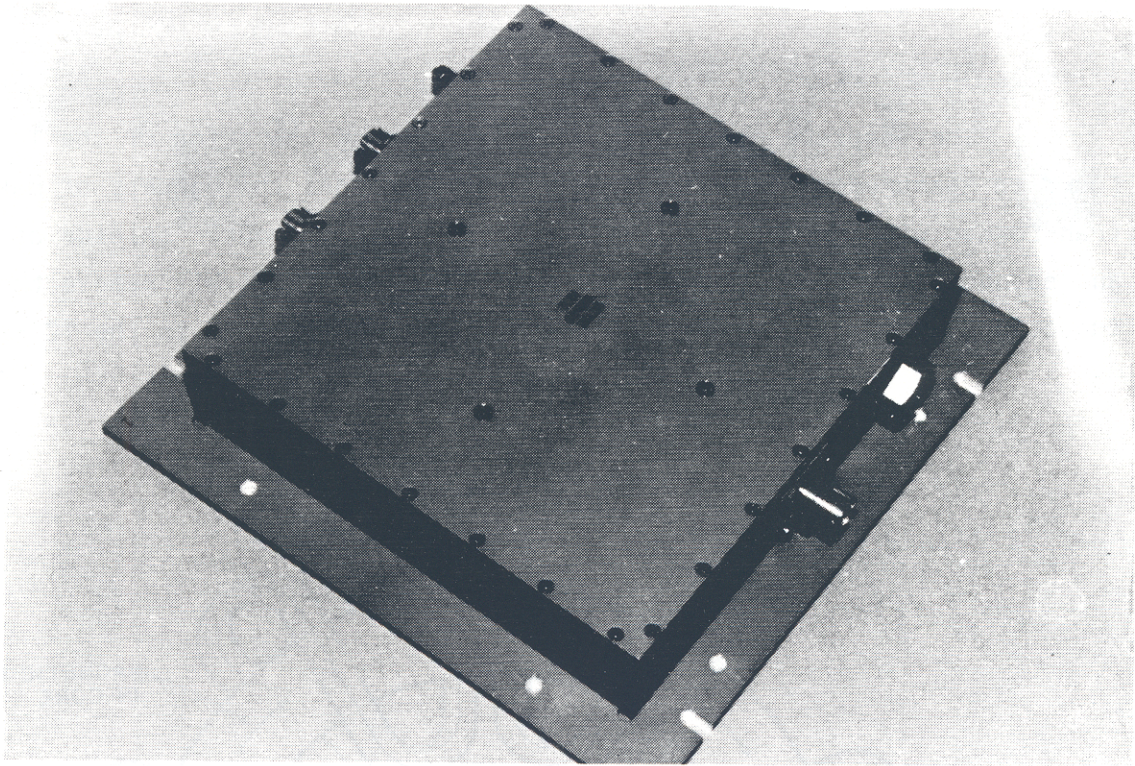

a. Finished TCB-1A

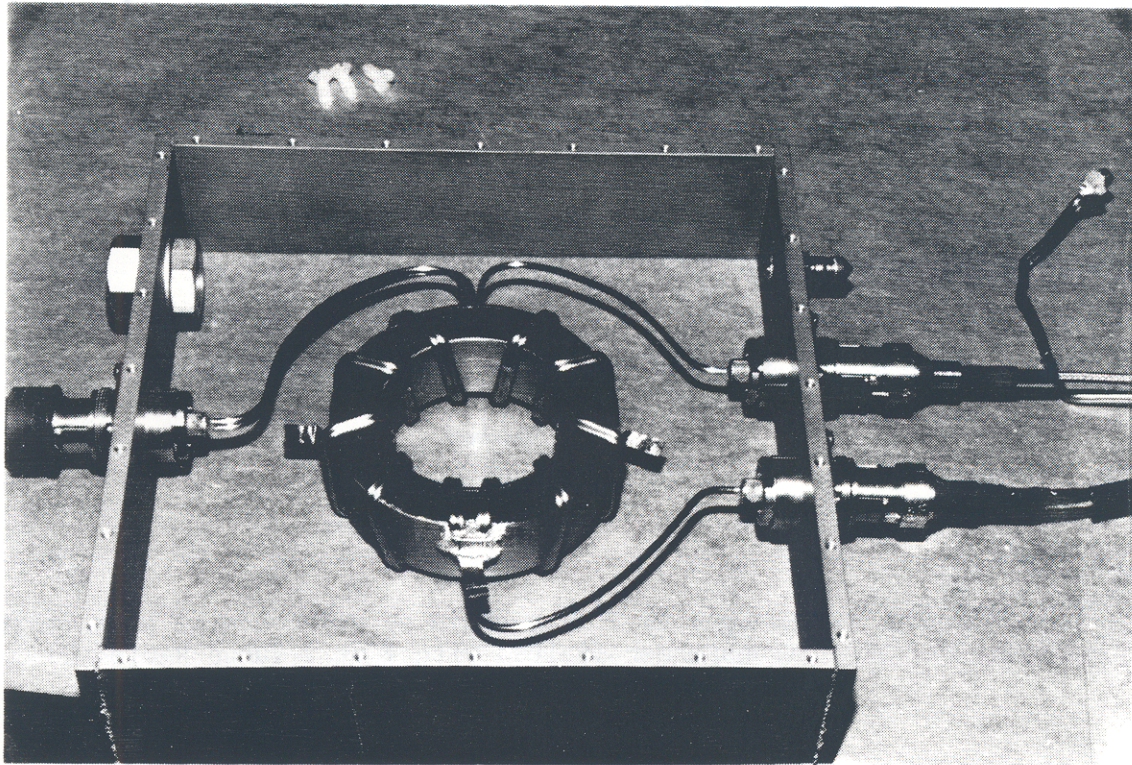

b. TCB-1A Interior

Figure 1. Twin Coaxial Balun



## II. THEORY OF OPERATION

The complete discussion of the theory of operation of the TCB-1A is found in Measurement Note 31<sup>1</sup>. That note discusses the concept of making the transformer windings out of coaxial cables, with the outer shields of primary and secondary windings bonded together so as to effectively remove the leakage inductance. Figure 2 shows the winding geometry employed in the TCB-1A.

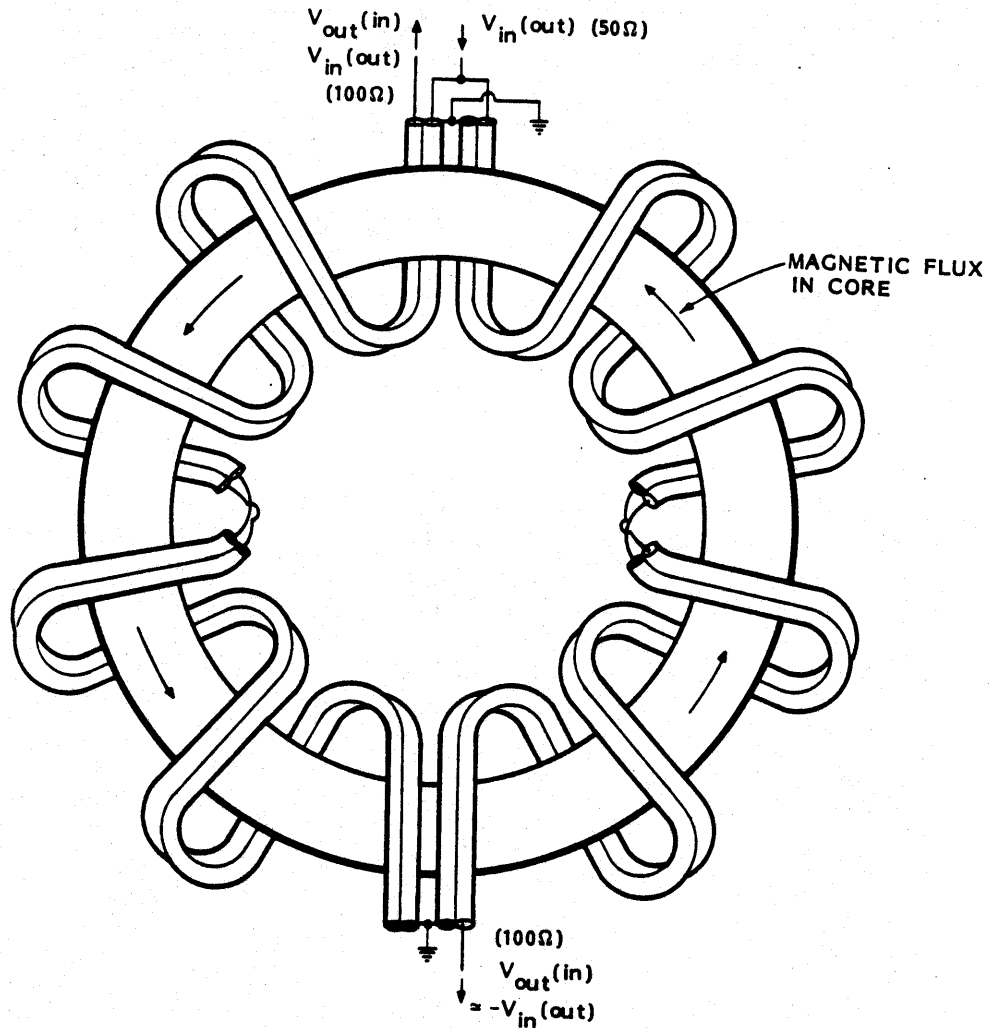

Figure 2. Example of Single-ended to differential Twin Coaxial Transformer (Balun) with 1 to 2 Turns Ratio

<sup>1</sup>C.E. Baum, Measurement Note 31, "Winding Topology for Transformers," AFWL, 2 October 1986.

The two windings are connected so that the input signals (primary windings) are connected in parallel, but the output signals (secondary windings) are in series (differential output) for each winding. This gives a transformer ratio of 1 to 2 (single ended to differential). In this case the two primary-winding transmission lines have a net parallel impedance  $Z/2$ , while the secondary-winding transmission lines have a net series impedance (differential)  $2Z$ . The TCB-1A has two twin-coaxial windings, each of 5 turns. Note that the direction of magnetic flux density in the core is maintained by the sense of both windings. At the ends of the windings the shields of the two windings are connected together and to ground (the local external shield containing the transformer). Note that no additional conductors pass through the transformer core because such would create an additional winding (shorted turn) on the transformer.

Figure 3 shows the TCB-1A cable connections, unwrapped from the core for clarity. Each segment of coaxial cable forms a transformer when wrapped on the core, with the center conductor forming one winding (primary or secondary) and the interior of the shield forming the other winding (secondary or primary). The two coaxes forming the twin coax of the non-inverting output share a connected shield, but the signals inside of the coax are not coupled by the magnetic flux of the core.

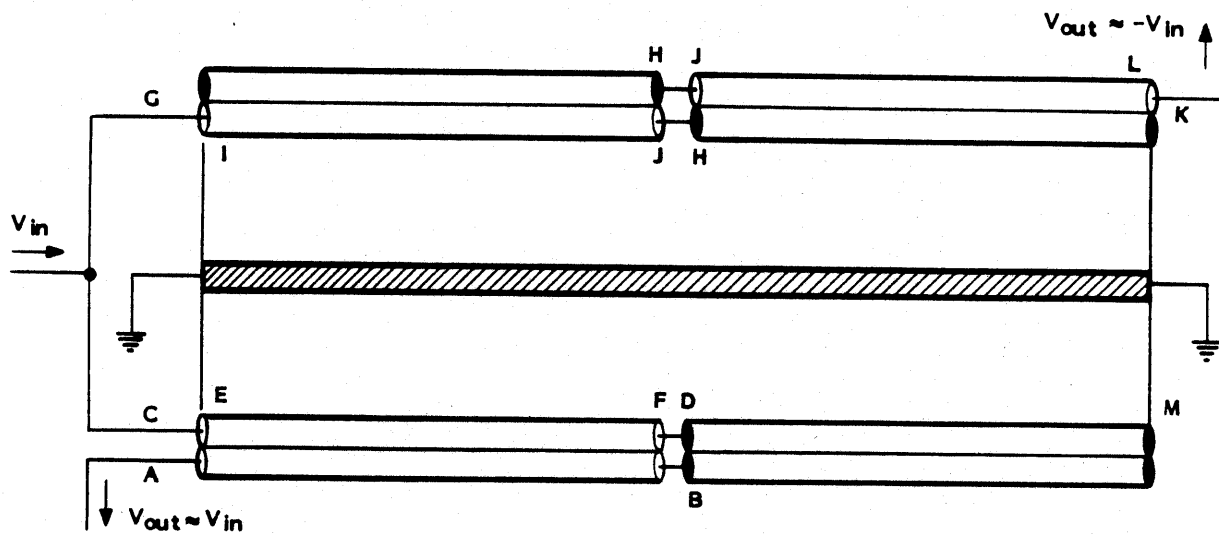

Figure 3. TCB-1A Cable Connections

Figure 4 shows the equivalent circuit of the signal paths, inside the coax. If these were the only possible signal paths, the TCB-1A would work perfectly even without the magnetic core. Unfortunately, this does not occur because currents can flow on the exterior of the coax shield,

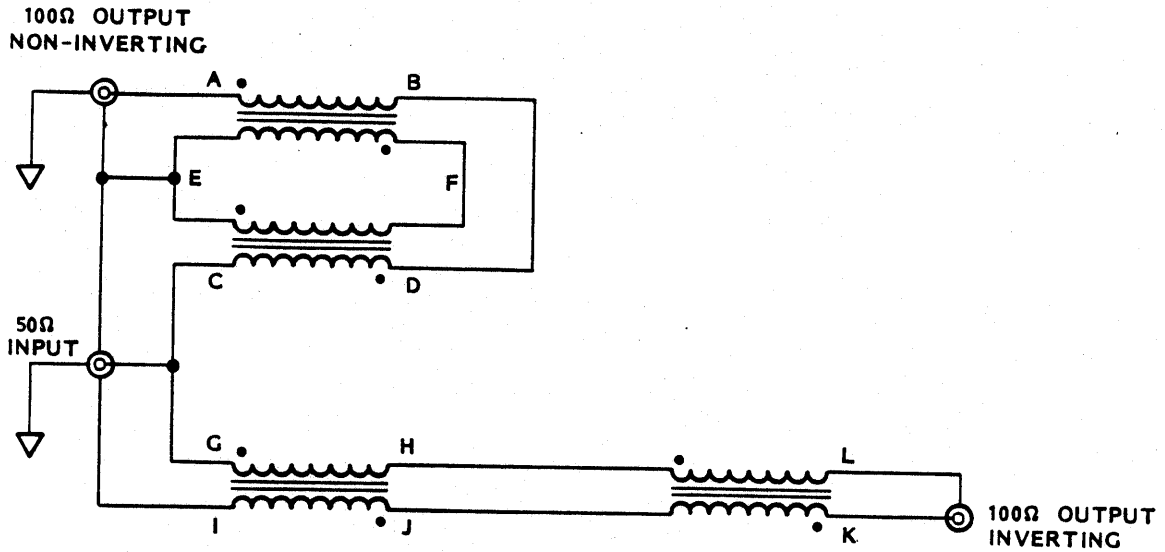

Figure 4. Equivalent Circuit of Signal Paths

reducing the currents driven into the coax. Indeed, the shield exteriors form transmission lines, both with respect to each other and to the metallic case which holds the TCB-1A core. The purpose of the magnetic core is therefore to squelch these exterior currents.

Figure 5 shows the equivalent circuit of the TCB-1A shields, wound on the magnetic core. Two of the windings are in parallel, and these two oppose the other pair of windings. Thus the flux in the core generated by the shield currents should sum to zero, forcing all of the shield currents to zero.

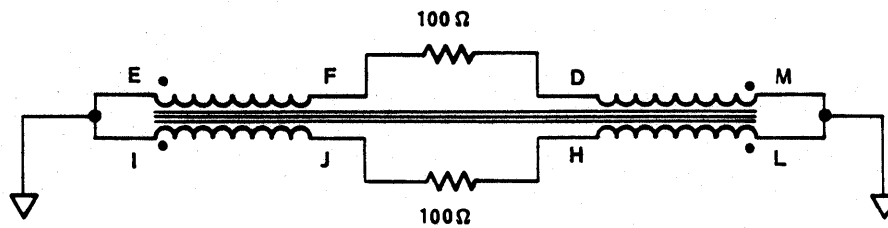

Figure 5. Equivalent Circuit of Coax Outer Shields.

The low-frequency response of the TCB-1A is determined by the inductance of each winding on the core. This magnetizing inductance is given by

$$L_m = \mu N^2 w \ln \left( \frac{b}{a} \right)$$

where  $\mu = \mu_r \mu_o$  is the core permeability,  $N$  is the number of turns of the winding,  $w$  is the core thickness,  $b$  is the core outer radius, and  $a$  the inner radius. The core material was chosen to be Metglass, which has a very high initial permeability of about 13,000. Each winding is composed of 5 turns. The core geometry thus gives a magnetizing inductance value of about 44  $\mu$ H. This inductance is effectively in parallel with the load resistance of each winding of 100 ohms, so the current delivered to each output is given by

$$\frac{I}{I_o} = \frac{s}{s + R_L/L_m}$$

where  $I_o$  is the current input to the winding and  $s$  is the Laplace frequency. The low-frequency break frequency (-3 dB point) is thus at

$$\omega = 2\pi f = \frac{R_L}{L_m},$$

which is at about 360 kHz.

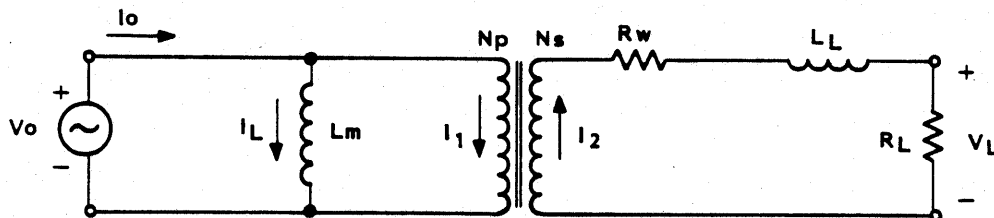

- $L_m$  = Magnetizing Inductance
- $R_w$  = Winding Resistance ( $\approx 0$ )
- $L_L$  = Leakage Reactance ( $\approx 0$ )
- $R_L$  = Load Impedance

Figure 6. TCB-1A Equivalent Circuit

### III. DESIGN AND CONSTRUCTION

The TCB-1A was developed according to the design in Reference 1. The primary considerations were the selection of the magnetic core and the winding of the 100-ohm coaxial cables.

The core material chosen for the TCB-1A is Metglass 2605S3. This material was selected for its very high saturation level its very high initial permeability, and its round hysteresis loop which results in very low core loss at high frequencies. The selected core is identical to the one used in the AFWL lightning stinger OCP current probe<sup>2</sup>. The .002 cm thick Metglass ribbon is wound with a 6.350 cm ID, 8.890 cm OD, and 2.540 cm thickness, and is held in an aluminum cavity as shown in Figure 7.

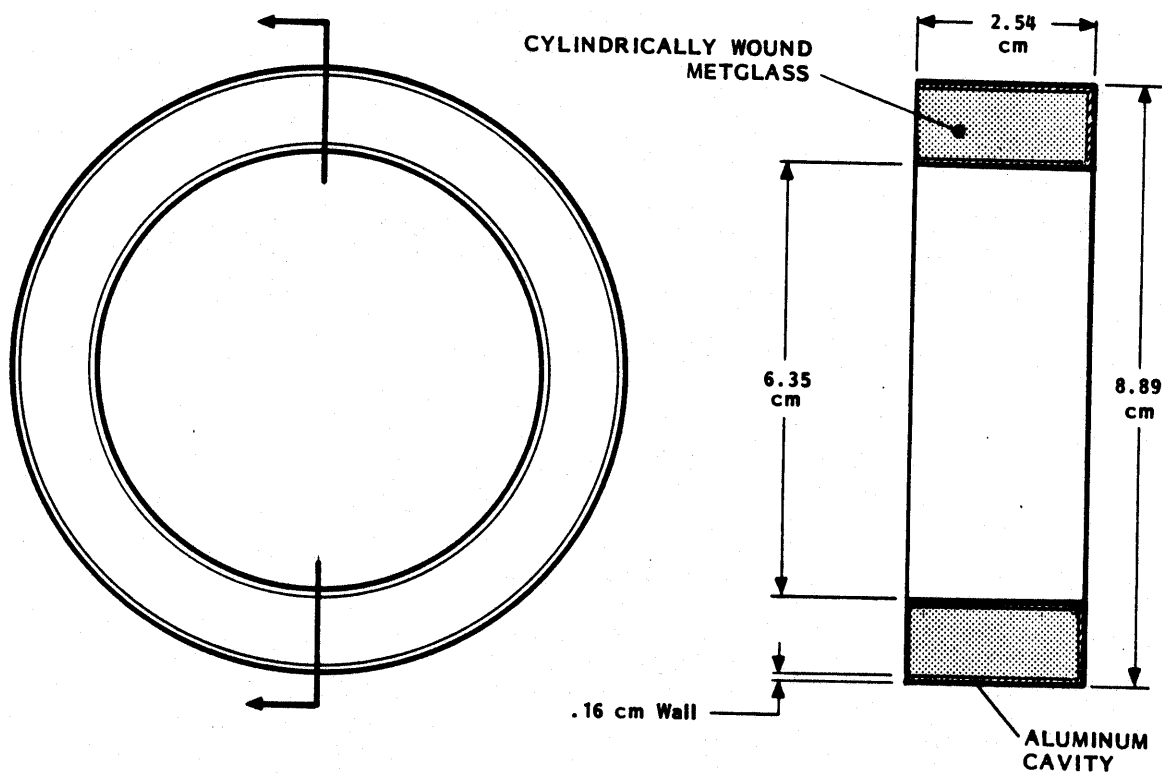

Figure 7. Metglass Core Details

<sup>2</sup>C.E. Baum, J.P. O'Neill, G.D. Sower, E.L. Breen, I.J. Caylor, D.L. Hall, and C.B. Moore, "KIVA 2 Lightning Current Measuring Sensor Array", KIVA Memo 4, AFWL, January 1984.



The initial permeability of this Metglass is about 13,000 times free-space permeability. The term "initial" refers both to the low-frequency limit and to the low-magnetic flux limit. At frequencies above a few MHz the permeability decreases, becoming  $\mu_0$  above 100 MHz - the exact permeability vs frequency curve for this material is not available for this report (available data for magnetic materials seem to stop at a few MHz). The permeability also is a function of the magnetic flux in the material, and in general will increase to a maximum from the initial value as the flux increases, and then decrease drastically with still higher flux as the core saturates.

The Metglass material chosen has a linear response at flux levels below about 1.5 T. Above this flux level, saturation starts to occur ( $\mu$  decreases), and full saturation occurs at about 4 T. Saturation of a transformer core is expressed in term of the "I-cross-t product", which defines the input signal required to drive the ferromagnetic material into saturation, given by

$$(Ixt) = \frac{N_s^2}{N_p} \frac{A_{cs}}{R_L} \cdot B_{SAT}$$

where  $A_{cs}$  is the core cross-section area and  $R_L$  the load resistance. For a CW signal,

$$(Ixt) = \frac{2\sqrt{2} I_o}{\omega}$$

where  $I_o$  is the RMS current level into the transformer. For our 5-turn windings,  $(Ixt) \approx 1.2 \times 10^{-5}$  A -s. At the lowest frequency specified for the TCB-1A, 100 kHz,  $I_o \approx 2.7$ A (each winding). This is 5.4 A into a 50-ohm load, or over 1000 W core power loading capability.

The TCB-1A windings are made from 100-ohm semirigid coax, .090 inch (0.229 cm) diameter. Two such coax were soldered together at short intervals to form the twin coax. They were then covered with dielectric (heat shrink) to prevent turns from shorting and to maintain close spacings between windings

and core and to reduce shunt loading at the gaps, and wound on the core. The solid wires, used for symmetry, were made by soldering shut the ends of the coax. Figure 1 shows the wound core.

Care must be taken in the use of the TCB-1A. It cannot deliver at the output terminals 100W of power for continuous periods of time because of the small size of the coax inner conductor. Its large resistance causes it to heat up, which causes the teflon insulation to heat and swell, breaking the jacket.

The TCB-1A is housed within an aluminum enclosure as shown in Figure 8. It is secured within the housing by dielectric supports. GR874 connectors are used for the input and output connections with a 50-ohm center conductor for the input and 100-ohm conductors for the outputs. A gas fill valve and a pressure relief valve are included so that it can be filled with SF<sub>6</sub> to prevent breakdown at the connections. The lids of the enclosure are sealed with a gas-tight, EMI gasket to retain the gas.

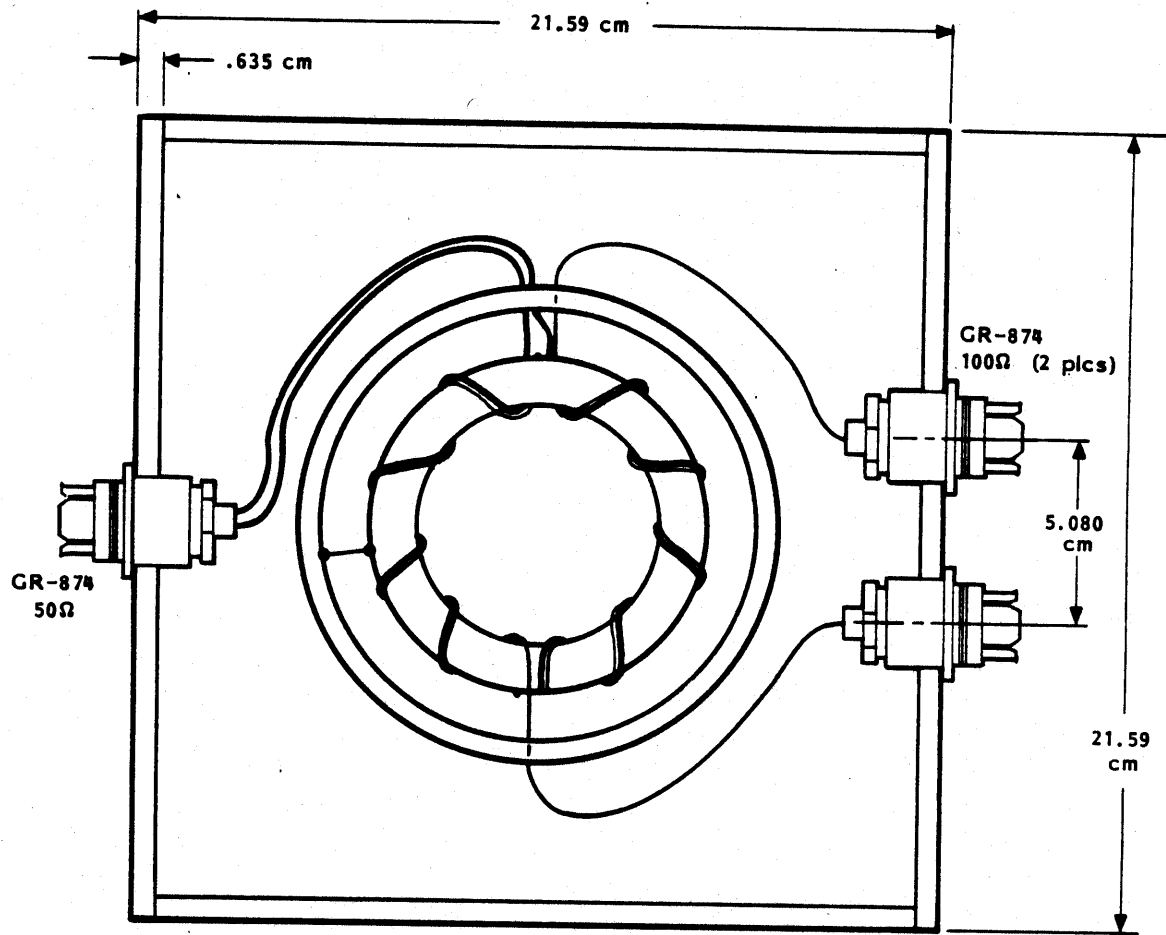

Figure 8. The TCB-1A is housed within an Aluminum Enclosure

#### IV. BALUN RESPONSE

Measurements were made on the TCB-1A for TDR response, pulse response, and frequency-domain response.

Time Domain Reflectometry (TDR) is a technique which can be used to measure a device characteristic impedance by means of injecting a step pulse into the drive and monitoring the reflections of this step back out of the device. Figure 9 shows the TDR of the TCB-1A input. The first 1 ns of the trace is the impedance of the 50-ohm cable from the TDR. The input to the TCB-1A is seen by the two inductive spikes. The connection to the two 100-ohm coax is seen by an inductive spike, due to the exposed center conductors. The impedance then remains 50-ohms through the parallel 100-ohm coax, until the gaps are reached. At the gaps there is a significant reduction in impedance due to signal coupling onto the parallel-path transmission lines found by the coax outer shields to each other and to the core. These transmission lines are relatively short, running only part way around the core cross section before they are interrupted by the gap in the core shield. At these interruptions, part of the errant signal is reflected back to the coax as manifested by the "ring-up" back to 50-ohms which lasts for approximately 1 ns.

Figures 10 and 11 show the TDR of the two TCB-1A outputs, with the other terminals either terminated or open so as to show their locations. Again, the 50-ohm input cable from the TDR is seen. Then about 2 ns of 100-ohm coax is seen, followed by an impedance inductive spike at the gaps. The transmission lines found by the outer shields add a shunt impedance to this signal path, so the impedance between the gaps at the input connection decreases significantly from 100 ohms. At the input connection, the same phenomenon occurs as that at the gaps when TDR'ed from the input, with the same characteristic "ring-up". Then, the other 100-ohm coax and the 50-ohm input are in parallel, and the signature eventually rings down to 33 ohms.

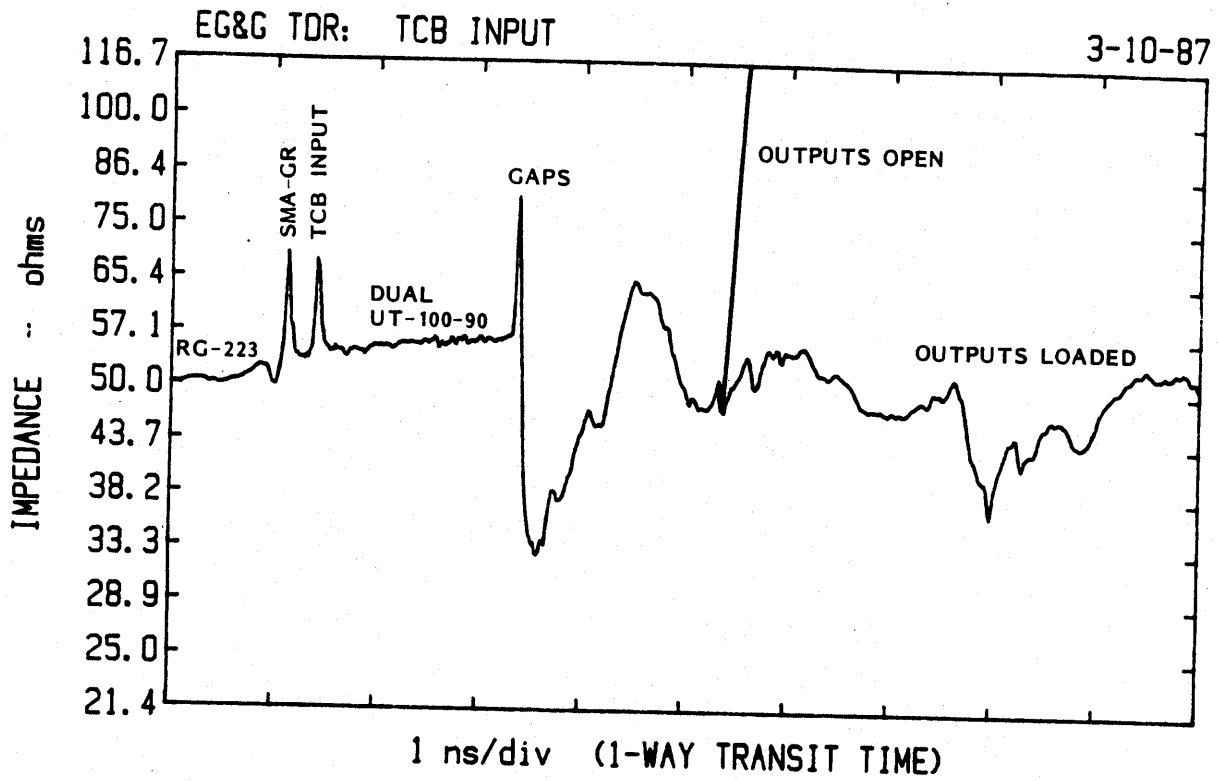

Figure 9. TDR of TCB-1A Input

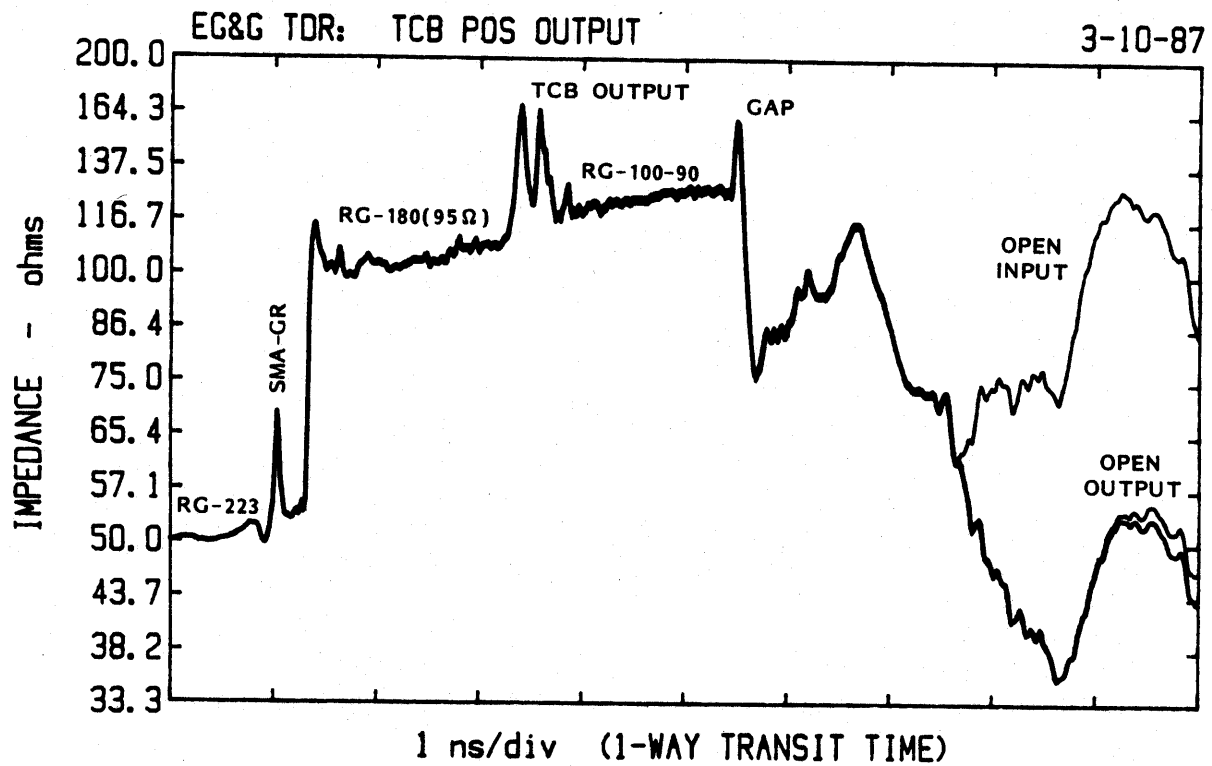

Figure 10. TDR of TCB-1A Positive Output



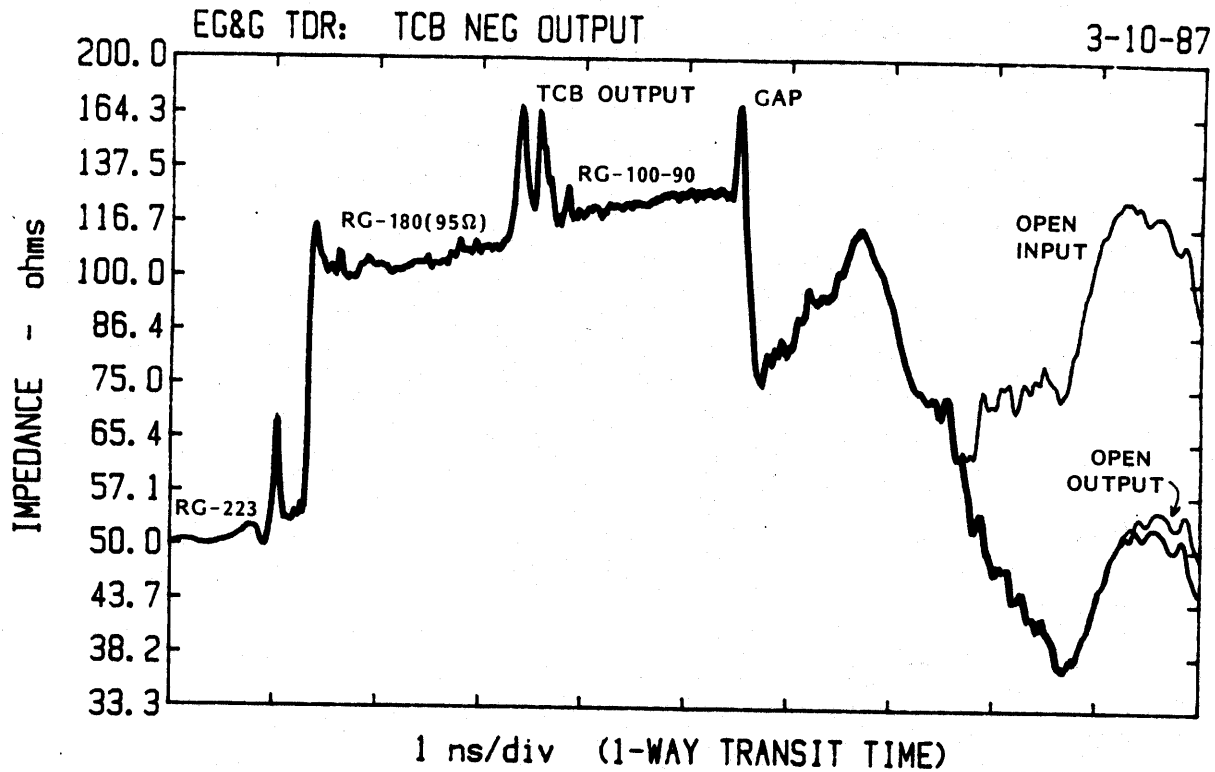

Figure 11. TDR of TCB-1A Inverting Output

The TCB-1A was built for a swept-frequency excitation program, but should also find applications in pulse-excitation work. Figures 12 and 13 show the pulse response of the TCB-1A. Figure 14 and 15 show the impedance response. The two outputs are seen to be initially identical. The output rise time of the TCB-1A is approximately 2 ns.

The TCB-1A frequency-domain data were all taken on HP 3577A Network Analyzers. Figure 16 shows the transfer function (output/input) for the inverted output and Figure 17 for the non-inverted output. Figure 18 is the difference between the two signals, the differential output. Figure 19 is the sum of the two outputs, the common-mode output signal.

The TCB-1A is seen to be within 1 dB of the ideal output for all frequencies between 1 and 100 MHz. It is within 3 dB of its peak between 100 kHz and 200 MHz.

Figures 20 and 21 show the phase of the two TCB-1A outputs.

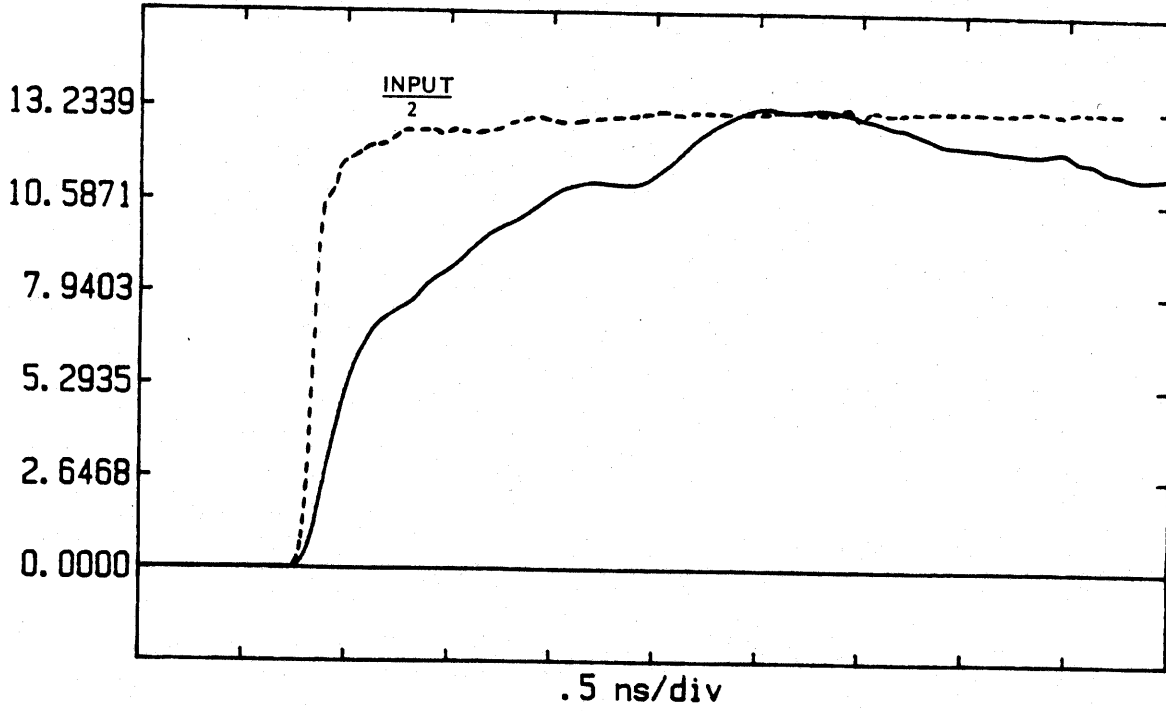

Figure 12. TCB-1A Positive Pulse Response

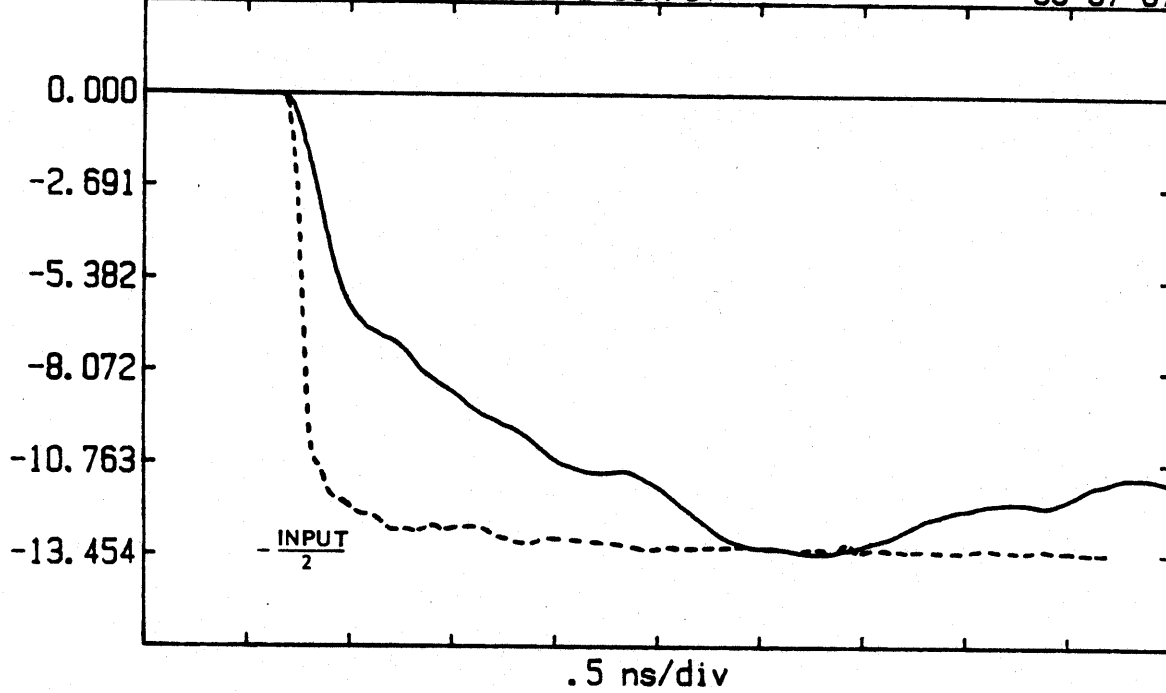

Figure 13. TCB-1A Inverting Pulse Response

EG&G SAMPLER: TCB IMP 3 OUTPUT

MAR 7 1987

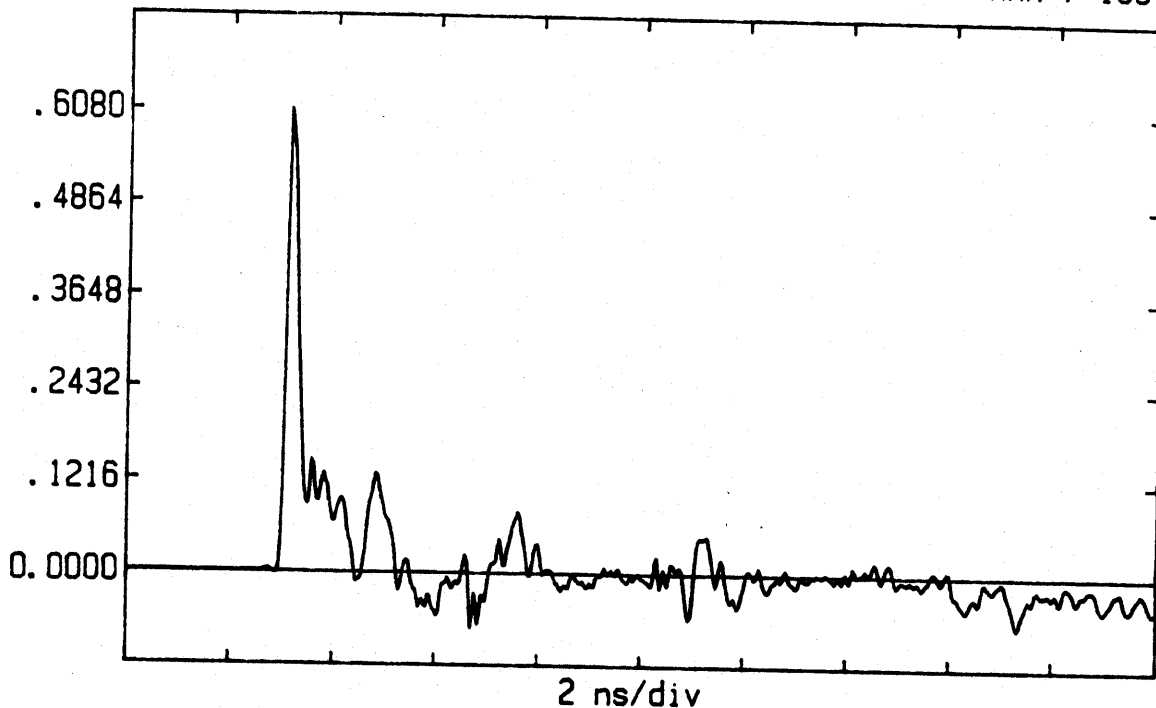

Figure 14. TCB-1A Positive Output Impulse Response

EG&G SAMPLER: TCB IMP-3 OUTPUT

03-07-87

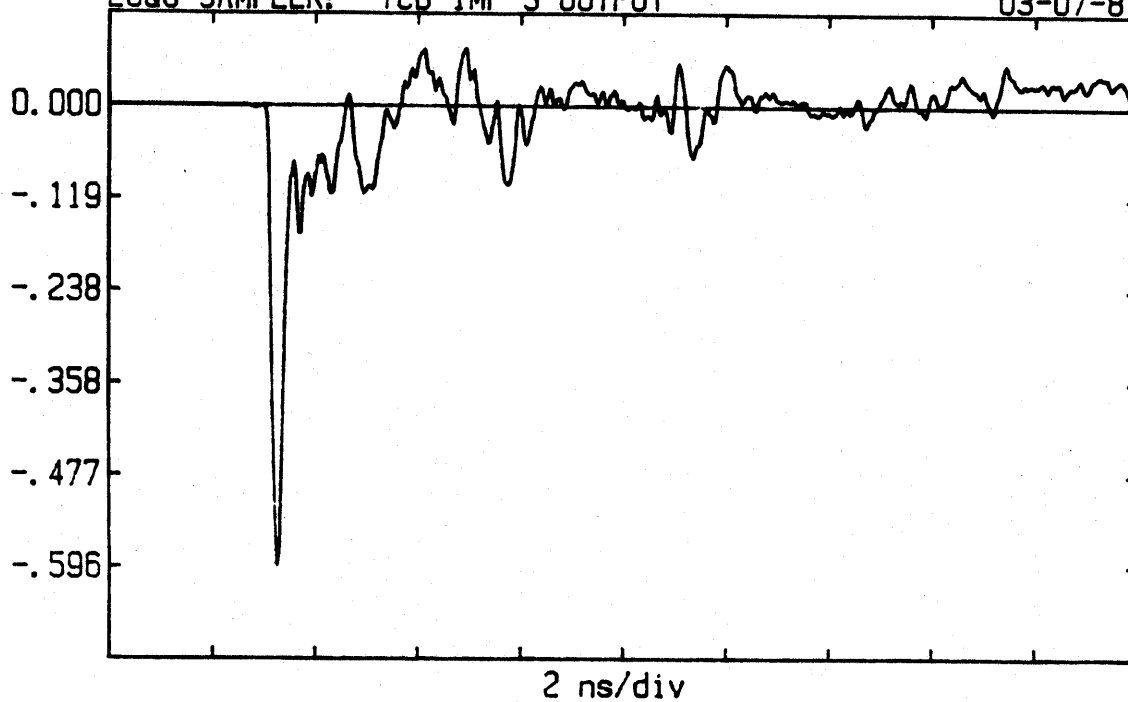

Figure 15. TCB-1A Inverting Output Impulse Response

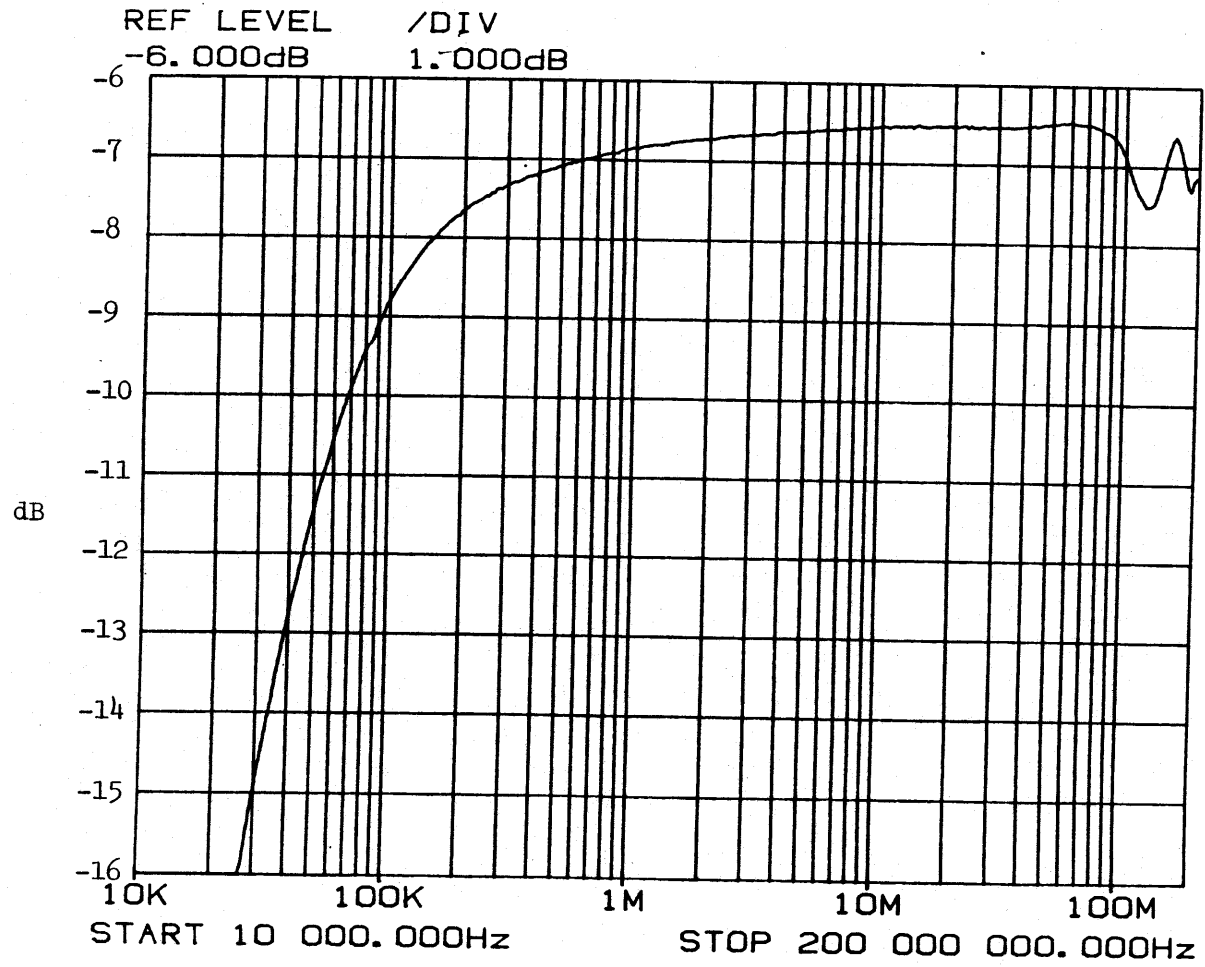

Figure 16. TCB-1A Inverting Output

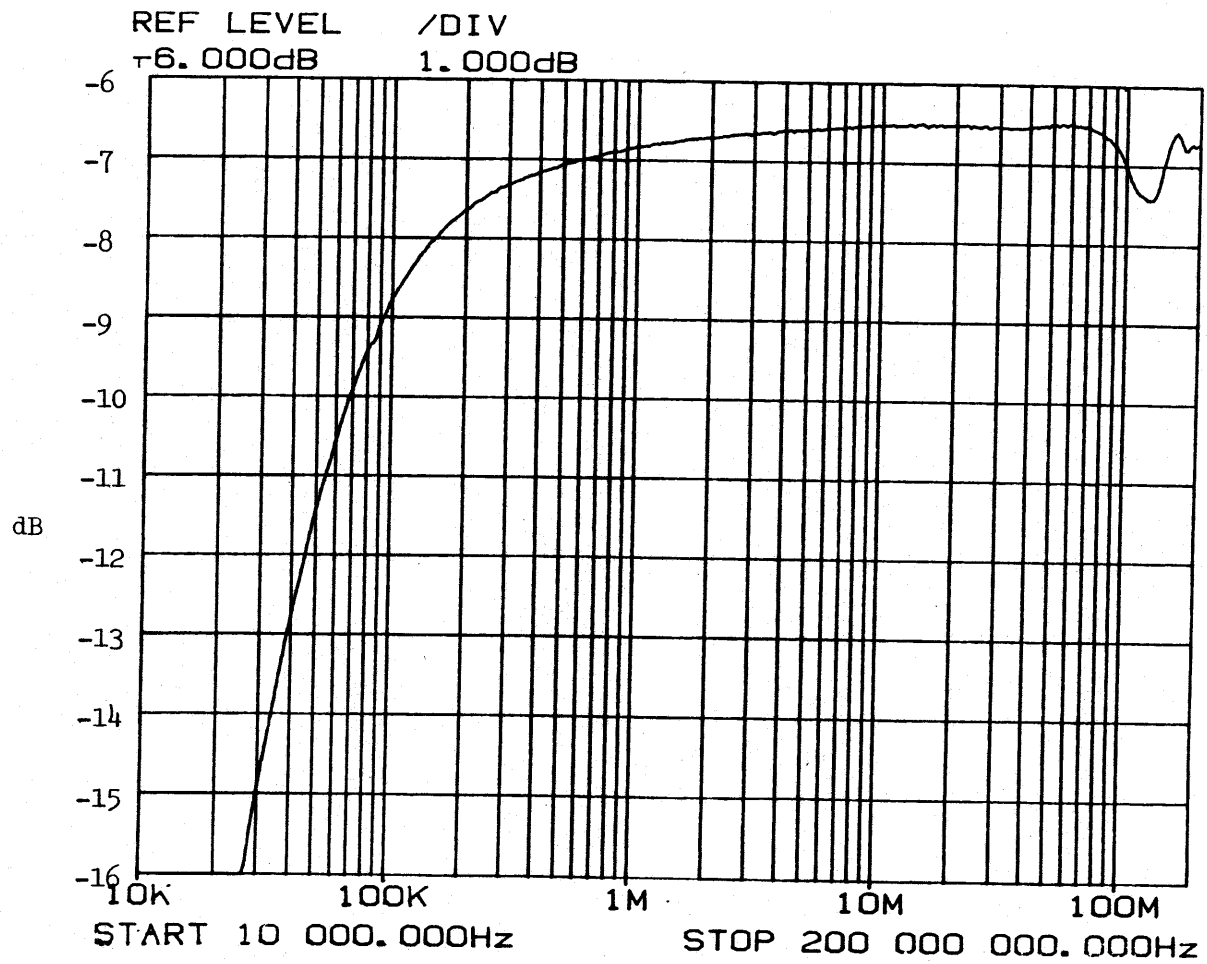

Figure 17. TCB-1A Non-Inverting Output



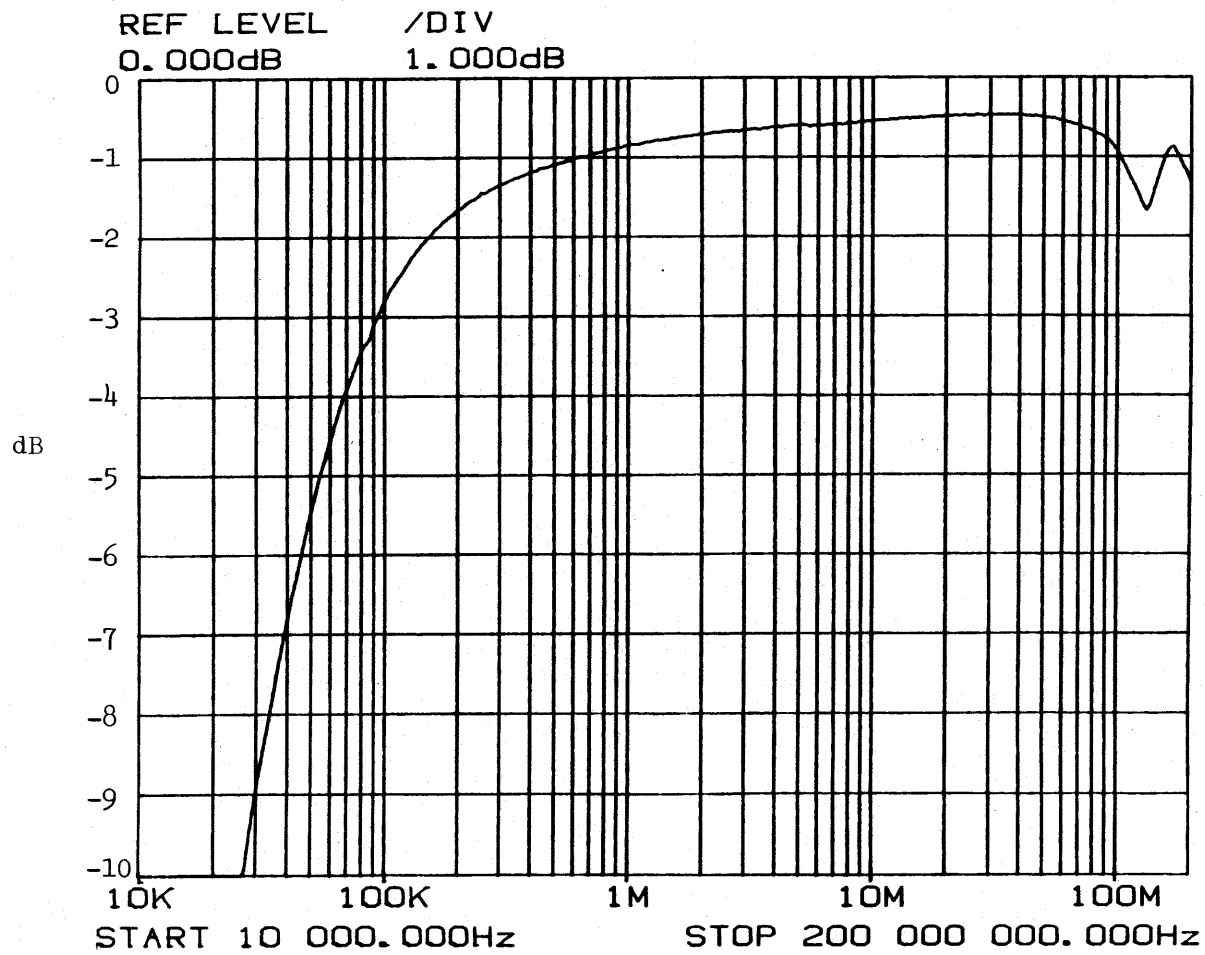

Figure 18. TCB-1A Differential Output

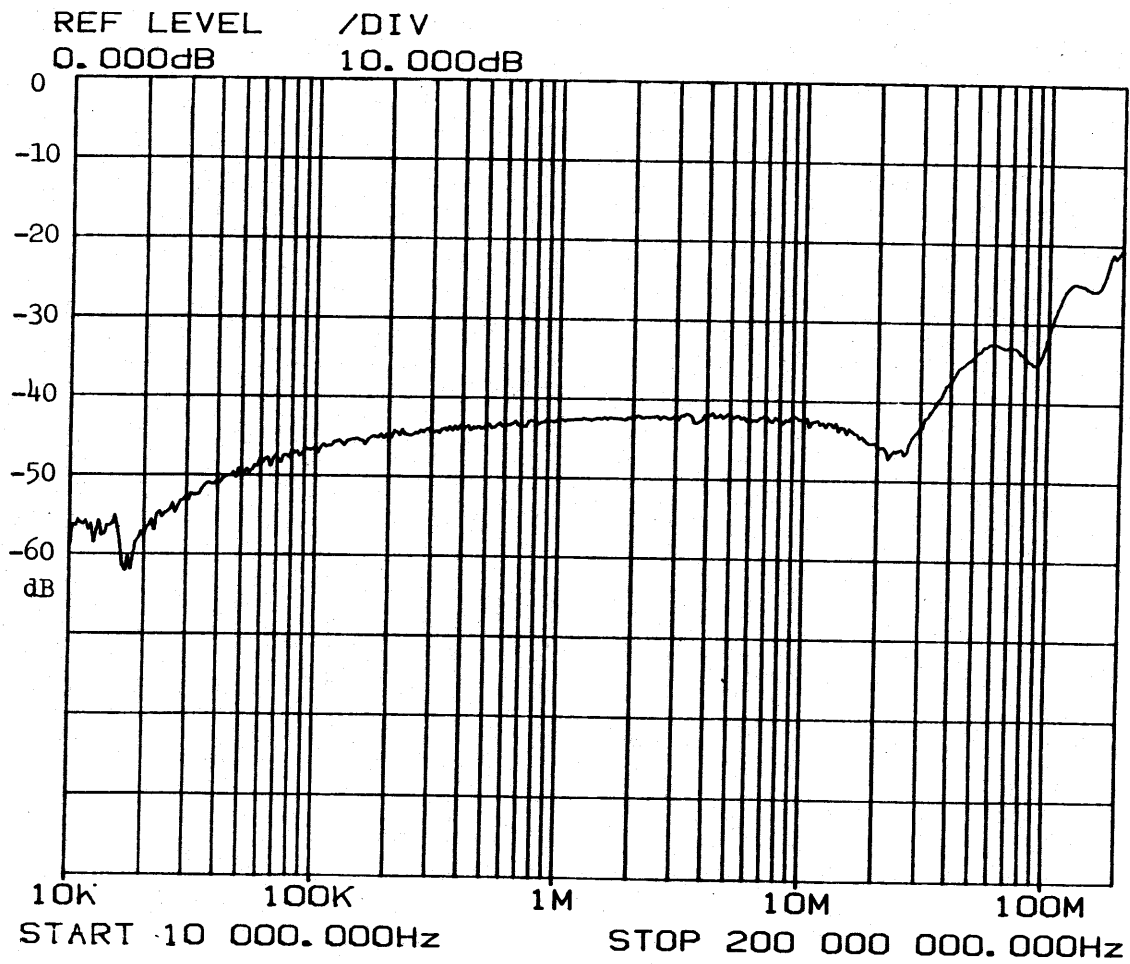

Figure 19. TCB-1A Common-Mode Output

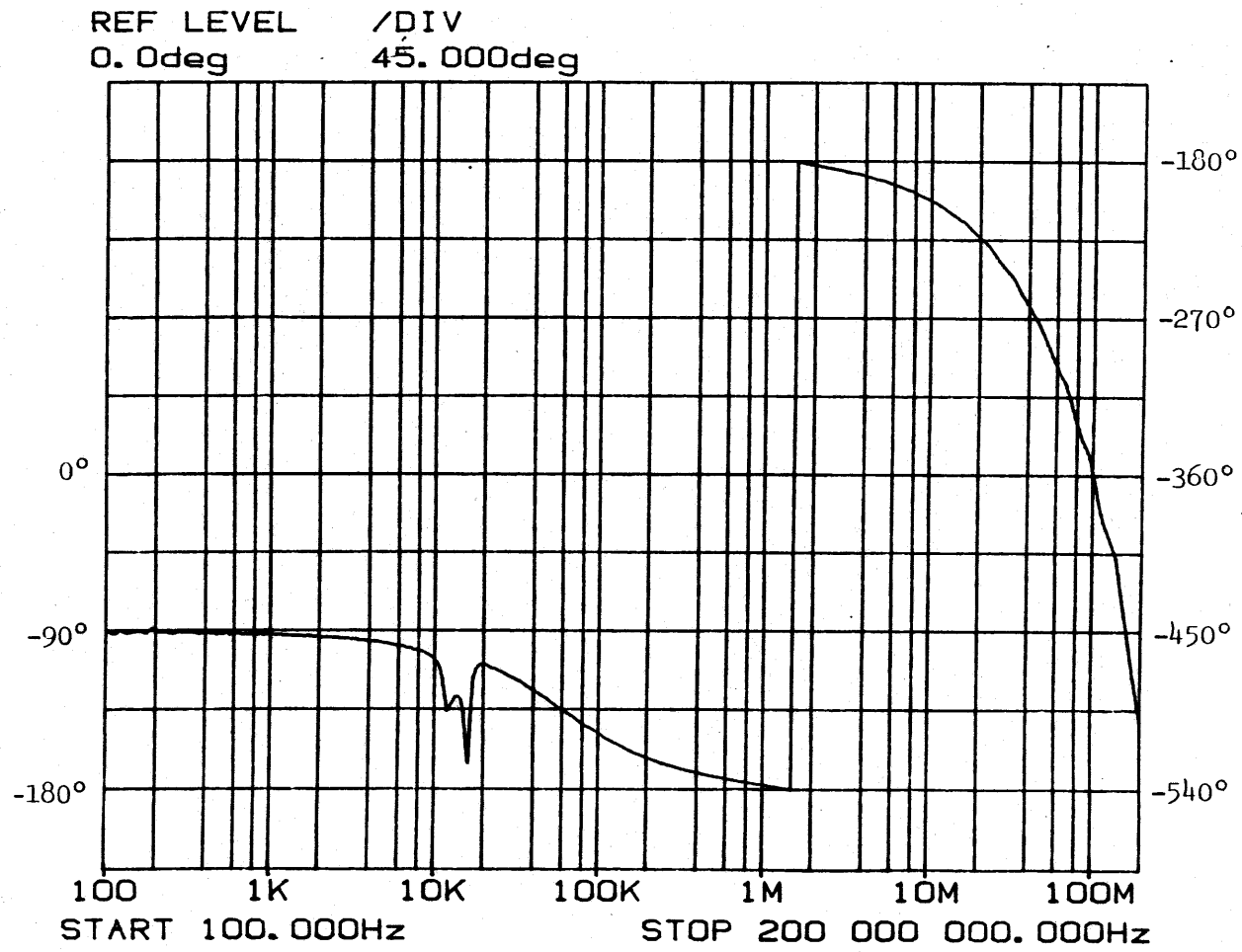

Figure 20. TCB-1A Inverting Output Phase

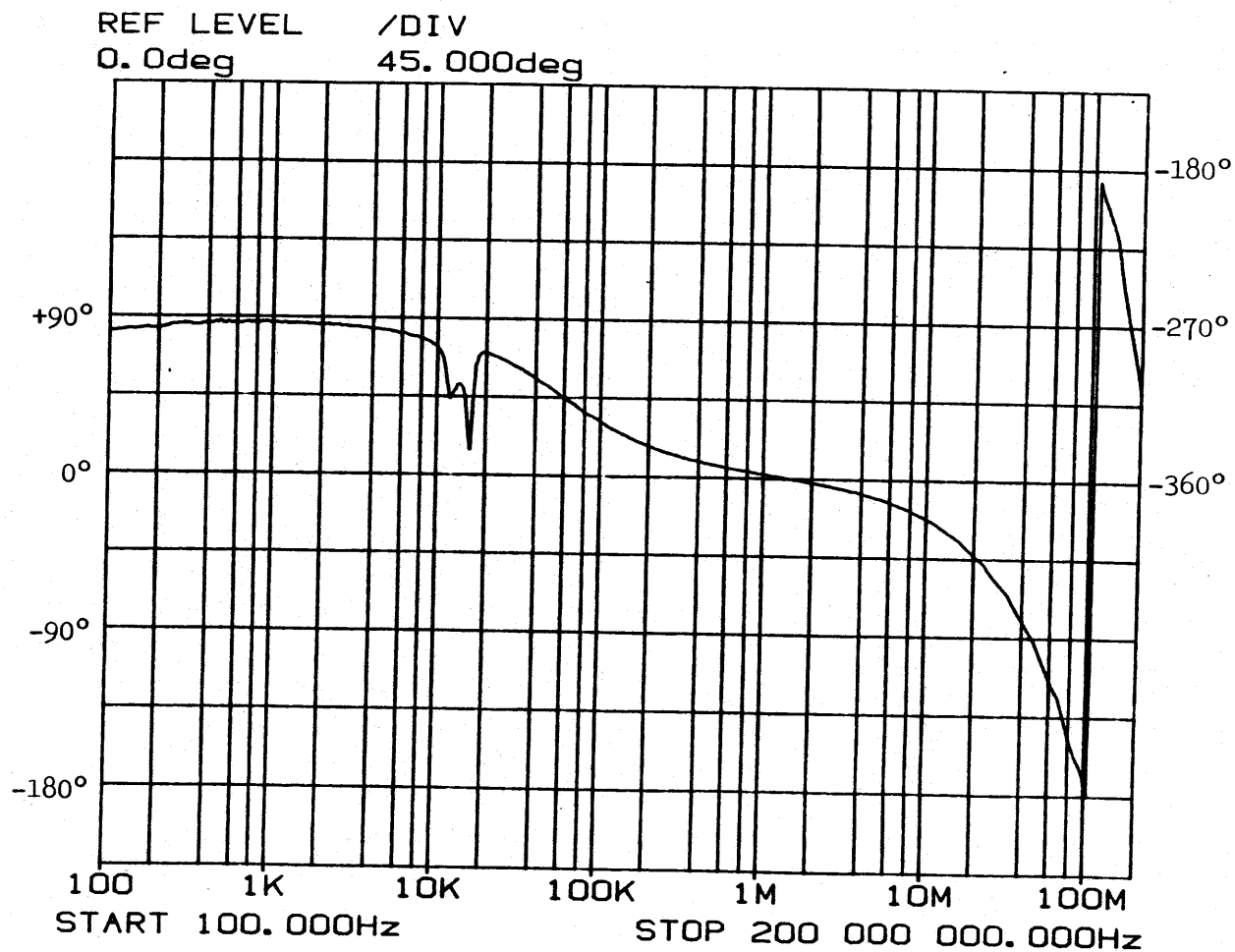

Figure 21. TCB-1A Non-Inverting Output Phase

V. CONCLUSIONS

The TCB-1A is an operational balun. The pertinent features of the TCB-1A are given in Table 1.

TABLE 1. LIST OF PERTINENT FEATURES OF THE TCB-1A

<u>PARAMETER</u>	<u>VALUE</u>
No. Turns	5 (each winding)
Input Impedance	50 ohms
Output Impedance	200 ohms (differential)
Pulse Rise Time	<2 ns
Insertion Loss	0.5 dB at 10 MHz
Low-Frequency Cutoff	100 kHz (-3 dB point)
High-Frequency Cutoff	>200 MHz (-3 dB point)
Band-pass Flatness	1 MHz to 100 MHz ( $\pm 1$ dB)
Common Mode Rejection	>40 dB, 10 kHz to 10 MHz
Across Band	>20 dB, 10 MHz to 100 MHz