

Mathematics Notes  
Note 72

November 1981

Enhancement of Poles in Spectral Analysis

Fung I. Tseng and Tapan K. Sarkar  
Department of Electrical Engineering  
Rochester Institute of Technology  
Rochester, New York 14623

## ABSTRACT

This paper presents a new technique for detecting a small pole in the presence of a nearby strong pole. By simultaneously applying the chirp z-transform (CZT) and a recently developed window, the new technique is shown to be able to detect and resolve a small pole.

The CZT is efficient since it employs the Fast Fourier Transform (FFT) to evaluate a convolution. But unlike the FFT which is limited to the evaluation of the spectrum on the  $j\omega$  axis, the CZT can evaluate the z-transform on the whole complex plane. And with the use of the new window, which is designed to have a near-sidelobe level of any specified value, the CZT is shown to be able to resolve two closely spaced poles with a large difference in amplitudes.

Unlike the Prony's method, the new technique does not require pre-determining the system order. No matrix inversion or solution of polynomial roots is required. Further, the new technique is a linear operation, thus even under noisy environments it yields accurate, stable results for extraction of poles from transient response data.

### I. Introduction

In target identification one often illuminates the target by a wideband pulse. One then characterizes the target by the complex natural resonances extracted from the electromagnetic response. This paper presents a new technique for detecting a small pole in the presence of a nearby strong pole.

In recent years the singularity expansion method has been applied to express the electromagnetic response in an expansion of complex resonances of the target [1]. It has been shown that the dominant complex natural resonances of a target are a minimal set of parameters

that define the overall physical properties of the target [2]. To extract the complex resonances the Prony's method has been applied successfully for noiseless data [3]. Recently, the pencil-of-function method has been shown to be effective in dealing with noisy data for extraction of the poles [4]. These techniques essentially involve nonlinear data processing, requiring the solution of polynomial roots and matrix inversion. The key problem is the determination of the system order [5], which is complicated due to the presence of noise in data.

To circumvent the complexity of these methods, an alternative technique for extracting the complex poles is investigated. By taking advantage of the simplicity and efficiency of the FFT algorithm, one can modify the FFT so that it can be employed to evaluate the z-transform of the time sequence along a general contour on the complex plane. The modified FFT or the chirp z-transform (CZT) therefore plays the role in a discrete system, played by the Laplace Transform in continuous systems. [6]. Because the time sequence is finite, the CZT has the leakage effect. To suppress the leakage effect, a recently developed window [7], which is designed to have a low near-sidelobe level, is simultaneously applied with the CZT. Two examples are given to illustrate the technique, which is shown to be able to detect and resolve a small pole in the presence of a nearby strong pole. The new technique does not require pre-determining the order of the system. No matrix inversion or solution of polynomial roots is required. Furthermore, since the CZT is a linear operation, it yields stable results even under noisy environments.

## II The Chirp z-Transform

Consider a M-pole system which is represented by the impulse response

$$x(t) = \sum_{m=1}^M a_m e^{\bar{s}_m t} \quad (1)$$

where  $\{\bar{s}_m\}$  are complex poles and  $\{a_m\}$  the corresponding residues. The system transfer function is then obtained by taking the Laplace Transform of  $x(t)$ , which yields

$$\bar{X}(s) = \sum_{m=1}^M \frac{a_m}{s - \bar{s}_m} \quad (2)$$

If  $x(t)$  is uniformly sampled at  $t_n = nT$ ,  $n=0,1,\dots,N-1$ , then, instead of the Laplace Transform, the z-transform is applied:

$$X(z) = \sum_{n=0}^{N-1} x_n z^{-n} \quad (3)$$

where  $x_n = x(t_n)$  and  $z = e^{st}$ . The z-transform of  $\{x_n\}$  is representative of the Laplace transform of  $x(t)$ . From Eq. (2) it is seen that  $\bar{X}(s)$  has singularity at the poles  $\{\bar{s}_m\}$ . Similarly, the z-transform  $X(z)$  tends to have peak values at  $z_m = e^{\bar{s}_m T}$ . Thus by evaluating  $X(z)$  along a contour near the poles one can estimate the pole locations. If  $X(z)$  is evaluated at the set of equally spaced points around the unit circle,  $z_k = e^{-j2\pi k/N}$ ,  $k=0, 1, 2, \dots, N-1$ , it results in a discrete Fourier Transform (DFT):

$$X(z_k) = \sum_{n=0}^{N-1} x_n e^{-j2\pi nk/N} \quad k=0, 1, \dots, N-1 \quad (4)$$

By employing the FFT algorithm,  $X(z_k)$  can be computed efficiently. To achieve this efficiency,  $N$  is required to be a highly composite number. If one is to employ a power-of-2 FFT algorithm, this can be accomplished by augmenting the  $N$ -point sequences  $\{x_n\}$  with a sufficient number of zeros so that their total length is a power of 2.

The DFT is effective in locating the poles only if the poles are on or near the  $j\omega$  axis. In order to locate a pole which is away from the  $j\omega$  axis, one would need to compute the z-transform along a general contour. There are two general approaches to this problem: (a) the contour is a circle that is concentric with the unit circle, and (b) the contour is a spiral. The former is called modified FFT and the latter is called chirp z-transform (CZT)

(A) Modified FFT

A concentric circle on the z-plane is equivalent to a straight line on the s-plane. The correspondence is shown in Figure 1. Let  $\{s_k\}$  and  $\{z_k\}$  be the corresponding points on the s-plane and z-plane, respectively. Let  $f_s = 1/T$  be the sampling frequency. Then  $s_k = \sigma_0 + j\omega_k$ , where  $\omega_k = 2\pi k f_s / N$ . The  $\{z_k\}$  are then given by

$$z_k = e^{\sigma_0 T} e^{j2\pi k/N} \quad k=0, 1, 2, \dots, N-1. \quad (5)$$

where  $|z_k| = e^{\sigma_0 T}$  is the radius of the circle. Eq. (4) can now be written as

$$X(z_k) = \sum_{n=0}^{N-1} (x_n e^{-n\sigma_0 T}) e^{-j2\pi nk/N} \quad (6)$$

Eq. (6) shows that, to evaluate  $X(z)$  along the contour  $|z| = e^{\sigma_0 T}$  on the z-plane or along the straight vertical line  $\sigma = \sigma_0$  on the s-plane, one can multiply the sequence  $\{x_n\}$  by  $\{e^{-n\sigma_0 T}\}$  and then take the FFT. If one is interested in obtaining frequency samples equally spaced over a small portion of the unit circle, one may augment the original sequence with zeros, take the FFT, and retain the frequency samples of interest. For example, if, instead of the frequency spacing  $F = 1/NT$ , one desires to have a smaller spacing  $F' = 1/LT$ , one has to augment  $L-N$  zeros to

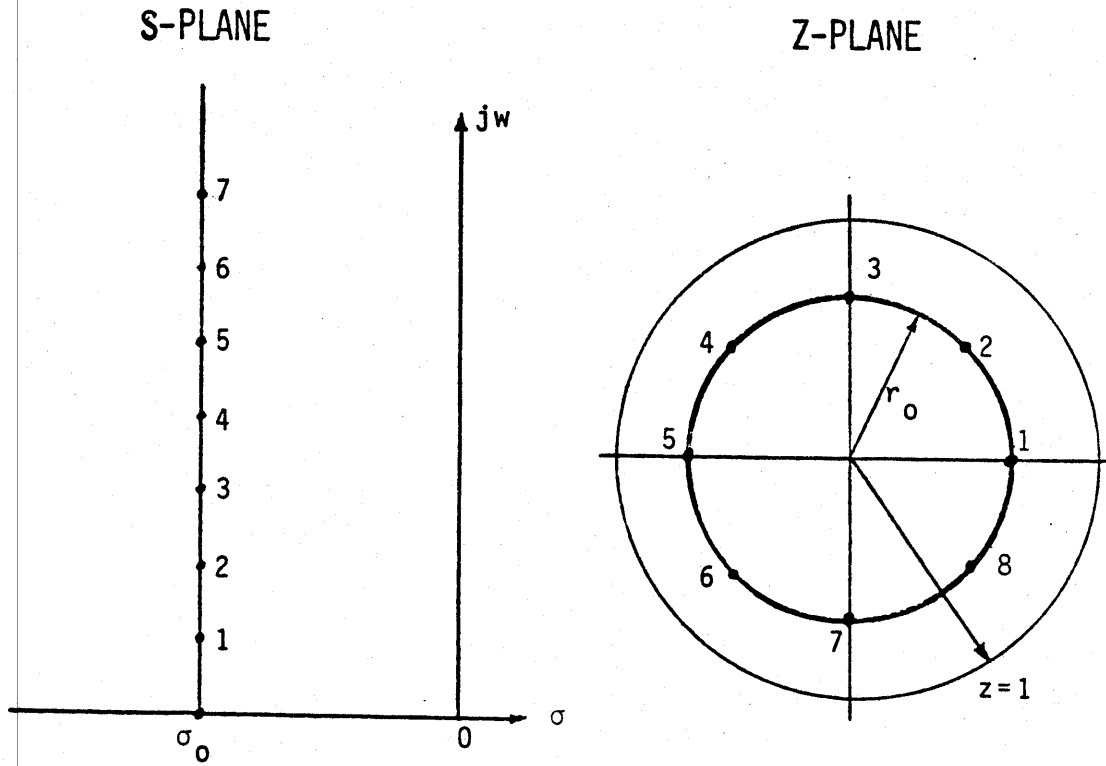

Fig. 1. The correspondence of a z-plane contour to an s-plane contour ( $z=e^{st}$ ,  $r_0=e^{\sigma_0 T}$ ).

$x_n$ . Namely, let

$$\hat{x}_n = \begin{cases} x_n & n=0, 1, \dots, N-1 \\ 0 & n=N, N+1, \dots, L-1 \end{cases} \quad (7)$$

and then evaluate the following equations by the FFT.

$$X(z_k) = \sum_{n=0}^{L-1} (\hat{x}_n \sigma^{-\sigma_0 n T}) e^{j2\pi kn/L} \quad k=0, 1, 2, \dots, L-1. \quad (8)$$

From the  $L$  frequency samples one then retains only the desired spectral points.

(B) CZT

To evaluate Eq. (3) along the contour as shown in Fig. 2, let

$$s_k = s_0 + k\Delta s \quad k=0, 1, \dots, J-1 \quad (9)$$

where  $\Delta s = \Delta\sigma + j\Delta\omega$ ,  $\Delta\sigma$  is the increment along  $\sigma$ -axis and  $\Delta\omega$  is the increment along the  $j\omega$ -axis. In the  $z$ -plane, the contour is a spiral given by

$$z_k = e^{s_0 T} e^{k\Delta s T} \quad k=0, 1, \dots, J-1 \quad (10)$$

which has a radius of  $|z_k| = e^{(\sigma_0 + k\Delta\sigma)T}$  and a uniform angle of increment  $\Delta\theta = T\Delta\omega$ . Eq. (3) can now be written as

$$X(z_k) = \sum_{n=0}^{N-1} x_n e^{-ns_0 T} e^{-nkT\Delta s} \quad k=0, 1, \dots, J-1 \quad (11)$$

By using the Bluestein's identity

$$nk = \frac{1}{2}[n^2 + k^2 - (k-n)^2] \quad (12)$$

one can write Eq. (11) as

$$X(z_k) = e^{-k^2 T\Delta s/2} \sum_{n=0}^{N-1} g_n h_{k-n} \quad (13)$$

$$\text{where } g_n = x_n e^{-ns_0 T} e^{-n^2 T\Delta s/2} \quad (14)$$

and

$$h_n = e^{-n^2 T\Delta s/2} \quad (15)$$

Eq. (13) shows that the CZT can be evaluated by high-speed convolution with the use of the FFT algorithm.

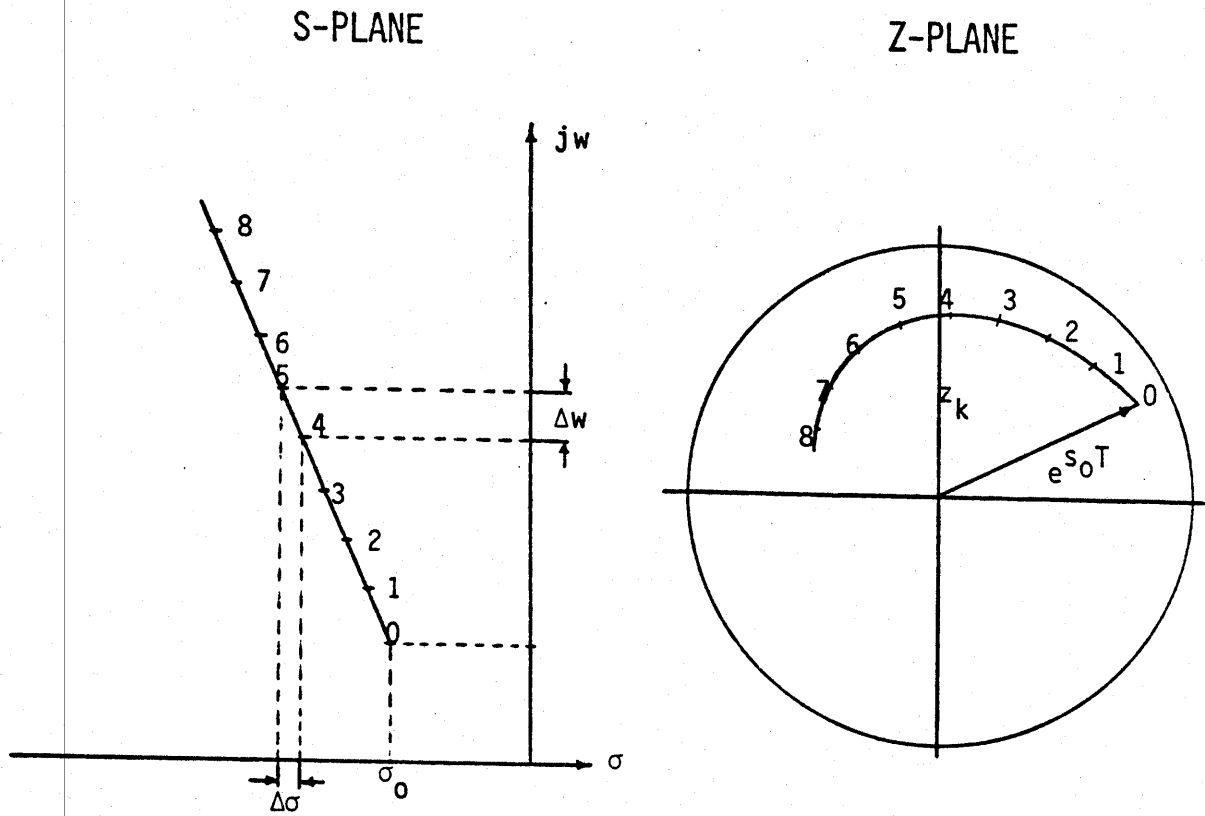

Fig. 2. The correspondence of a z-plane contour to an s-plane contour for the CZT.



### III The Tseng Window

Since the data sequence is finite, both the modified FFT and CZT suffer from the leakage effects. The main impediment of the leakage effects is the high near-sidelobes of the spectral window. In detecting a small pole in the presence of nearby strong poles on the  $j\omega$  axis, the Tseng window has been shown to be effective [7]. Thus a special Tseng window designed to have low near-sidelobes will be employed to improve the detectability of the CZT.

Consider a data window specified by a set of  $2K$  weights  $\{w_0, w_1, w_2, \dots, w_{2K-1}\}$ . The spectral window is related to the data window by the Fourier Transform:

$$W(f) = \sum_{k=0}^{2K-1} w_k e^{-j2\pi f k T} \quad (16)$$

By assuming that the data window is real and even, Eq. (16) can be written as

$$W(f) = 2e^{-j(2K-1)\pi f T} \prod_{k=1}^{K-1} (x^2 - \gamma_k^2) \quad (17)$$

$x = \cos \pi f T$

where  $\{\gamma_k\}$  are the zeros of the polynomial. By controlling the locations of the zeros one can form a spectral window with a desired sidelobe structure. To suppress near-sidelobes the zeros  $\{\gamma_k\}$  can be chosen as follows:

$$\gamma_k = \cos\left(\frac{\pi}{2K} z_k\right) \quad k=1, 2, \dots, K-1 \quad (18)$$

where

$$z_k = k \quad \text{for } k \geq k_0 \quad (19)$$

and

$$z_{k-1} = z_k - \Delta_k \quad \text{for } 1 \leq k \leq k_0 \quad (20)$$

with

$$\Delta_k = 1 - A \sin \left[ \left( \frac{k_0 - k}{k_0 - 1} \right) \frac{\pi}{2} \right] \quad (21)$$

In Eqs. (20) and (21),  $\Delta_k$  is the increment of  $\{z_k\}$ ,  $k_0$  is the number of the near-sidelobes to be suppressed, and  $A$  is a parameter to control the near-sidelobe level ( $A \leq 1$ ). The design principle is based on the observation that to suppress the first  $k_0$  sidelobes the zeros  $\{\gamma_k\}$  should have small spacings, which is achieved by making the increments  $\{\Delta_k\}$  small. The smallest increment occurs at  $k=1$  and is given by  $\Delta_1 = 1 - A$ . By increasing  $A$  and/or  $k_0$  the near-sidelobe level can be reduced to any desired value.

A Tseng window is designed to suppress the near-sidelobes for 128 uniformly sampled weightings. The chosen parameters are:  $k_0=4$  and  $A=0.7$ . Fig. 3 shows the rectangular and the Tseng windows. The rectangular window is obtained by setting  $A=0$ . It is seen that as  $A$  is increased from 0 to 0.7 the near-sidelobes are effectively reduced from -13dB to -47dB.

#### IV. Enhancement of Poles

The chirp z-transform algorithm and the Tseng window are now applied to a four-pole system. Attention is focused on the resolvability of two closely spaced poles which have large amplitude differences. The impulse response of the four-pole system is represented by Eq. (1) with the following parameters:

$$a_1=0.1, \quad \sigma_1=-250\text{Hz}, \quad f_1=1000\text{Hz}$$

$$a_2=1.0, \quad \sigma_2=-300\text{Hz}, \quad f_2=1250\text{Hz}$$

$$a_3=1.0, \quad \sigma_3=-150\text{Hz}, \quad f_3=2000\text{Hz}$$

$$a_4=0.1, \quad \sigma_4=-200\text{Hz}, \quad f_4=2250\text{Hz}$$

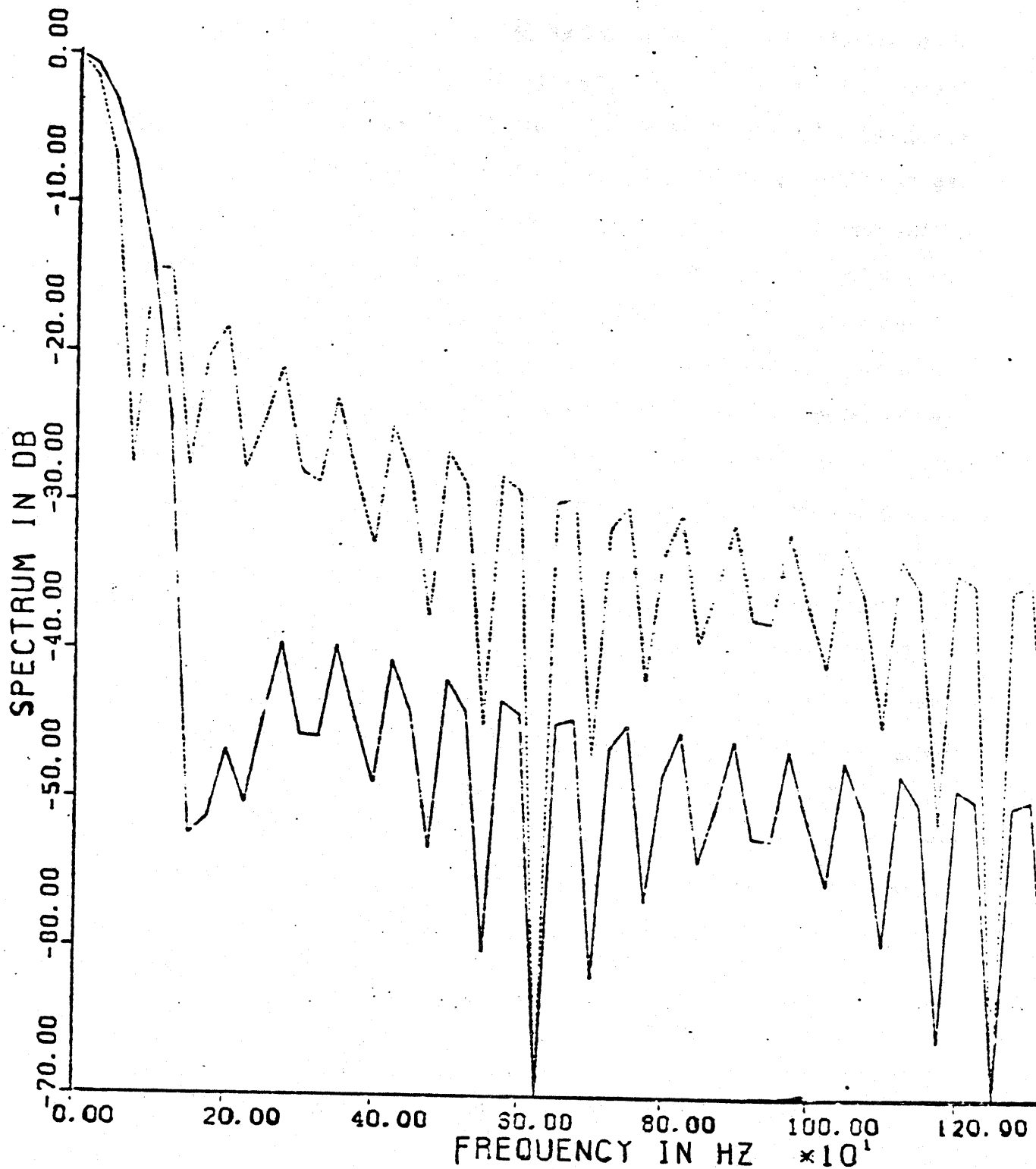

Fig. 3. The spectral windows of the rectangular (dash) and the Tseng (solid) weightings.

The sampling frequency is chosen as 10kHz. There are 128 samples. These samples are weighted by 128 weightings of the Tseng data window. The chirp z-transform of these samples was then evaluated along eight contours, which are shown in Fig. 4 along with the s-plane pole location. The first contour is on the  $j\omega$  axis; this is the regular FFT. The rest of the contours are parallel to the  $j\omega$  axis with  $\sigma_0 = -50, -100, -150, -200, -250, -300$  and  $-350$  Hz, respectively. These are called modified FFT and are special cases of CZT. The spectra of the four-pole system along these contours are presented in Figs. 5 through 12. Both the spectra using the rectangular and the Tseng windows, respectively, are shown for comparison. Fig. 5 (for  $\sigma_0 = 0$ ) shows that the FFT can detect the frequencies at  $f_2$  (1250 Hz) and  $f_3$  (2000 Hz) only. Both windows fail to detect the two small poles at  $f_1$  (1000 Hz) and  $f_4$  (2250 Hz). As the contour moves to  $\sigma_0 = -50$  Hz Fig. 6 indicates that, even though the Tseng window shows sharper resolution, both windows still could not detect the two small poles. As the contour is moved further to the left at  $\sigma_0 = -100$  Hz, Fig. 7 shows a deep valley between  $f_2$  (1250 Hz) and  $f_3$  (2000 Hz). The Tseng window shows a small peak at  $f_4$  (2250 Hz) but the rectangular window still could not detect the two small poles. Now as the contour is moved to  $\sigma_0 = -150$  Hz, which passes right through the pole at  $f_3$  (2000 Hz), the Tseng window can now clearly detect and resolve the pole at  $f_4$  ( $\sigma_4 = -200$  Hz and  $f_4 = 2250$  Hz), as shown in Fig. 8. In order to detect the small pole at  $f_1 = 1000$  Hz the contour is moved further to the left at  $\sigma_0 = -200$  Hz. The Tseng window now starts indicating the pole at  $f_1$  ( $\sigma_1 = -250$  Hz) (see Fig. 9). By further moving the contour to the left at  $\sigma_0 = -250$  Hz, which passes through the pole at  $f_1$ , the results in Fig. 10 indicate that the Tseng window can detect all the poles while the

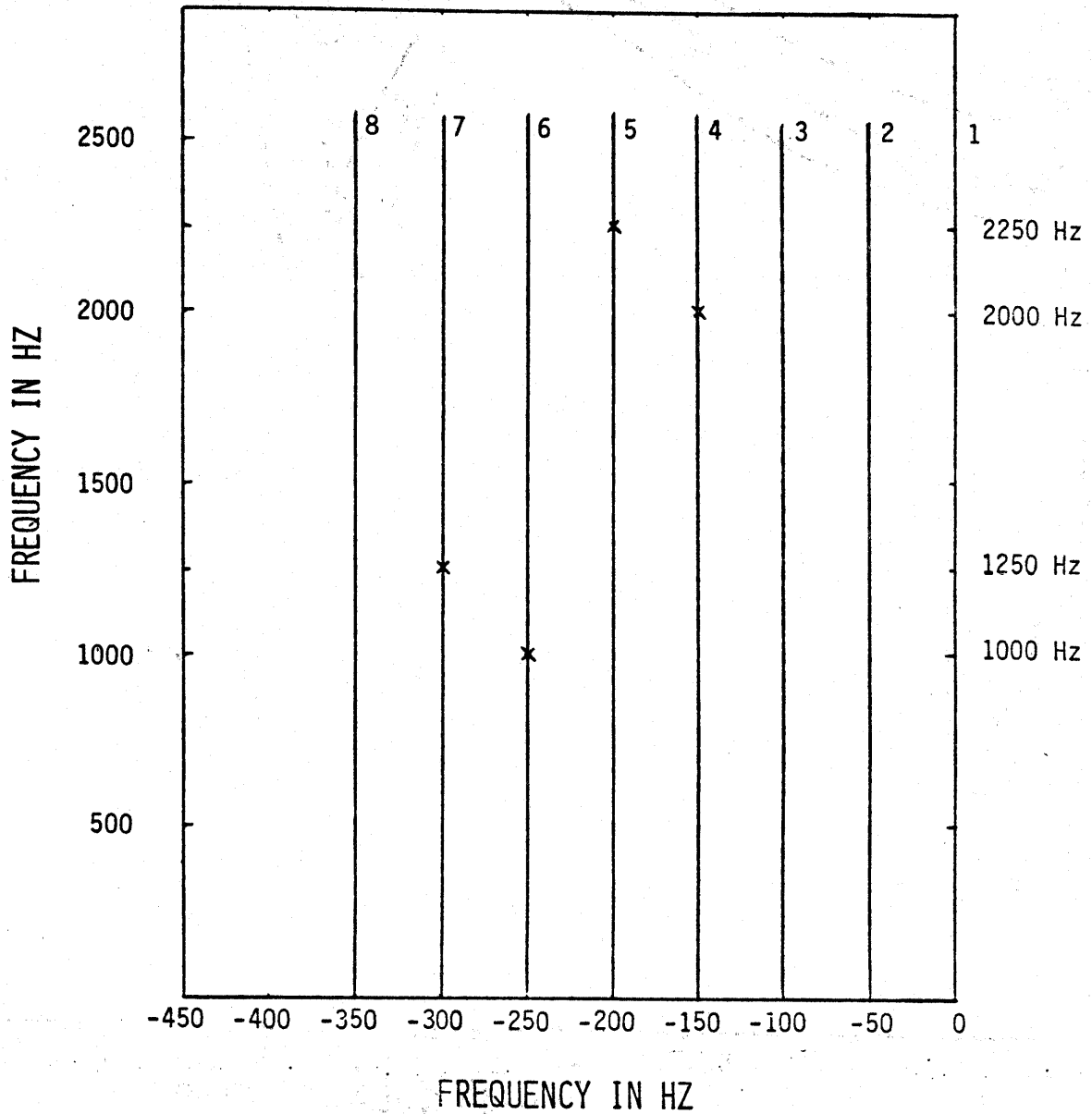

Fig. 4. The s-plane locations of the poles and the eight contours for evaluation of the modified FFT.

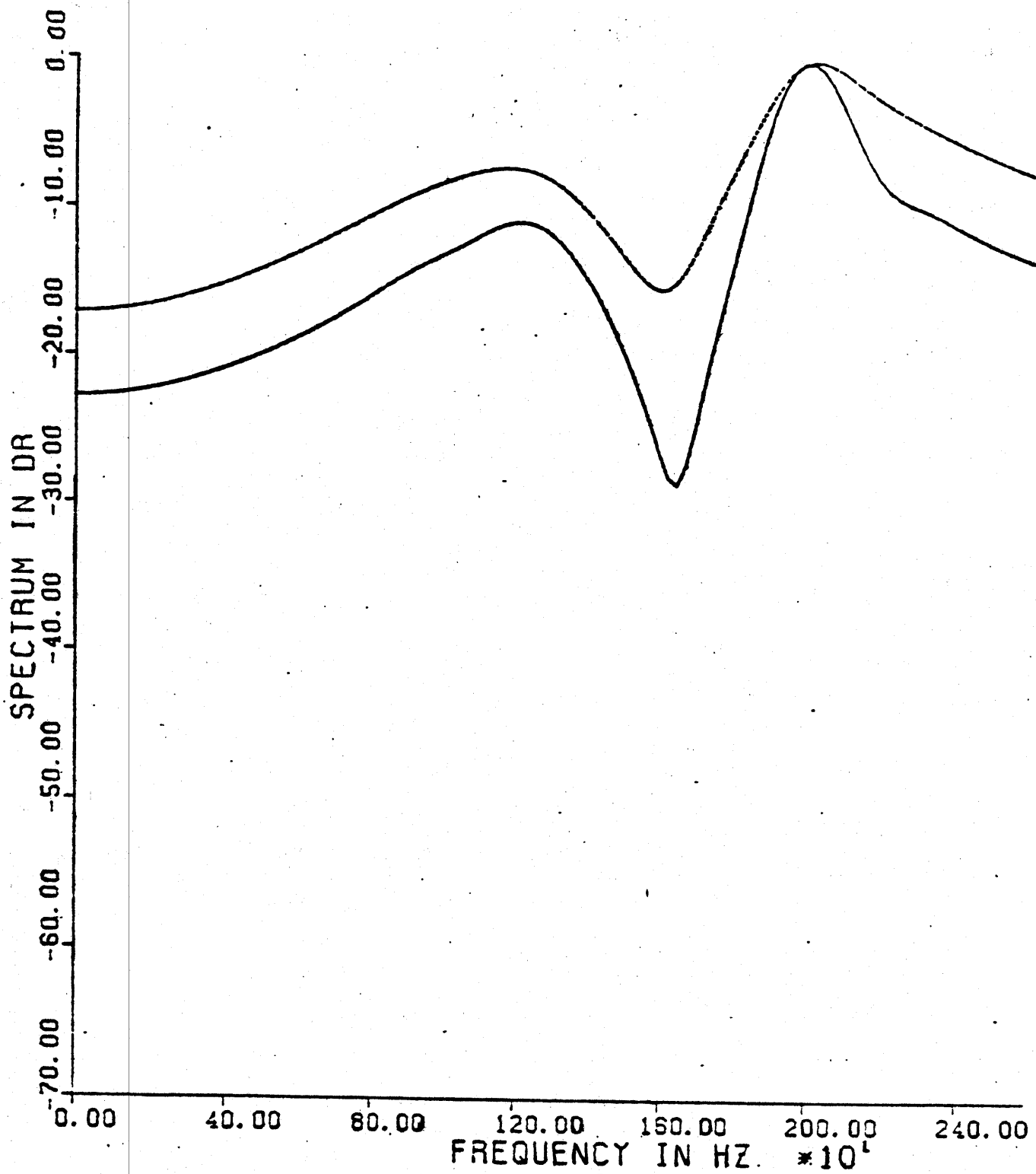

Fig. 5. Detection of a four-pole signal by FFT with the rectangular (dash) and the Tseng (solid) windows ( $\sigma_0=0$ )

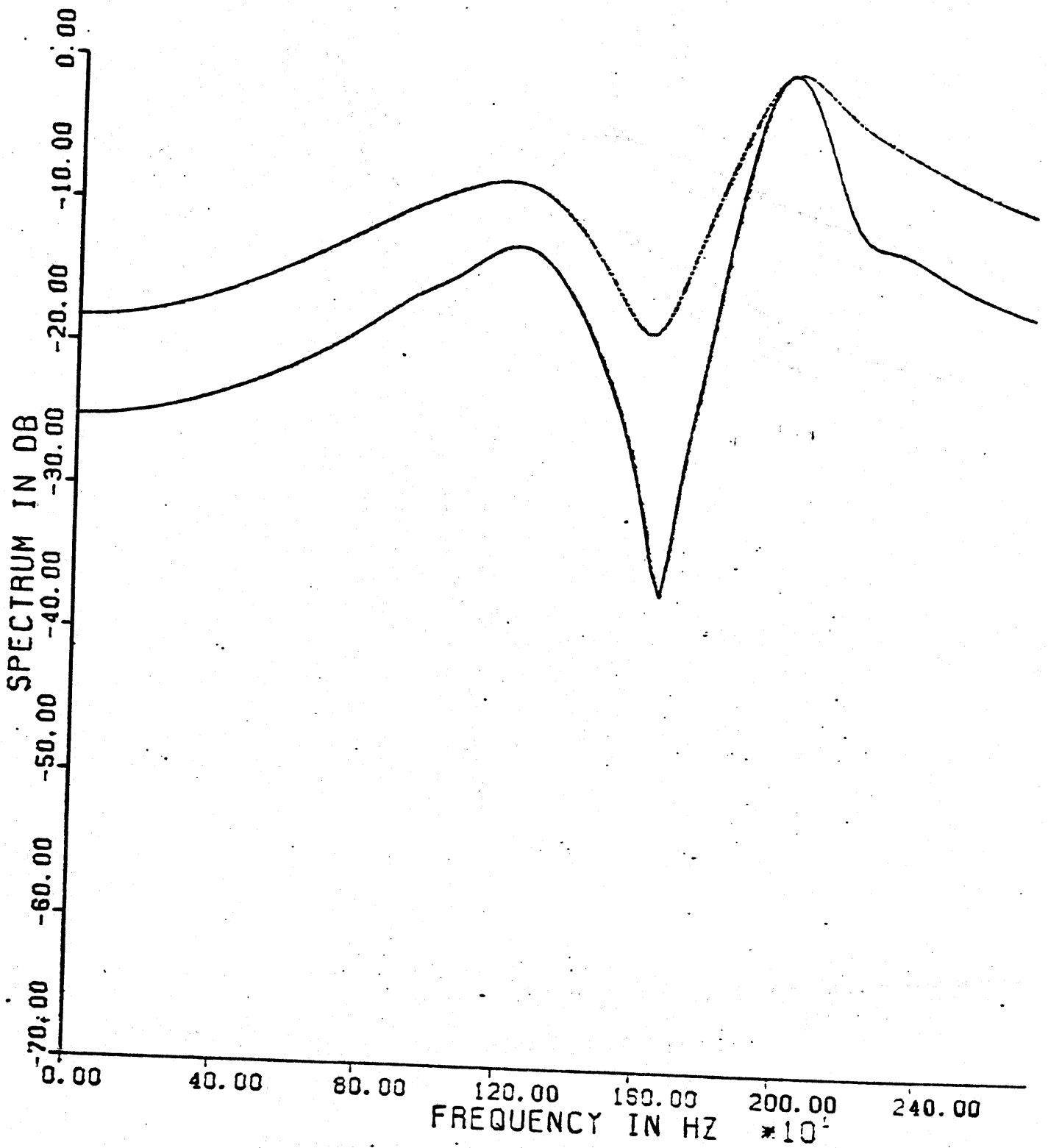

Fig. 6. Detection of a four-pole signal by modified FFT with the rectangular (dash) and the Tseng (solid) windows ( $\sigma_0 = -50\text{Hz}$ )

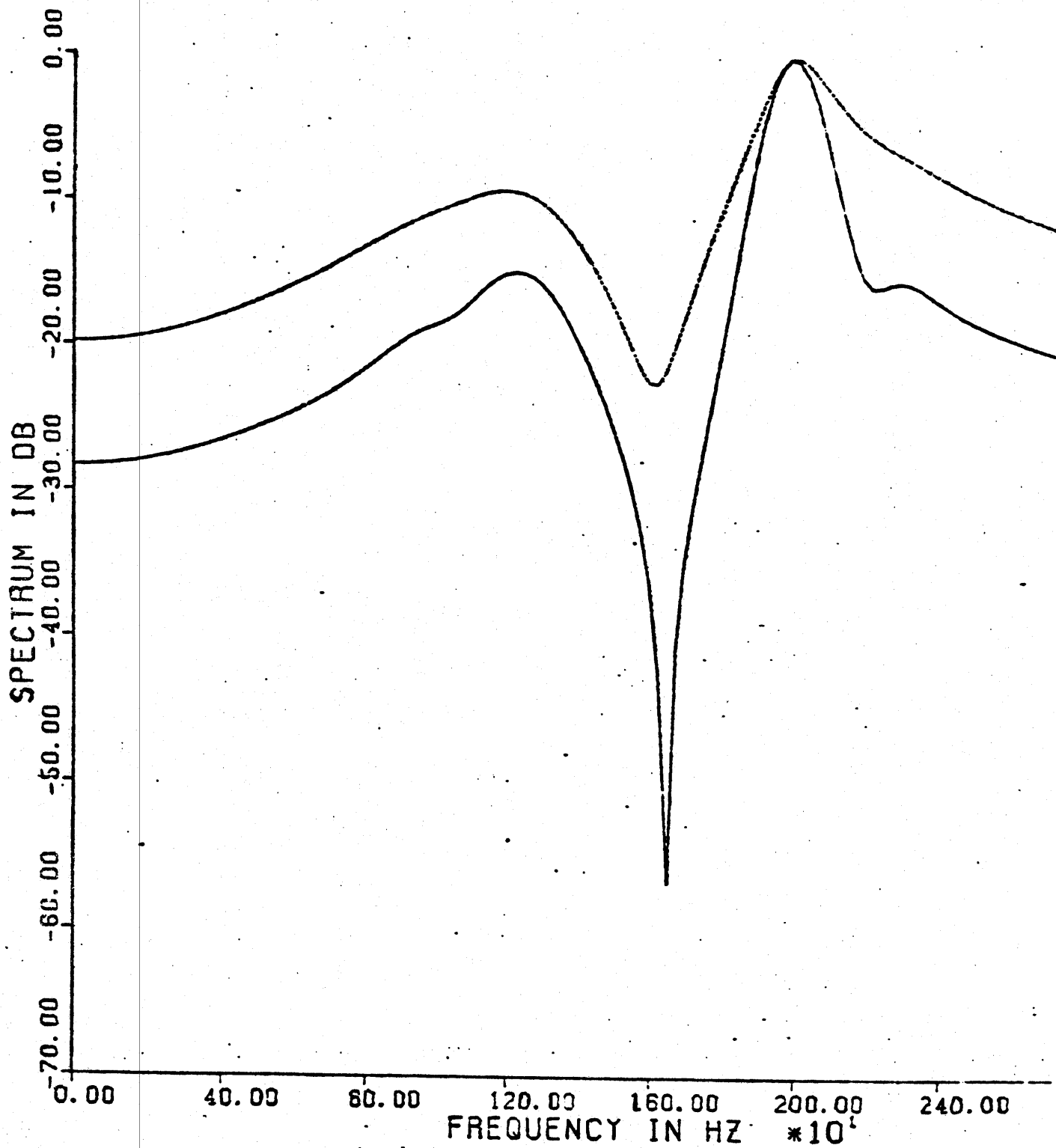

Fig. 7. Detection of a four-pole signal by modified FFT with the rectangular (dash) and Tseng (solid) windows. ( $\sigma_0 = -100\text{Hz}$ ).



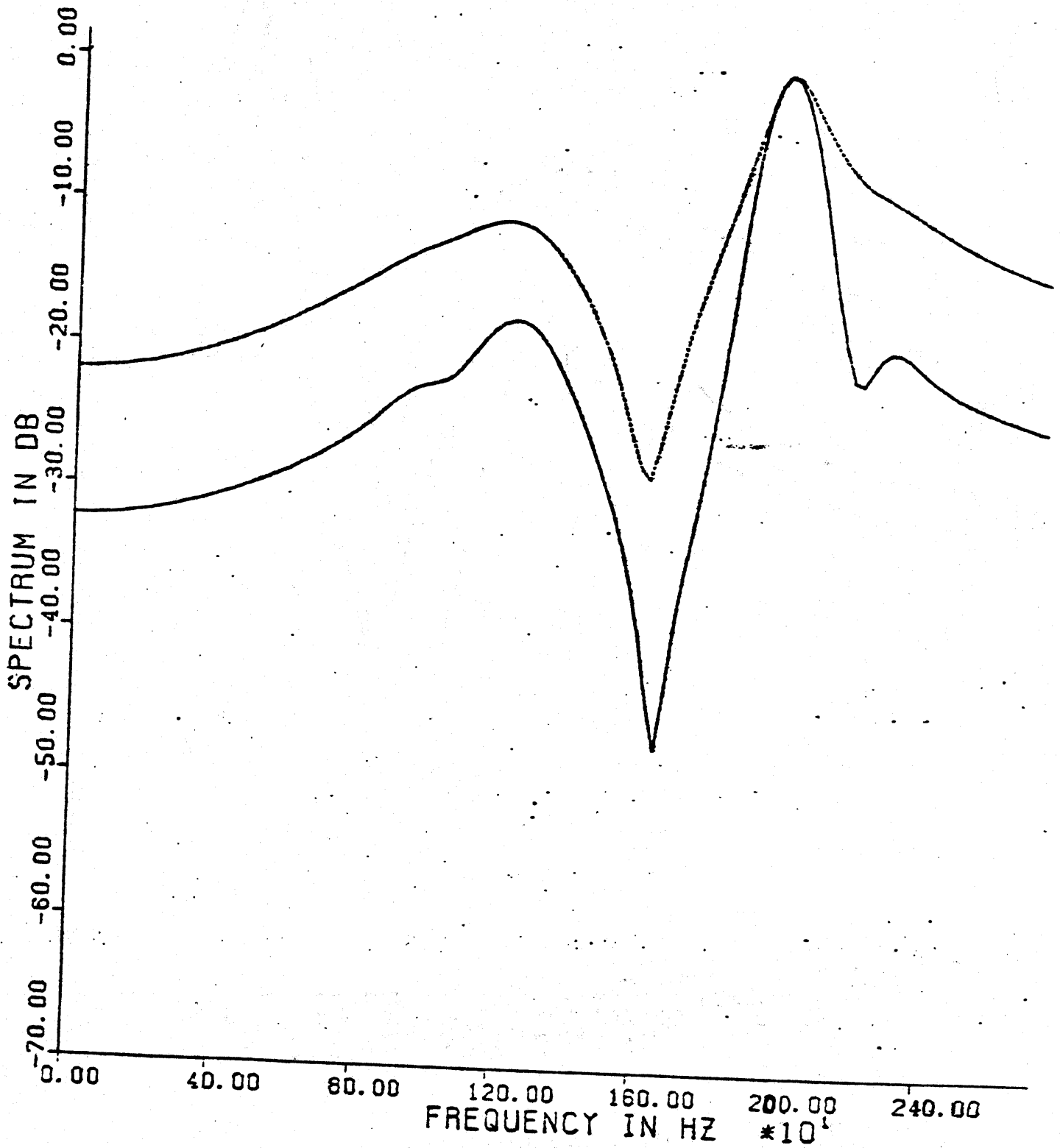

Fig. 8. Detection of a four-pole signal by modified FFT with the rectangular (dash) and Tseng (solid) windows. ( $\sigma_0 = -150\text{Hz}$ ).

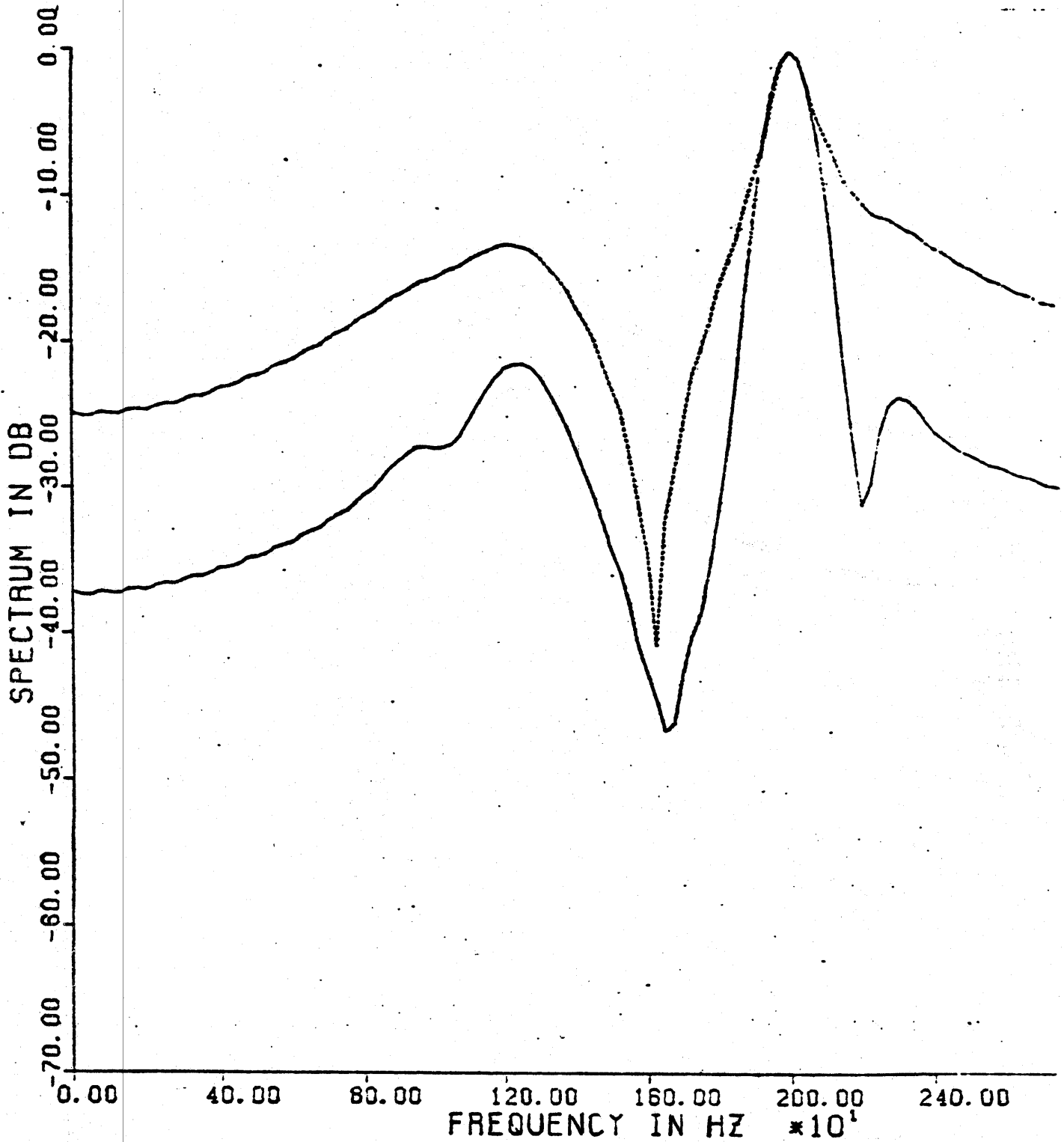

Fig. 9. Detection of a four-pole signal by modified FFT with the rectangular (dash) and Tseng (solid) windows ( $\sigma_0 = -200\text{Hz}$ ).

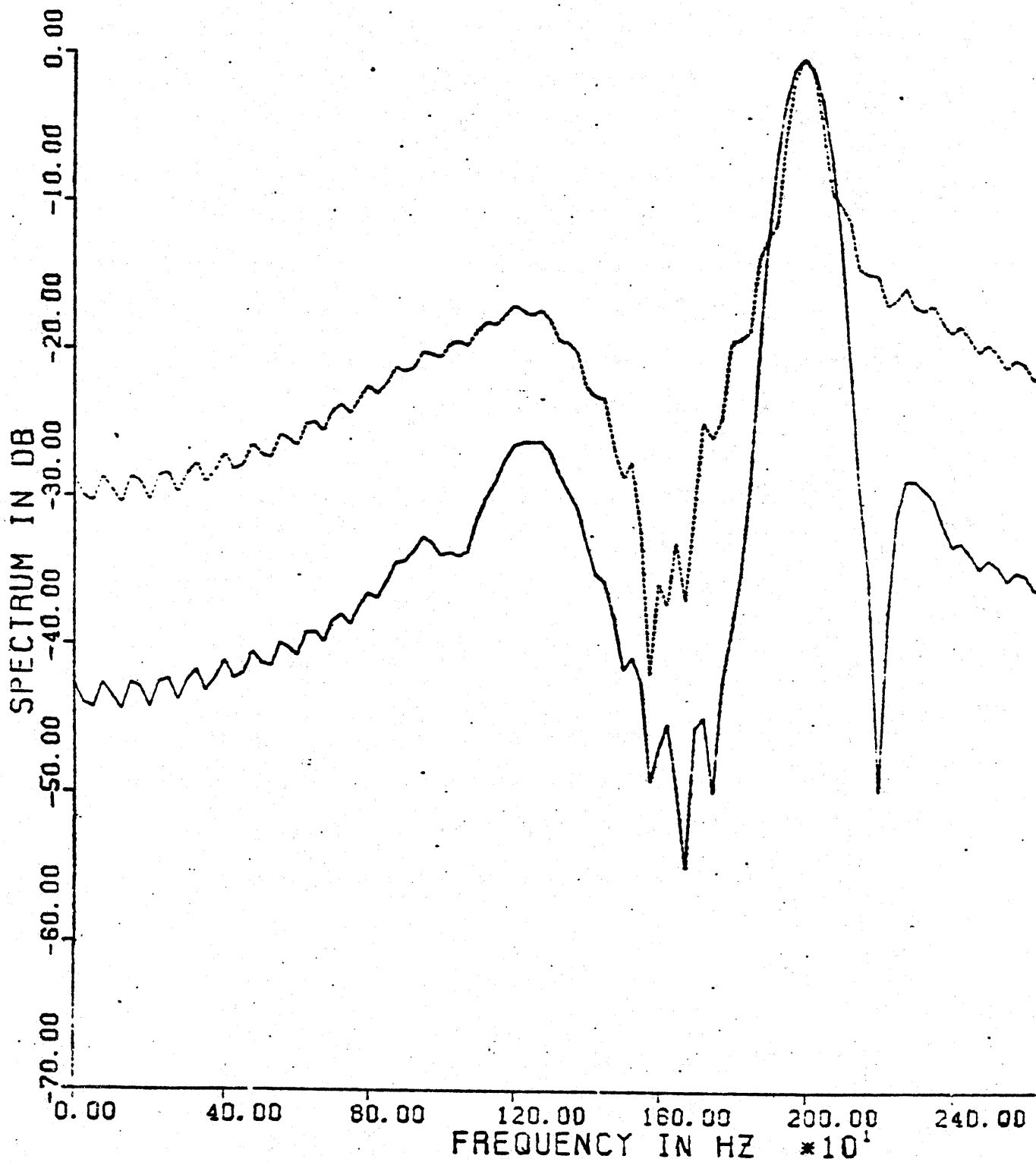

Fig. 10. Detection of a four-pole signal by modified FFT with the rectangular (dash) and Tseng (solid) windows. ( $\sigma_0 = -250\text{Hz}$ ).

rectangular window still can not detect the two small poles. As the contours are pushed further to the left,  $\sigma_0 = -300$  Hz and  $\sigma_0 = -350$  Hz in Fig. 11 and 12 respectively, the resolution at each pole becomes sharper, the peaks at  $f_1$ ,  $f_2$  and  $f_4$ , however, suffer from splitting. This is due to the computation noise as seen from Eq. (6) where  $x_n$  is multiplied by  $e^{-n\sigma_0 T}$  which can become very large when  $-n\sigma_0$  becomes large. From these spectra it appears that the best contour is the one at  $\sigma_0 = -250$  Hz, which lies closest to the smallest pole at  $f_1$ . In all these examples the rectangular window never detected the two small poles, while by properly choosing the contour the Tseng window is capable of detecting the two small poles.

In the next example, instead of the modified FFT, the regular CZT is applied to the samples along four tilted contours. Fig 13 shows the s-plane pole locations and the four contours on the s-plane. For each contour the rectangular and the Tseng windows are applied separately. The results are presented in Figs. 14 through 17. Fig. 14 shows the spectra along the contour  $\Delta\sigma=1$ . It is seen that the Tseng window shows sharper resolution. Both windows could detect the larger poles at  $f_2$  (1250 Hz) and  $f_3$  (2000 Hz) but both failed to detect the small poles. As the contour is tilted more to  $\Delta\sigma=2$ , which passes between the poles at  $f_3$  and  $f_4$ , the CZT results show that the Tseng window has better resolution (see Fig. 15): The pole at  $f_4$  is clearly resolved. But the rectangular window again fails to detect the two small poles. In order to detect the small pole at  $f_1$  (1000 Hz) the contour is further tilted to  $\Delta\sigma=3$ . The results are presented in Fig. 16. The resolution of the Tseng window is now very sharp at  $f_3$  and  $f_4$  (2250 Hz) but failed to detect the small pole at  $f_1$ . Instead, the high frequency noise starts

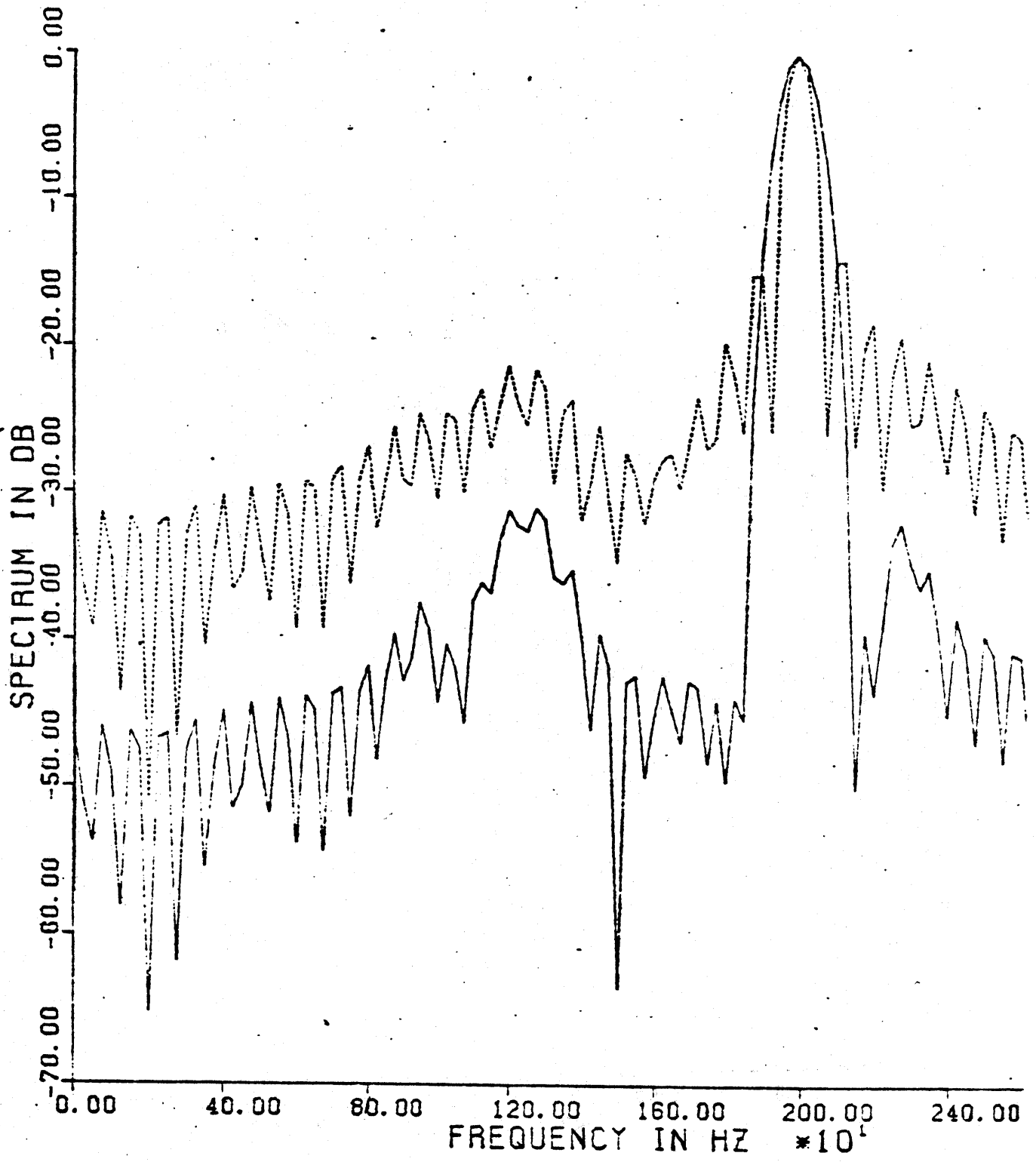

Fig.11. Detection of a four-pole signal my modified FFT with the rectangular (dash) and Tseng (solid) windows ( $\sigma_0 = -300\text{Hz}$ ).

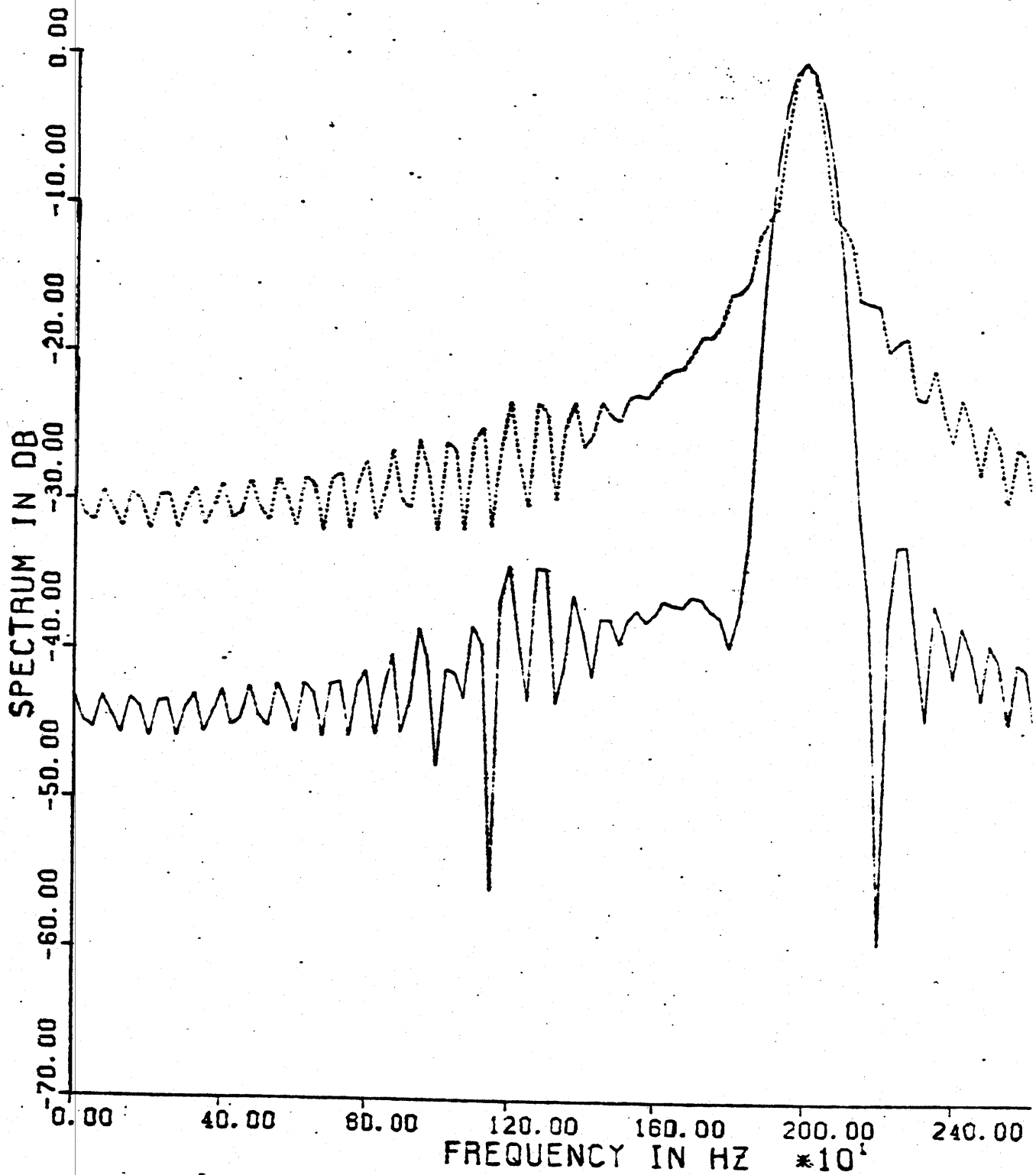

Fig. 12. Detection of a four-pole signal by modified FFT with the rectangular (dash) and Tseng (solid) windows ( $\sigma_0 = -350\text{Hz}$ ).

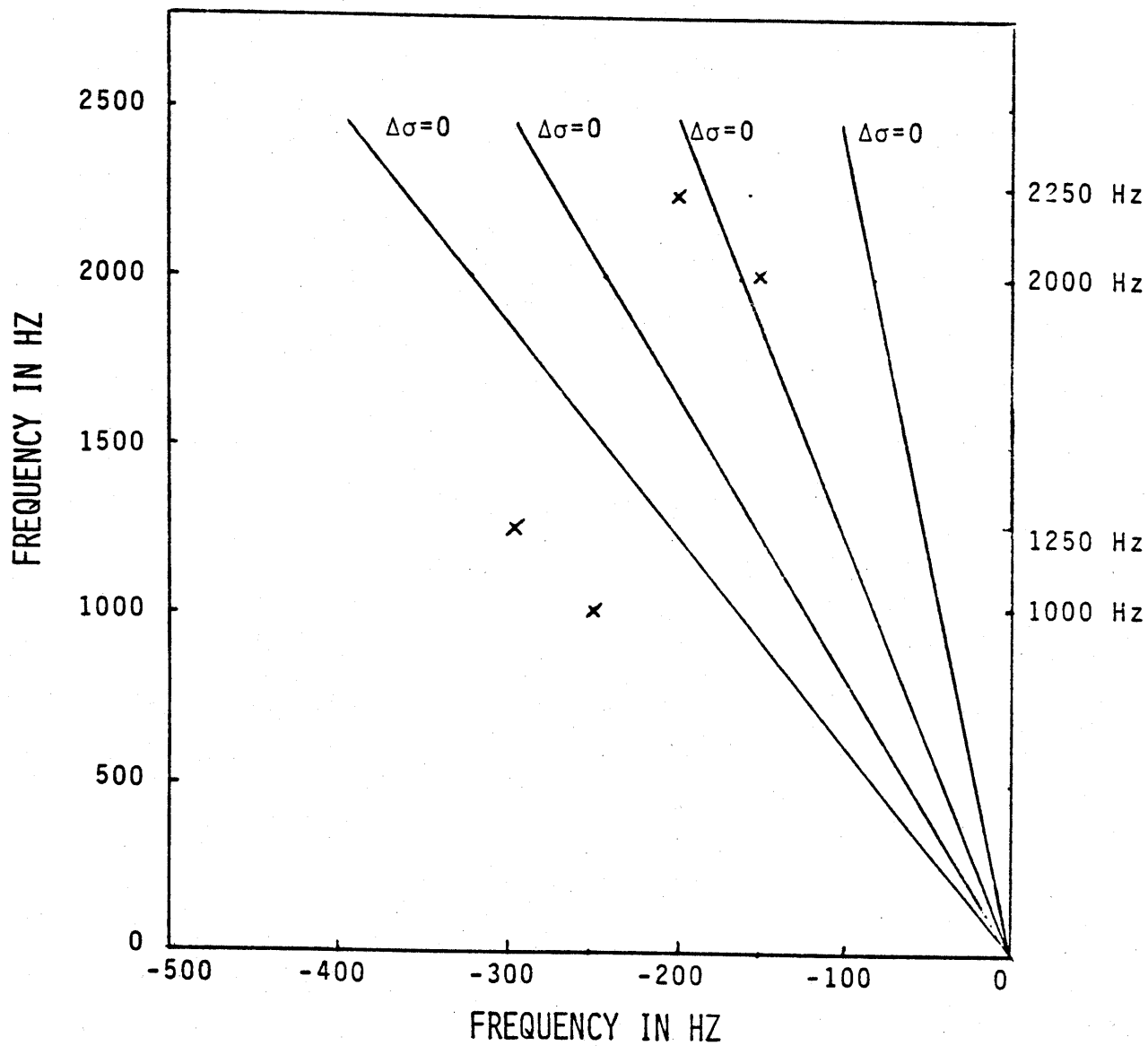

Fig.13. The s-plane locations of the poles and the four contours for evaluation of the CZT.

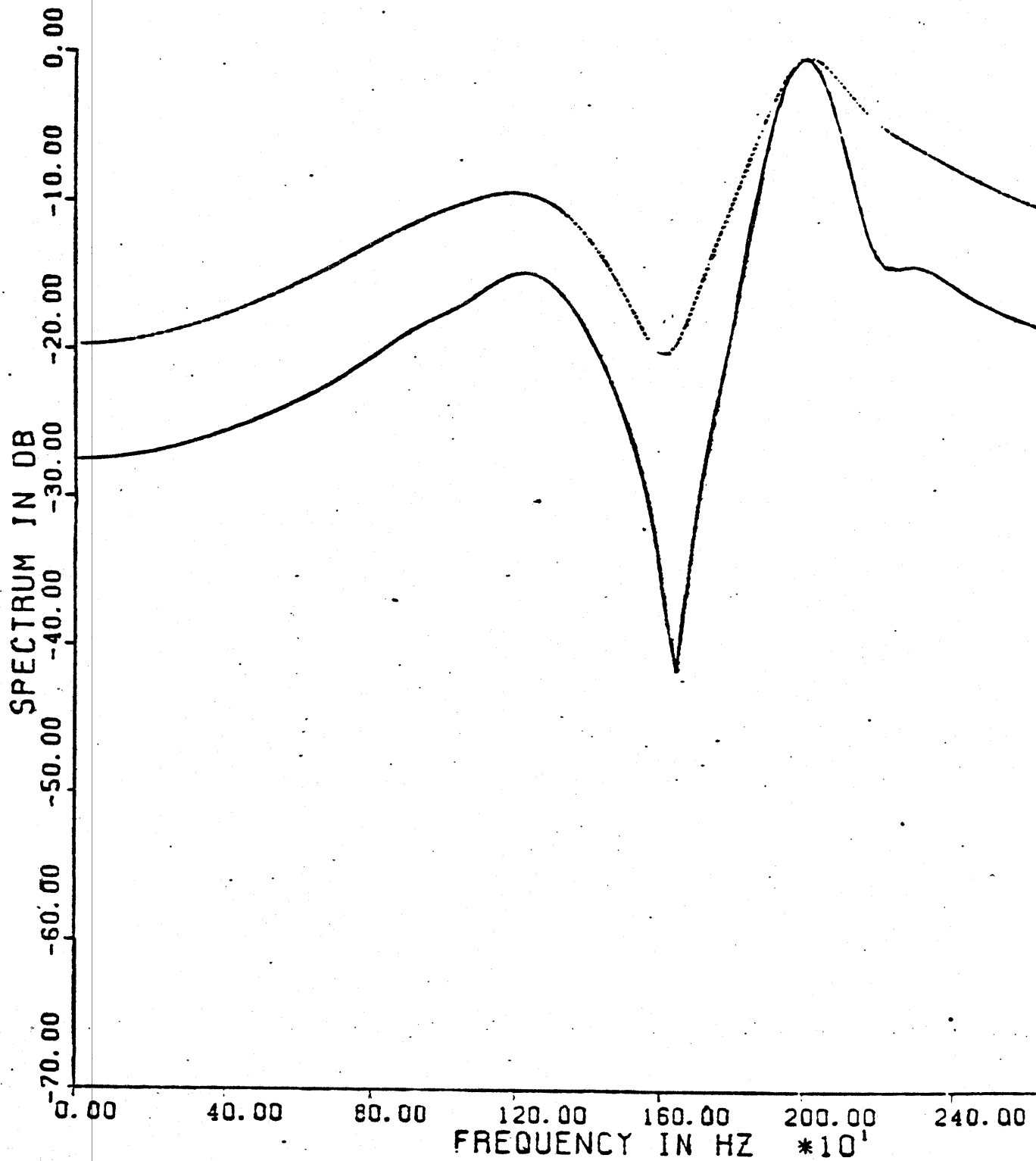

Fig. 14. Detection of a four-pole signal by the CZT with the rectangular (dash) and Tseng (solid) windows ( $\Delta\sigma=1$ ).



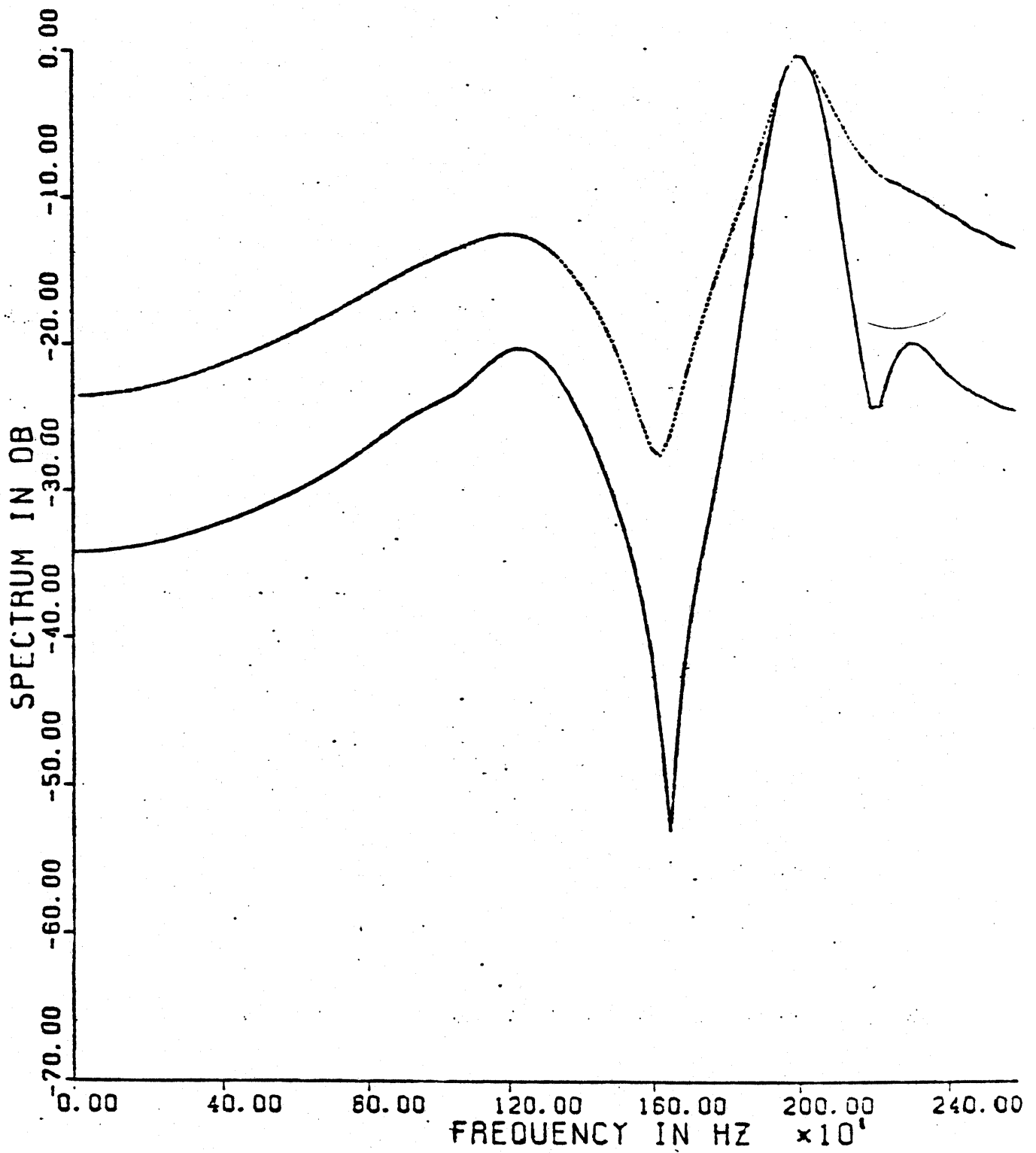

Fig. 15. Detection of a four-pole signal by the CZT with the rectangular (dash) and Tseng (solid) windows. ( $\Delta\sigma=2$ ).

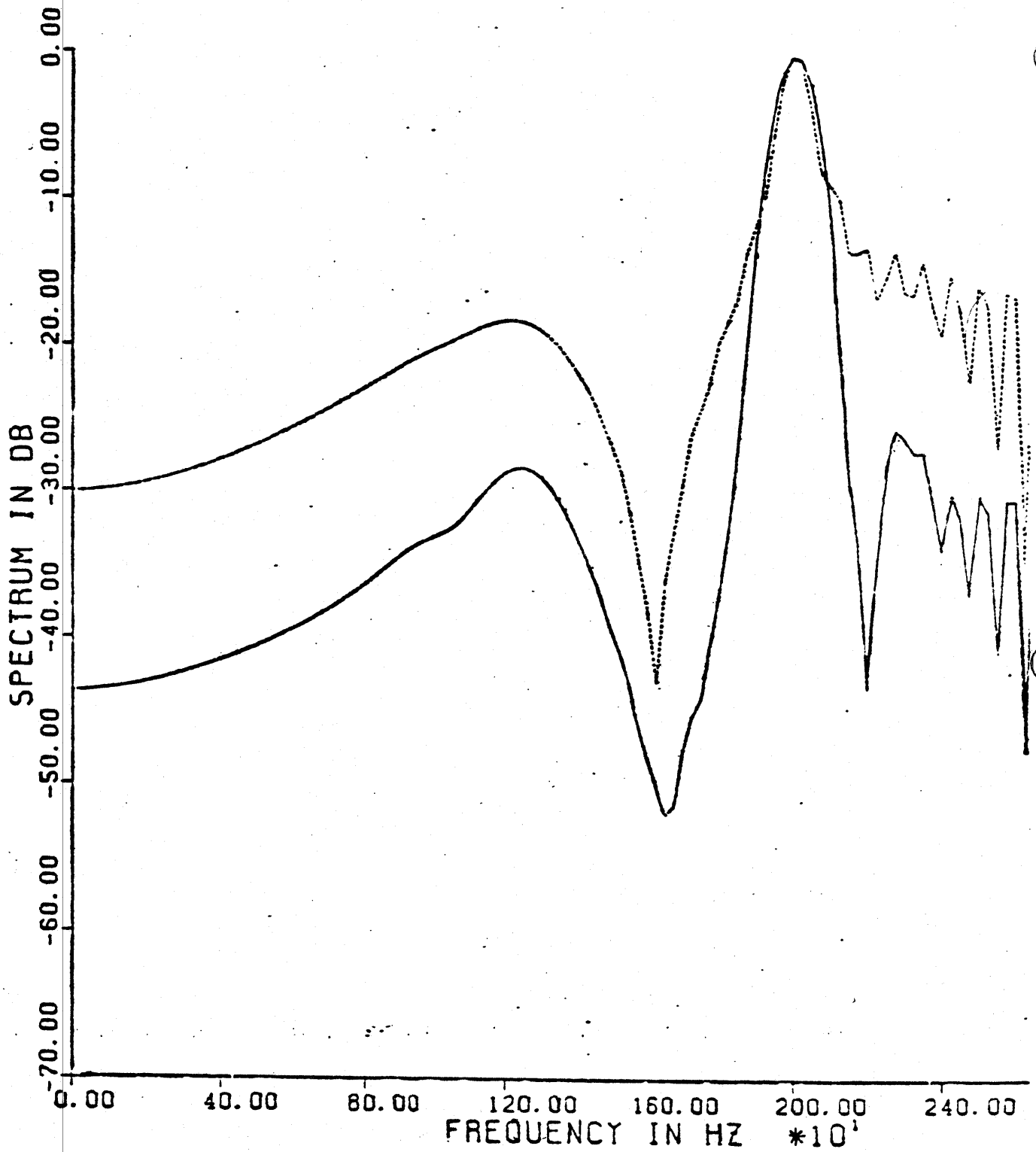

Fig. 16. Detection of a four-pole signal by the CZT with the rectangular (dash) and Tseng (solid) windows. ( $\Delta\sigma=3$ ).

distorting the spectrum peak at  $f_4$ . If the contour is now further tilted to  $\Delta\sigma=4$ , the high frequency noise becomes worse and the small pole at  $f_1$  still is not resolved (see Fig. 17). In all four contours evaluated the rectangular window never detected the two small poles.

The two examples demonstrated the effectiveness of the CZT and the Tseng window in detecting and resolving a small pole located far away from the  $j\omega$  axis. The examples also illustrated the importance of choosing an appropriate contour. The main limitation of the new technique is the high frequency computational noise. How to cope with this problem is currently being studied. Further research along this line will be reported in the future.

#### V. Conclusion

A new technique for detecting a small pole in the presence of a nearby strong pole is presented in this paper. By simultaneously applying the CZT and Tseng window, the new technique is shown to be able to detect and resolve a small pole. Numerous spectra are plotted for a four-pole system along various contours. These examples demonstrated the effectiveness of the Tseng window as compared to the rectangular window in detecting and resolving a small pole located far away from the  $j\omega$  axis. These examples also illustrated the importance of choosing an appropriate contour in detecting the poles.

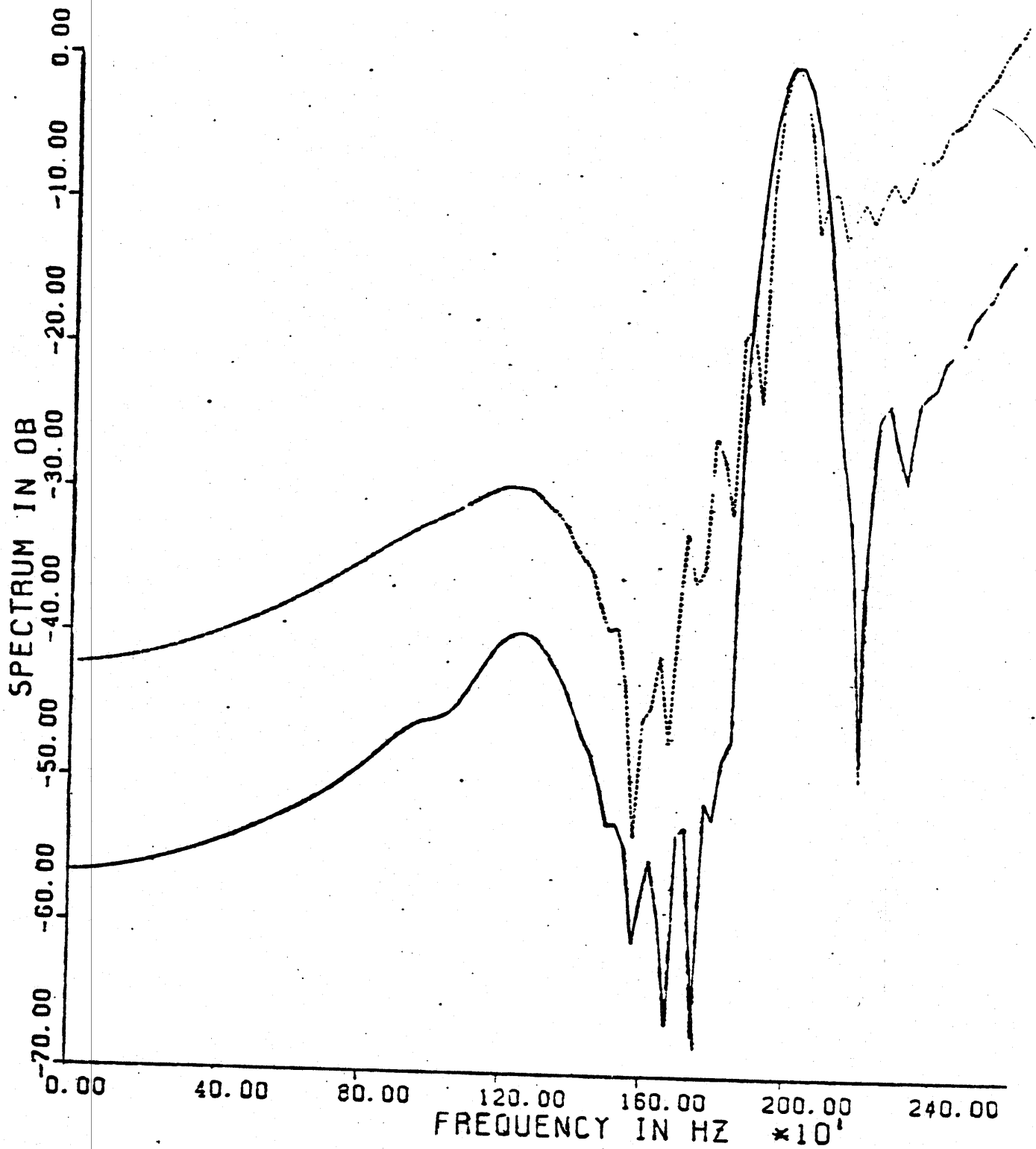

Fig. 17. Detection of a four-pole signal by the CZT with the rectangular (dash) and Tseng (solid) windows ( $\Delta\sigma=4$ ).

## References

- [1] C.E. Baum, "Emerging Technology for Transient and Broad-Band Analysis and Synthesis of Antennas and Scatterers," Proc. IEEE, Vol. 64, No. 11, pp. 1598-1616, Nov. 1976, also Interaction Note 300.
- [2] D.L. Moffatt and R.K. Mains, "Detection and Discrimination of Radar Targets," IEEE Trans. Antennas Propagat., Vol 23, No. 3, pp. 358-367, May, 1975.
- [3] M.L. Van Blaricum and R. Mittra, "Problems and Solutions Associated with Prony's Method for Processing Transient Data," IEEE Trans. Antennas Propagat., Vol 26, No. 1, pp. 174-182, Jan. 1978.
- [4] V.K. Jain, T.K. Sarkar, D.D. Weiner, "Extension of Pencil-of-Function Method to Reverse-Time Processing with First-Order Digital Filters" TR-80-4, Contract N00014-79-C-0598, Aug. 1980.
- [5] M.L. Van Blaricum, "Difficulties Present in Algorithms for Determining the Rank and Proper Poles with Prony's Method," 1979 RADC Spectrum Estimation Workshop, pp. 147-155, Oct. 1979.
- [6] L.R. Rabiner, R.W. Schafer, and C.M. Rader, "The Chirp z-Transform Algorithm and Its Application," The Bell System Technical Journal, May-June 1969.
- [7] F.I. Tseng, T.K. Sarkar and D.D. Weiner, "A Novel Window for Harmonic Analysis." To be published in the IEEE Transactions on Acoustics, Speech and Signal Processing.