

Interaction Notes  
Note 540  
June 30, 1998

## Bounding of Voltage Responses

K.S.H. Lee  
Kaman Sciences Corporation  
Santa Monica, California

L.K. Warne  
Sandia National Laboratories  
Albuquerque, New Mexico

### ABSTRACT

This paper deals with bounding the voltage response at an antenna's terminal with or without a transmission line attached to it. The same attempt is made for the terminals of a multi-conductor transmission line, but much work remains to be done.

Voltage is an important quantity to characterize upset of an electronic device, just as energy is responsible for causing its damage. However, bounding the voltage response is much more difficult than bounding the energy response because for the latter one may invoke, among other things, the principle of energy conservation.

## PREFACE

The authors appreciate the support of and many helpful discussions with Drs. Marv Morris, Ken Chen and Bill Johnson of the Sandia National Laboratories, Albuquerque, New Mexico.

## SECTION 1

### INTRODUCTION

Past efforts have met with some success in bounding the energy absorbed by a resistive load in a transient field [1-5]. The reason for the success is the availability of the integral bound on the absorption area over all wavelengths. Very often the load voltage is a more important quantity than either energy or power, as in the discussion of system upset. A voltage can be induced across an inductance, a capacitance, or a resistor. The real power or energy absorbed by an inductance or a capacitance is of course zero. Thus, in bounding the load voltage in general, one is not helped by the conservation law of energy or power which, together with the causality principle, leads to the integral bound on the absorption area. In the particular case where the load is a resistor and the field is time-varying, one can, however, bound the peak load voltage with the help of the integral bound on the absorption area, as will be discussed in Section 3.

In Section 2, we deal with the simplest problem of a wire antenna (or a 2-wire cable) in a time-harmonic field. We ask, what is the maximum voltage that can be induced in an arbitrary load, whose quality-factor ( $Q$ ) has a limiting value at low frequencies?

In Section 3, we pick up the particular case where the load to the wire antenna is a resistor and the field is time-varying. Using the integral bound on the absorption area and Schwartz inequality, we obtain a bound on the induced peak voltage and compare it with a recent measurement at Sandia.

Finally, in Section 4, we tackle one of the most difficult coupling problems, the problem of a multi-wire line. Conceptually and theoretically speaking, it is a very simple problem. But for a typical multi-wire cable with 30 to 50 pins, the number of parameters is so overwhelming that useful results do not exist. Perhaps, if attention is focused on seeking a bound on the solution, many of the parameters may drop out and the problem becomes manageable. So, we start with a 3-wire cable with a given Norton equivalent circuit, and ask the question, what is the load admittance matrix that would maximize the load voltage responses? The form of the solution to this problem suggests itself how it can be generalized to the  $n$ -wire cable problem. But much more work remains to be done.

## SECTION 2

### MAXIMUM LOAD VOLTAGE IN TIME-HARMONIC FIELDS

In this section we want to get some idea of how large a voltage can be induced in an arbitrary load by considering a simple problem as shown in Figure 1.

Starting from the Norton equivalent circuit (Fig.1) we have for the load voltage  $V_L$

$$V_L = \frac{I_{sc}}{Y_S + Y_L} = \frac{I_{sc}}{G_S + G_L - i(B_S + B_L)} \quad (1)$$

from which we get

$$\begin{aligned} |V_L| &\leq \frac{|I_{sc}|}{G_S + G_L} \leq \frac{|I_{sc}|}{G_S} \\ &= \frac{R_S^2 + X_S^2}{R_S} |I_{sc}| \\ &= \frac{\sqrt{R_S^2 + X_S^2}}{R_S} |V_{oc}| \rightarrow \frac{X_S}{R_S} |V_{oc}| \quad (\text{for } X_S \gg R_S) \end{aligned} \quad (2)$$

The last expression of (2) means that  $V_L$  can be much greater than  $V_{oc}$  for a reactance-dominated source impedance.

Let us define

$$V_{L,max} = \frac{I_{sc}}{G_S} \quad (3)$$

and use, for the high-frequency limit, the solution of the infinitely long cylindrical antenna for  $I_{sc}$  and  $G_S$ . From [6] we have, for broadside incidence,

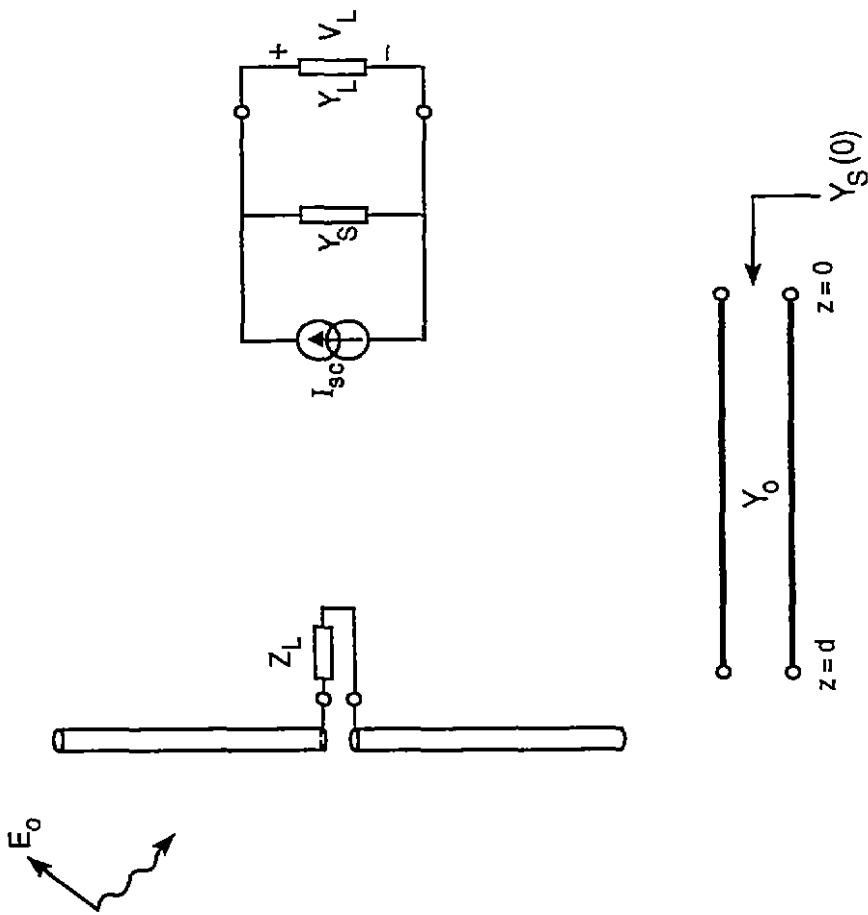

Figure 1. Voltage  $V_L$  induced across load  $Z_L$  or  $Y_L$ .

$$I_{sc} = \frac{4aE_o}{Z_o} \frac{1}{ka H_o^{(1)}(ka)} \quad (4)$$

$$\sim \frac{4aE_o}{Z_o} \frac{1}{ka} \frac{1}{\frac{2i}{\pi} \ln\left(\frac{\gamma ka}{2}\right)}, \quad ka \ll 1$$

and from [7] we have

$$G_S = \frac{\pi}{Z_o \ln\left(\frac{2}{\gamma ka}\right)}, \quad ka \ll 1 \quad (5)$$

Hence,

$$V_{L,max} = \frac{2iE_o}{k} = i \frac{\lambda E_o}{\pi} \quad (6)$$

For a thin-wire antenna of length  $\ell$  one can show that at resonance and broadside incidence [1]

$$I_{sc,n} = \frac{8\ell E_o}{n Z_o C_{in}(2n\pi)}, \quad n = 1, 3, 5, \dots \quad (7)$$

From [8] we also have for the radiation resistance  $R_{S,n}$  at resonance

$$R_{S,n} = 30 C_{in}(2n\pi) \quad (8)$$

Thus,

$$R_{S,n} \cdot I_{sc,n} = \frac{2\ell E_o}{n\pi} \quad (9)$$

By comparing (6) and (9) one sees that, except for the factor  $i$  they are identical if

$$\lambda = 2\ell/n, \quad n = 1, 3, 5, \dots \quad (10)$$

That is to say, at resonance  $V_{L,max}$ , as given by (6), is equal to  $V_{oc}$  (since  $R_S I_{sc} = V_{oc}$ ). If we had used the first inequality of (2) and had taken  $G_L = G_S$ , then  $V_L = V_{oc}/2$  (as should be when  $X_S = X_L = 0$ ).

Let us look at (6) again from a different point of view. We know that the power absorbed by a load is equal to the absorption cross section times the incident Poynting vector, viz.,

$$\frac{1}{2} \frac{|V_L|^2}{R_L} = \frac{|E_o|^2}{2Z_o} \cdot \frac{\lambda^2}{4\pi} G_{pq} \quad (11)$$

When the load is conjugate-matched to the source impedance, we have  $q = 1$ ; and when the polarizations of the incident and transmitted wave are matched, we have  $p = 1$ . In this case

$$|V_L| = \frac{\lambda |E_o|}{2\pi} \sqrt{\frac{\pi G R_S}{Z_o}} \quad (12)$$

From [8] we have

$$\begin{aligned} G R_S &= \frac{Z_o}{\pi} \left[ \frac{\cos(k\ell/2 \cos\theta) - \cos(k\ell/2)}{\sin\theta} \right]^2 \\ &= \frac{Z_o}{\pi} [1 - \cos(\pi\ell/\lambda)]^2, \quad \text{for } \theta = \pi/2 \text{ (broadside incidence)} \\ &= \frac{Z_o}{\pi}, \quad \text{for } \lambda = \frac{2\ell}{n}, \quad n = 1, 3, 5, \dots \end{aligned} \quad (13)$$

Thus, for  $n = \text{odd integers}$  and  $p = q = 1$  we have

$$|V_L| = \frac{\lambda E_o}{2\pi} \quad (14)$$

a factor of 2 less than  $|V_L|_{max}$  given by (6), as was shown before for wires of resonant lengths.

Therefore, it is reasonable to conclude that expression (6) bounds the load voltage from above for wire lengths not less than  $\lambda/2$ .

Let us return to the last expression of (2), namely,

$$|V_L| \leq \frac{X_S}{R_S} |V_{oc}| \quad (15)$$

and examine its low-frequency behavior. At low enough frequencies we know [4]

$$\begin{aligned} V_{oc} &\approx h E_0 = E_0 \ell / 2 \\ X_S &\propto 1/\omega \\ R_S &\propto \omega^2 \end{aligned} \quad (16)$$

Thus the right hand side of (15) goes as  $\omega^{-3}$ . This suggests that below a certain frequency (let it be called  $\omega_0$ ), (15) is meaningless. In other words, at  $\omega = \omega_0$  the load impedance  $Z_L$  can still be made conjugated-matched to the source impedance  $Z_S$ , but for  $\omega < \omega_0$  the matching is no longer practically possible. Let  $Q_0$  be the quality-factor of the load at  $\omega = \omega_0$ . Then (15) gives

$$V_L \leq Q_0 h E_0 \quad (17)$$

at  $\omega = \omega_0$ . The question is if the bound given by (17) is still valid for  $\omega < \omega_0$ .

To answer this question we follow the same procedure given in [4]. Using the Thevenin equivalent circuit we write

$$|V_L| = \sqrt{\frac{R_L^2 + X_L^2}{(R_L + R_S)^2 + (X_L - X_S)^2}} |V_{oc}| \quad (18)$$

Eliminating  $X_L$  in favor of  $R_L$  by means of  $Q_0 = X_L/R_L$  and maximizing (18) with respect to  $R_L$  one obtains, with  $Q_0 \gg 1$ ,

$$V_{L,\max} = \frac{Q_0}{1 + \omega^3/\omega_0^3} V_{oc} \leq Q_0 V_{oc} \quad (19)$$

the same result as (17).



If we equate expressions (6) and (19) at  $\omega = \omega_0$ , we find that

$$\omega_0 = \frac{2c}{Q_0 h} = \frac{4}{\pi Q_0} \omega_1 \approx \frac{\omega_1}{Q_0} \quad (20)$$

where  $\omega_1$  = angular frequency of a half-wavelength resonant dipole. Figure 2 shows the bound of the load voltage  $|V_L|$ . At low enough frequencies,  $V_L$  will behave as  $\omega$  since  $X_S$  will dominate in (18).

Before concluding, consider the situation where there is a piece of transmission line between the load and the antenna (Fig. 1). The short-circuit current  $I_{sc}(0)$  at the load is related to the voltage,  $V_L(d)$ , at the antenna terminal as follows:

$$I_{sc}(0) = \frac{Y_0}{\sinh(\gamma d)} V_L(d)$$

which can be found by solving the transmission-line equations. The source admittance  $Y_S(0)$  looking toward the antenna terminal from the load is

$$Y_S(0) = Y_0 \frac{Y_S(d) + Y_0 \tanh(\gamma d)}{Y_0 + Y_S(d) \tanh(\gamma d)}$$

Consider the transmission line to be slightly lossy so that one can write, with  $\gamma = \alpha - ik$ ,

$$\sinh(\gamma d) \approx \alpha d \cos(kd) - i \sin(kd)$$

Note that if the line is lossless and when  $d$  is a multiple of half-wavelength,  $I_{sc}(0)$  becomes unbounded for any finite value of  $V_L(d)$ . Now, for a line with small loss one can show that with the help of the above expressions

$$|V_L(0)| \leq \frac{2}{\pi} \frac{Y_0}{G_S(d)} \cdot Q_1 |V_L(d)| \leq \frac{2}{\pi} \frac{Y_0}{G_S(d)} Q_0 Q_1 |V_{oc}(d)|$$

where  $Q_1$  is the quality factor defined for the line being a half-wavelength long.

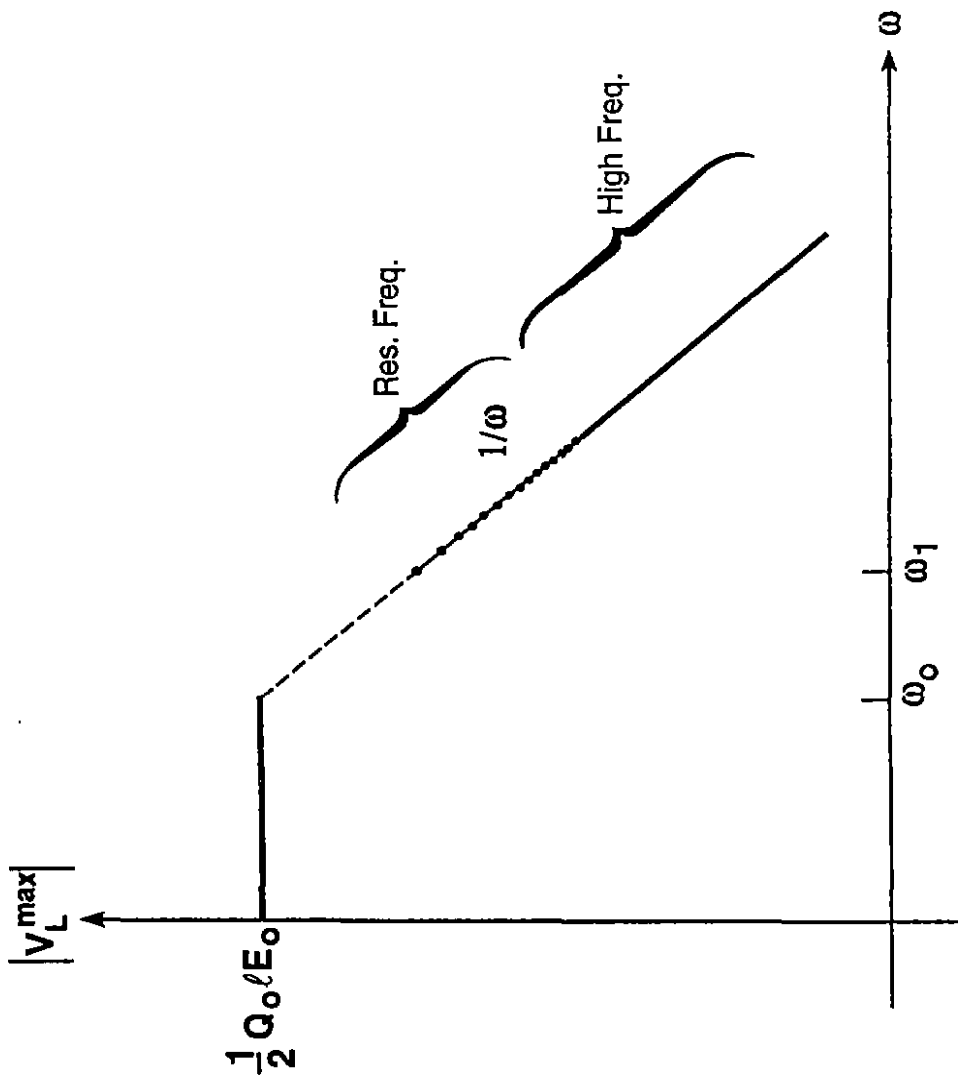

Figure 2. Maximum load voltage of a wire antenna in an external field  $E_0$  (log-log plot).

### SECTION 3

#### MAXIMUM PEAK LOAD VOLTAGE AT A RESISTIVE LOAD IN TRANSIENT FIELDS

Let  $f, g$  be complex functions of the angular frequency  $\omega$ . By the Schwartz inequality we have

$$\begin{aligned} \int |f|^2 d\omega \cdot \int |g|^2 d\omega &\geq \left( \int |f g| d\omega \right)^2 && \text{(Schwartz Ineq.)} \\ &\geq \left| \int f g d\omega \right|^2 \end{aligned} \quad (21)$$

Let  $v(t)$  be the induced voltage across a resistance  $R$ . Then the energy absorbed by  $R$  is given by

$$\begin{aligned} W &= \frac{1}{R} \int_{-\infty}^{\infty} v(t) v(t) dt = \frac{1}{2\pi R} \int_{-\infty}^{\infty} V V^* d\omega \\ &= \frac{1}{2\pi R} \int_{-\infty}^{\infty} (\ell_v E) (\ell_v E)^* d\omega = \frac{Z_0}{2\pi R} \int_{-\infty}^{\infty} |\ell_v|^2 S d\omega \\ &\equiv \frac{1}{2\pi} \int_{-\infty}^{\infty} A_e S d\omega \end{aligned} \quad (22)$$

where  $A_e$  is the effective absorption area, and we also have used

$$v(t) = \frac{1}{2\pi} \int_{-\infty}^{\infty} V(\omega) e^{-i\omega t} d\omega = \frac{1}{2\pi} \int_{-\infty}^{\infty} \ell_v(\omega) E(\omega) e^{-i\omega t} d\omega \quad (23)$$

and  $\ell_v$  = voltage transfer function,  $E$  = incident electric field,  $S$  = incident Poynting vector (J/hertz)

Substituting  $f = \omega E$ ,  $g = \frac{\ell_v}{\omega} e^{-i\omega t_1}$  ( $t_1$  is the time at which  $|v(t_1)| = v_{\text{peak}} \equiv v_p$ )

into (21) we get

$$\int_{-\infty}^{\infty} \omega^2 |E|^2 d\omega \cdot \int_{-\infty}^{\infty} \frac{|\ell_v|^2}{\omega^2} d\omega \geq \left| \int_{-\infty}^{\infty} \ell_v E e^{-i\omega t_1} d\omega \right|^2 = 4\pi^2 v_p^2$$

or

$$v_p^2 \leq \frac{R}{2\pi^3 c} \int_0^{\infty} \omega^2 S d\omega \cdot \int_0^{\infty} A_e d\lambda \quad (24)$$

where  $\lambda$  is the wavelength.

If we use  $f = E$ ,  $g = \ell_v e^{-i\omega t_1}$  we would get from (21)

$$\int_{-\infty}^{\infty} |E|^2 d\omega \cdot \int_{-\infty}^{\infty} |\ell_v|^2 d\omega \geq \left| \int_{-\infty}^{\infty} \ell_v E e^{-i\omega t_1} d\omega \right|^2 = 4\pi^2 v_p^2$$

or

$$v_p^2 \leq \frac{R}{\pi^2} \int_0^{\infty} S d\omega \cdot \int_0^{\infty} A_e d\omega \quad (25)$$

Let us use the right-hand side of (24) to compute the bound and compare it with some recently acquired test data [5]. The test fixture and data are shown in Figure 3. The measured peak voltage was

$$\text{measured } v_p \approx 107 \text{ volts}$$

across a resistive load  $R = 170\Omega$ . The electric field of the incident wave in the test was parallel to the cylinder's axis and described by

$$E^{\text{inc}}(t) = E_0(e^{-\alpha t} - e^{-\beta t}) \quad (26)$$

with  $E_0 = 60 \text{ kV/m}$ ,  $\alpha = 3 \times 10^7 \text{ sec}^{-1}$ , and  $\beta = 4 \times 10^9 \text{ sec}^{-1}$ . Hence,

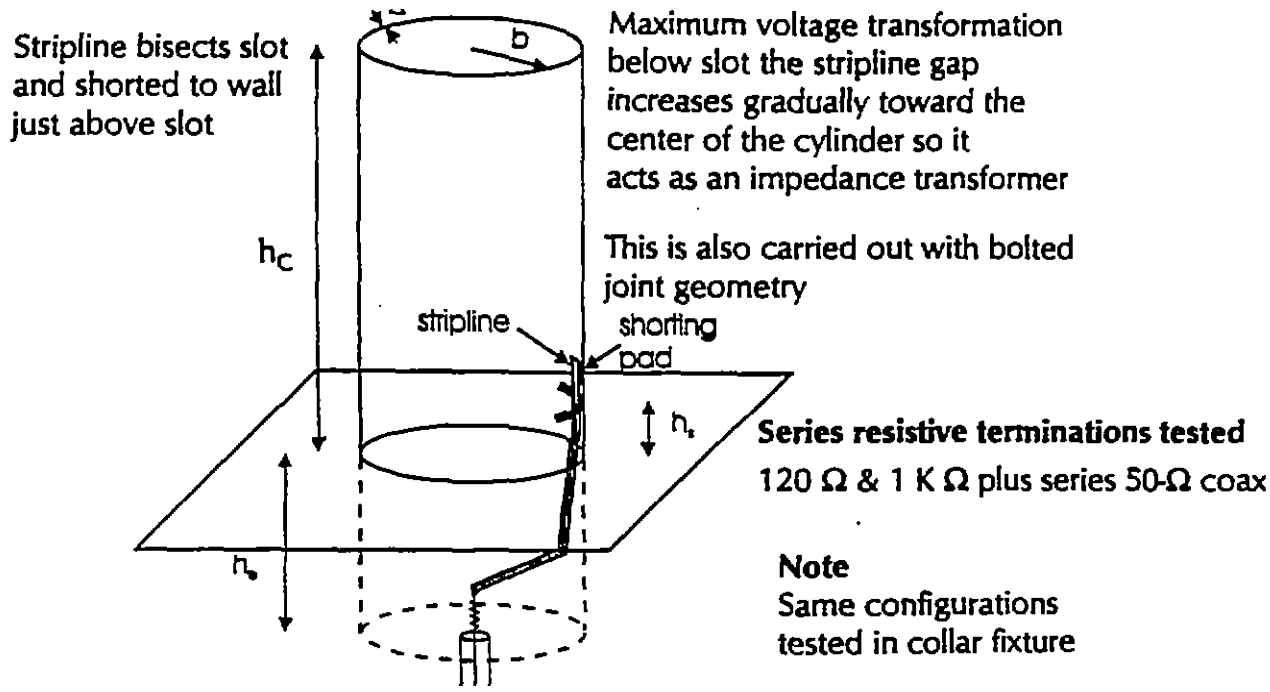

(a) slot test fixture with tapered stripline cable

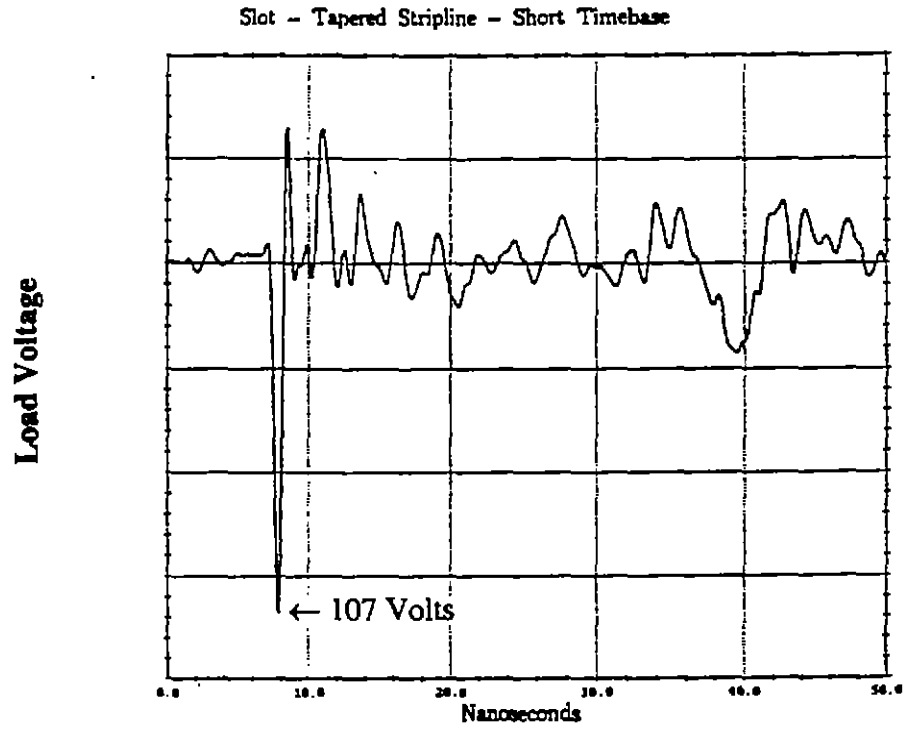

(b) measured voltage waveform

Figure 3. (a) Test setup and (b) example of test result at Sandia.

$$\int_0^{\infty} \omega^2 S d\omega = \frac{E_0^2}{Z_0} \int_0^{\infty} \frac{\omega^2(\beta - \alpha)^2}{(\alpha^2 + \omega^2)(\beta^2 + \omega^2)} d\omega \quad (27)$$

$$= \frac{E_0^2}{Z_0} \cdot \frac{\pi(\beta - \alpha)^2}{2(\beta + \alpha)} \approx \frac{\pi\beta E_0^2}{2Z_0}$$

From previous work on bounds [2,3] we have for apertures

$$\int_0^{\infty} A_e d\lambda \leq \pi^2 4(\alpha_{m,22} - \alpha_{e,11}) = 4\pi^2 \alpha_{m,22}$$

The magnetic polarizability,  $\alpha_{m,22}$ , of the slot in Figure 3, which is a small circular arc of length  $\ell$  about 2.45", width about 0.017" and depth about 0.25", has the following approximate value:

$$\alpha_{m,22} \approx \frac{\ell^3 \pi}{12\Omega_e} \approx 1.05 \times 10^{-6} \text{ m}^3$$

Collecting all the formulas for the right-hand side of (24) we have

$$\frac{R}{2\pi^3 c} \int_0^{\infty} \omega^2 S d\omega \cdot \int_0^{\infty} A_e d\lambda \approx 2.27 \times 10^4 \text{ (volts)}^2$$

That is,

$$v_p^2 \leq 2.27 \times 10^4 \text{ (volts)}^2$$

or

$$v_p \leq 151 \text{ volts}$$

which should be compared with the measured value of 107 volts.

Before concluding, let us discuss briefly (25) and ask, "Under what condition does the equality sign hold?" It is clear that if  $E = a \ell_v^* e^{i\omega t}$  (where  $a = \text{constant}$ ), the equality sign holds, meaning that

$$\frac{v_{p,\max}^2}{R} = 2\xi \int_0^\infty A_e df \quad (28)$$

where  $f$  is the frequency and  $\xi$  is the total fluence of the incident wave defined as

$$\begin{aligned} \xi &= \int_{-\infty}^{\infty} E(t) H(t) dt \\ &= \frac{1}{2\pi} \int_{-\infty}^{\infty} S d\omega \end{aligned}$$

## SECTION 4

### MAXIMUM LOAD VOLTAGES AT MULTI-PIN CONNECTOR

In the preceding two sections we showed how to bound the load voltage at a single-pin antenna terminal. Here, in this section, we try to deal with a much more difficult problem concerning a multi-pin terminal. Before getting into the crux of the problem, we want to get some insight into the problem by deriving the Norton or Thevenin equivalent circuit for a multi-conductor line, first, using the superposition principle and, second, the Lorentz reciprocity theorem.

#### 4.1 Norton/Thevenin Equivalent Circuit

##### a. Superposition

To get an equivalent circuit to represent the inputs to the load in Figure 4(a), we follow the discussions in Guillemin [9] and construct two auxiliary problems shown in Figures 4(b) and (c). Notice the change in the polarities of the voltage sources in the figures. The voltage sources  $V_{S,1}$ ,  $V_{S,2}$ , etc. are so chosen that  $I'_1$ ,  $I'_2$ , etc. into the load are zero. It is clear that by superposition of the two auxiliary problems,

$$\begin{aligned} I_1 &= I'_1 + I''_1 \\ I_2 &= I'_2 + I''_2 \\ &\vdots \\ I_n &= I'_n + I''_n \end{aligned} \tag{29}$$

Since  $I'_1 = I'_2 = \dots = I'_n = 0$  by construction, the load currents  $I_1$ ,  $I_2$ , etc. of the original problem can be obtained from the auxiliary problem #2, which consists of the load, the voltage sources, and the impedance of the linear network, the latter two being the elements of a Thevenin equivalent circuit. A Norton equivalent circuit can be obtained using a similar procedure.

##### b. Lorentz Reciprocity Theorem

Let us consider problems (a) & (b) in Figure 5. The theorem says that

$$\int_{\text{closed surface}} (\mathbf{E}' \times \mathbf{H} - \mathbf{E} \times \mathbf{H}') \cdot \hat{\mathbf{n}} \, dS = 0 \tag{30}$$



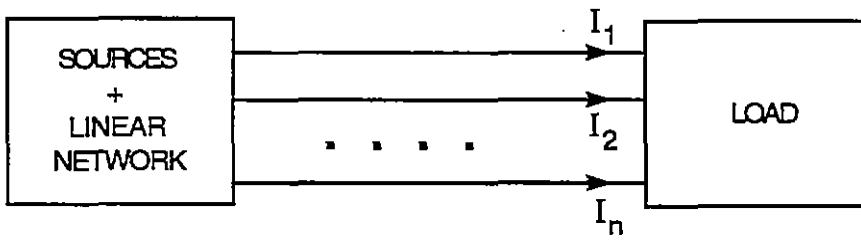

(a) Original Problem

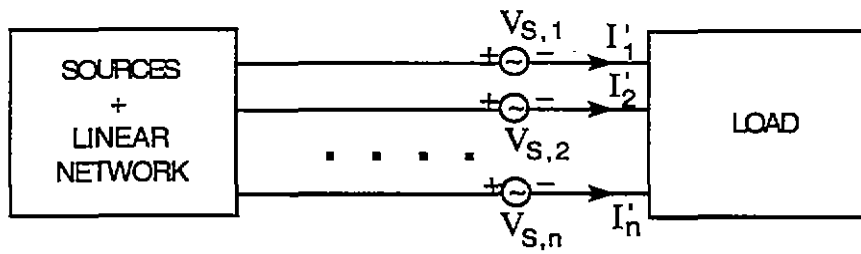

(b) Auxiliary Problem #1

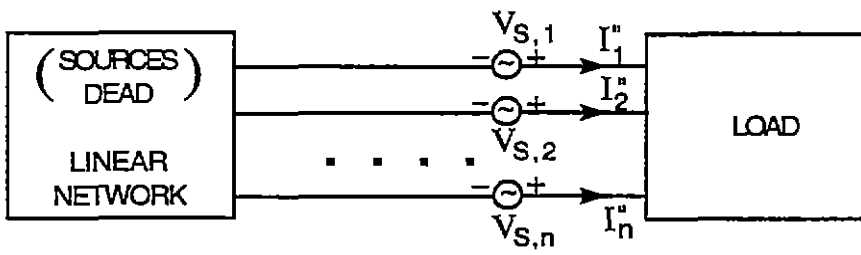

(c) Auxiliary Problem #2

Figure 4. Application of superposition.

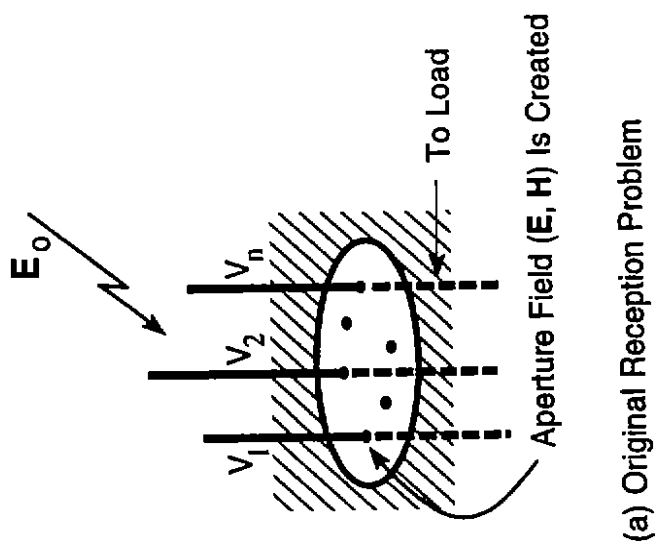
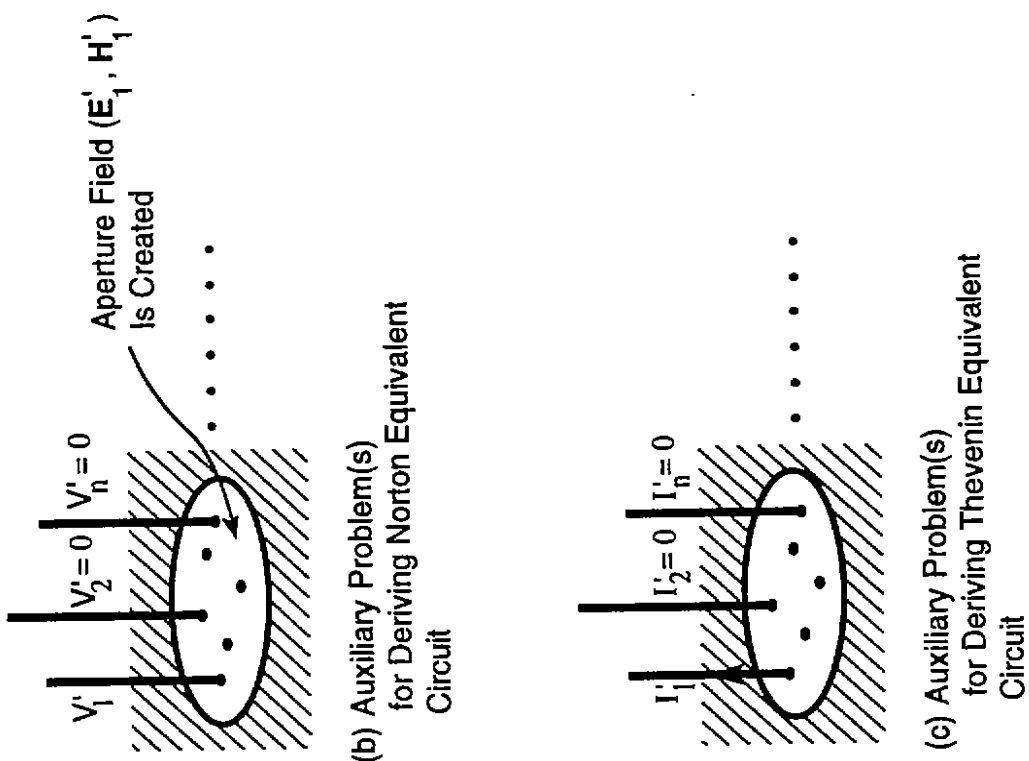

Figure 5. Field-theoretic considerations of Norton and Thevenin equivalent circuits for a multi-conductor line.

over a closed surface which encloses no sources, where  $(\mathbf{E}, \mathbf{H})$  and  $(\mathbf{E}', \mathbf{H}')$  are fields referring to problem (a) and problem (b), respectively. Let the closed surface be the surface over the aperture ( $S_A$ ) plus another surface ( $\bar{S}_A$ ). Then (30) can be written as

$$\int_{S_A} (\mathbf{E}' \times \mathbf{H} - \mathbf{E} \times \mathbf{H}') \cdot \hat{\mathbf{n}} \, dS = - \int_{\bar{S}_A} (\mathbf{E}' \times \mathbf{H} - \mathbf{E} \times \mathbf{H}') \cdot \hat{\mathbf{n}} \, dS \quad (31)$$

Assuming the aperture to be electrically small (or distorting  $S_A$  into the region behind the aperture so that only TEM modes exist there) one obtains for the left hand side of (31) [10],

$$V_1' I_1 + (V_1' I_1' + V_2' I_2' + \dots + V_n' I_n') = A_1 \quad (32)$$

where  $A_1$  denotes the integral on the right hand side of (31). Dividing both sides by  $V_1'$  we get

$$I_1 + Y_{11}' V_1 + Y_{12}' V_2 + \dots + Y_{1n}' V_n = I_{1,sc} \quad (33)$$

where  $Y_{11}' = I_1'/V_1'$ ,  $\dots$ ,  $Y_{1n}' = I_n'/V_1'$  and  $I_{1,sc} = A_1/V_1'$ . When  $V_1 = V_2 = \dots = V_n = 0$ ,  $I_1$  is called the short-circuit current, which is denoted by  $I_{1,sc}$ . Repeating the same procedure with the second conductor at  $V_2'$  (Fig. 5b) and all other conductors at zero voltage, and so on, one obtains

$$\begin{aligned} I_2 + Y_{21}' V_1 + Y_{22}' V_2 + \dots + Y_{2n}' V_n &= I_{2,sc} \\ \vdots & \\ I_n + Y_{n1}' V_1 + Y_{n2}' V_2 + \dots + Y_{nn}' V_n &= I_{n,sc} \end{aligned} \quad (34)$$

Equations (33) and (34) can be written in the form

$$I_n + Y_{S,nm} V_m = I_{n,sc} \quad n = 1, 2, \dots \quad (35)$$

where we have used  $Y_{S,nm}$  for  $Y_{nm}'$  and repeated indices are summed. Equation (35) is the content of the Norton equivalent circuit relating  $(V_n, I_n)$  to the source parameters  $(I_{n,sc}, Y_{S,nm})$ . The other relation between  $V_n$  and  $I_n$  is provided by the load admittance matrix  $Y_{L,nm}$

$$I_n = Y_{L,nm} V_m \quad (36)$$

Similarly, a Thevenin equivalent circuit can be obtained by considering Figures 5(a) and 5(c).

#### 4.2 Maximum Load Voltages

Substituting (36) in (35) we get

$$(G_{nm} - iB_{nm}) V_m = I_{n,sc} \quad (37)$$

where  $G_{nm}$  ( $B_{nm}$ ) is the sum of the source and load conductance (susceptance) matrices. Given a source admittance matrix and short-circuit current vector, is there a load admittance matrix that maximizes the load voltage vector?

Let us work out the case of a three-conductor line, one of which is a reference conductor. Thus, we have from (37)

$$\begin{pmatrix} a & b \\ b & c \end{pmatrix} \begin{pmatrix} V_1 \\ V_2 \end{pmatrix} = \begin{pmatrix} I_{1,sc} \\ I_{2,sc} \end{pmatrix} \quad (38)$$

where  $a = a_1 + i a_2 = G_{11} - i B_{11}$ ,  $b = b_1 + i b_2 = G_{12} - i B_{12}$ ,  $c = c_1 + i c_2 = G_{22} - i B_{22}$ . The solution of (38) is

$$V_1 = \frac{c I_{1,sc} - b I_{2,sc}}{\det} \quad (39)$$

$$V_2 = \frac{a I_{2,sc} - b I_{1,sc}}{\det}$$

where

$$|\det|^2 = (a_1 c_1 - b_1^2 - a_2 c_2 + b_2^2)^2 + (a_1 c_2 + c_1 a_2 - 2b_1 b_2)^2 \quad (40)$$

from which it can be shown that one can make  $|\det| = 0$  if and only if

$$b_1^2 \geq a_1 c_1 \quad (41)$$

in which case,  $V_1$  and  $V_2$  have no upper bounds.

In most practical cases, however, the cross coupling is either inductive or capacitive, i.e.,  $b_1 \approx 0$ . In this case

$$\min |\det| = a_1 c_1 \quad (42)$$

since  $a_2$ ,  $b_2$  and  $c_2$  can be rendered to zero by tuning out the susceptance part of the source admittance matrix with a reactance load admittance matrix. With (42) and the choice of  $a_2=b_2=c_2=0$ , we have from (39)

$$\begin{aligned} |V_1| &= \frac{|I_{1,sc}|}{a_1} \leq \frac{|I_{1,sc}|}{G_{S,1}} \\ |V_2| &= \frac{|I_{2,sc}|}{c_1} \leq \frac{|I_{2,sc}|}{G_{S,2}} \end{aligned} \quad (43)$$

from which one is tempted to generalize (43) for a n-port terminal to

$$|V_m| \leq \frac{|I_{m,sc}|}{G_{S,mm}} \quad m = 1, 2, \dots, n \quad (44)$$

Let us look at the cross coupling case and set  $b_1=0$ ,  $I_{sc,1}=0$  in (39). By choosing  $a_2=c_2=0$  (to make  $|\det|$  small) we have

$$\begin{aligned} |V_1| &= \frac{|b_2| |I_{sc,2}|}{a_1 c_1 + b_2^2} \\ |V_2| &= \frac{a_1 |I_{sc,2}|}{a_1 c_1 + b_2^2} \leq \frac{|I_{sc,2}|}{c_1} \end{aligned} \quad (45)$$

It is clear that  $|V_1| \geq |V_2|$  for certain values of  $a_1$ ,  $c_1$  and  $b_2$ , meaning that cross coupling can be greater. Thus, even for the "simple" 3-wire problem one cannot find a satisfactory bound for the two pin voltages except that they can be infinite if condition (41) is met.

Perhaps, one should seek a statistical approach, especially for the case where  $n$  is large,  $n$  being the number of wires. If one assumes that the phase angles of all the pin voltages are uniformly distributed, then the sum,  $|\sum V_L|$ , has a Rayleigh distribution, i.e.,

$$f_{|\sum V_L|}(v) = \frac{ve^{-v^2/2v_0^2}}{v_0^2} \quad (46)$$

where  $v_0$  is the most probable value of  $|\sum V_L|$ , and the expected value is given by

$$E[|\sum V_L|] = \sqrt{\frac{\pi}{2}}v_0 \quad (47)$$

Note that the distribution density function (46) also applies to the magnitude of the sum of the load currents if the same assumption holds, and it is the same distribution that one uses for one component of the field in an over-moded cavity.

## REFERENCES

- [1] K.S.H. Lee and F.C. Yang, "On the Bounds of RF Coupling by Impulse and Step-Function Waveforms," Interaction Notes, Note 491, September 1992.
- [2] K.S.H. Lee and F.C. Yang, " Trends and Bounds in RF Coupling to a Wire Inside a Slotted Cavity," IEEE Trans. on EMC Vol. 34, No. 3, August 1992.
- [3] L.K. Warne and K.C. Chen, " A Bound on Aperture Coupling from Realistic EMP," IEEE Trans. on EMC, Vol. 36, No. 2, May 1994.
- [4] L.K. Warne, T.E. Koontz and K.C. Chen, "EM Penetration Bounds," Sandia Memo, August 1988.
- [5] L.K. Warne, et al, "Validation of EMP Bounds," SAND96 •1460-UC-700, July 1996.
- [6] R.W.P. King and T.T. Wu, The Scattering and Diffraction of Waves, Harvard University Press, 1959.
- [7] C.H. Papas, "On the Infinitely Long Cylindrical Antenna," J. Appl. Phys. Vol. 20, No. 5, 437-440, May 1949.
- [8] C.H. Papas, Theory of Electromagnetic Wave Propagation, Dover, 1988.
- [9] E.A. Guillemin, Introductory Circuit Theory, John Wiley & Sons, Inc. New York, 1953.
- [10] R.W. Latham and K.S.H. Lee, " A Subtraction Procedure in Antenna Theory," Radio Science, Vol. 4, No. 4, April 1969.