

Interaction Notes

Note 439

28 February 1983

Unification of Electromagnetic Specifications and Standards  
Part II: Recommendations for Revisions of Existing Practices\*

W. Graf, J. M. Hamm, E. F. Vance  
SRI International  
333 Ravenswood Ave.  
Menlo Park CA 94025

Abstract

This report documents Phase II of a program on unification of electromagnetic specifications and standards. During Phase I, existing specifications and standards were reviewed against a general interference control model. Alternative techniques to the incompatible ones identified in the review are discussed in this report. Analysis was supported by laboratory experiments in the areas of grounding techniques, cable shield terminations, and aperture coupling. Extensive discussions are included on the allocation of protection and methods of incorporating it in specifications for EMP, lightning, and other external sources. Areas that need further research are identified, including the need to characterize system-generated interference, and the issue of generalized standards and design guidelines. An appendix on bounding aperture coupling is also included.

CLEARED FOR PUBLIC RELEASE

DNA 5433F-2

Approved for public release; distribution unlimited / SEE IA FORM 1473 IN BACK

\* This interaction note is a special issue of DNA Report 5433F-1.  
This work was sponsored by the Defense Nuclear Agency under RDT&E RMSS  
Code B326082466 099QAXCC00002 H2590D, Contract DNA001-79-C-0206, SRI  
Project 8411.

## SUMMARY

The objective of work done under Contract No. DNA 001-79-C-0206 was the development of a compatible set of shielding, bonding and grounding, and installation techniques for communications facilities to ensure that the COMSEC, EMI/EMC, NEC, as well as lightning and electromagnetic pulse protection (EMP) requirements, can be met without mutual conflict. In Phase I (reported in Part I of this report), the pertinent standards, specifications, codes, etc., were collected and evaluated against a comprehensive interference control model to identify incompatible requirements among these documents. In Phase II (reported here), alternatives to the incompatible requirements have been developed and demonstrated.

Following a brief review of Phase I, we define what we mean by "incompatible practice;" it is a practice that is not compatible with the fundamental approach to broad-band electromagnetic interference control. Most incompatible practices found during the review of documents in Phase I can be traced to two generic practices: the use of a penetrating ground conductor and the use of a cable shield that is open. We present arguments to show that there is rarely a need for a grounding conductor to penetrate an electromagnetic barrier. In the general approach to interference control described in Part I, a cable shield is viewed as an extension of the barrier surface represented by the equipment housing. Thus, the proper termination is to close the cable shield by making it continuous with the equipment case.

A rationale was presented in Part I of this report for designing the barrier such that it reduces the stress caused by an external source to a level below the susceptibility threshold of the protected system. In Part II, we discuss several remaining key issues: (1) how to identify the best threshold, (2) how to specify this threshold, (3) how to incorporate this information into the specification of the barrier, and (4) how to test and qualify the barrier.

Laboratory experiments were performed in three areas: grounding practices, shield terminations, and aperture coupling. The experiments demonstrate that a grounding conductor that does not penetrate a barrier surface is superior to one that does by more than 100 dB, even at low frequencies. Best overall performance for cable shields is achieved with a circumferential termination, although at the lowest frequencies such a termination may be indistinguishable from a pigtail. When a twisted pair cable is used, much can be gained by balancing both source and load; if a shield is used, it should again be terminated circumferentially.

Apertures -- holes, seams, joints -- can be significant points of entry for electromagnetic interference. To prevent an aperture from becoming an entry point, the system designer must determine quantitatively the effects of an aperture on the internal voltages and currents. He must then develop means to close those apertures that adversely affect system performance. These aperture problems are closely tied to the problems of developing meaningful specifications, standards, and test procedures. Several parameters can be used to define a measurable performance criterion for apertures: energy, fields, or currents and voltages on internal wiring. The electromagnetic coupling properties of the aperture and the system susceptibility to EMI must be able to be expressed in terms of the parameters chosen to characterize aperture performance. Experiments were performed to support analysis of aperture coupling by SRI and others.

To develop an EMP protection system specification, we must be able to determine how much protection is needed, how many barriers are desired, how the protection is to be allocated among these barriers, and the effects of barrier size, shape, location, and other design options. We discuss these issues in detail and elaborate on the need to verify that the desired protection has been obtained, and on the need to maintain that protection. All features of the EMP protection must be compatible with all other electromagnetic aspects of a system or facility.

In a two-level, effectively impervious barrier system, all requirements directly related to the EMP, lightning, and other external sources are confined to the outermost barrier (the facility level), and only requirements for intrafacility compatibility are imposed on the boxes, cabinets, etc., that form the second-level barrier. Therefore, the protection role of the first barrier is somewhat different from that of the second barrier. How this affects facility and equipment standards is discussed.

Many of the issues that affect the specification and design of systems that can survive exposure to the nuclear EMP have been clarified by the research performed under this program. Areas in which further research and development are needed have been better defined: the problem of allocation of protection, the need for a better understanding of system-generated transients, how such transients should be characterized, the uniqueness of the EMP survivability and its impact on maintenance and surveillance, and the issue of generalized standards and design guidelines.

An appendix on bounds on aperture coupling describes some theoretical work on that topic, as well as details on the aperture coupling experiments performed under this contract.

## PREFACE

In this second phase of a program to unify electromagnetic standards, specifications, and design guidelines, we have developed some alternatives to the incompatible requirements described in Part I of this report.

This phase has benefited from numerous discussions with colleagues, and many of the ideas presented in this report are a direct outgrowth of such discussions. The names of those who contributed in one way or another are too numerous to be listed here. Nonetheless, we are grateful for all the support and criticism we have received during this work from colleagues and audiences alike. Thus, the work reported here has been reviewed to some extent by others, at least in bits and pieces. Final responsibility for errors and omissions, however, rests solely with the authors.

TABLE OF CONTENTS

<u>Section</u>	<u>Page</u>
SUMMARY . . . . .	2
PREFACE . . . . .	4
LIST OF ILLUSTRATIONS . . . . .	7
I COMPATIBLE SPECIFICATIONS . . . . .	8
A. Introduction . . . . .	8
B. Incompatible Practices . . . . .	8
1. Penetrating Ground Conductors . . . . .	9
2. Cable Shield Terminations . . . . .	11
C. Consistency and Effectiveness . . . . .	11
D. Key Issues . . . . .	12
1. Threshold Considerations . . . . .	12
2. Threshold Specification . . . . .	13
3. Barrier Specification . . . . .	14
4. Qualification Tests . . . . .	14
E. Revision of Existing Specifications . . . . .	17
II VERIFICATION OF NEW TECHNIQUES . . . . .	18
A. Overview of Experiments . . . . .	18
B. Grounding Practices . . . . .	18
C. Shield Terminations . . . . .	21
1. Background . . . . .	21
2. Shielded Single Wire . . . . .	22
3. Shielded Twisted Pair . . . . .	24
4. Conclusions . . . . .	26
D. Aperture Coupling . . . . .	26
1. Theoretical Background and Implications . . . . .	28
2. Relationship of Apertures to EMP Specifications, Standards, and Test Procedures . . . . .	34
III SPECIFICATION OF EMP PROTECTION . . . . .	36
A. General . . . . .	36
B. Electromagnetic Compatibility . . . . .	37
C. Allocation of EMP Protection . . . . .	39
D. Characterization of Internal Environment . . . . .	41

TABLE OF CONTENTS (concluded)

<u>Section</u>	<u>Page</u>
IV RECOMMENDATIONS FOR SPECIFICATIONS . . . . .	47
A. Introduction . . . . .	47
B. First Barrier — System or Facility Protection . . . . .	48
C. Second Barrier — Equipment Case . . . . .	50
V RECOMMENDATIONS FOR FUTURE WORK . . . . .	52
A. Allocation of Protection . . . . .	52
B. System-Generated Environment . . . . .	53
C. Characterization of Transients . . . . .	53
D. Maintenance and Surveillance . . . . .	54
E. Generalized Standards . . . . .	55
F. Preparation of Design Guidelines . . . . .	55
REFERENCES . . . . .	57
APPENDIX: BOUNDS ON APERTURE COUPLING . . . . .	59

LIST OF ILLUSTRATIONS

<u>Figure</u>		<u>Page</u>
1	Internal and External Ground Connections . . . . .	11
2	Barrier Effectiveness Requirement . . . . .	13
3	Test Setup . . . . .	19
4	Open-Circuit Voltage $V_{oc}$ as a Function of Frequency . . . . .	20
5	Experiments With Coaxial Cable (RG 62/U) . . . . .	22
6	Experiments With Shielded Twisted Pair . . . . .	25
7	Shielded Volume With Apertures and Wire Penetrations . . . . .	27
8	Aperture Coupling Example . . . . .	28
9	Electric Field Aperture-Coupling Geometry . . . . .	29
10	Magnetic Field Aperture-Coupling Geometry . . . . .	29
11	External Surface Current Density and Induced Aperture Voltage . . . . .	31
12	Equivalent Circuit For Mesh-Covered Aperture With Measured and Predicted Aperture Voltage Reduction Factors . . . . .	32
13	Geometry of Wire Behind Aperture and Transmission Line Coupling Model . . . . .	33
14	System and Units and Their Associated Sources of Interference . . . . .	37
15	System With Exterior Sources . . . . .	39
16	"First Barrier" Allocation . . . . .	40
17	Limit on Rate of Rise or Bandwidth Inside EMP Barrier . . . . .	44
18	Comparison of EMP-induced Current to System-Generated Current . . . . .	45
A-1	Aperture Coupling Example . . . . .	59
A-2	Geometry of Wire Behind Aperture and Transmission Line Coupling Model . . . . .	60
A-3	Test Configuration . . . . .	62
A-4	Field Vectors and Surface Current at Aperture . . . . .	63
A-5	Pulse Source For Parallel Plate Region . . . . .	63
A-6	Electric Field in Center of Parallel Plate Region . . . . .	64
A-7	Loaded Wire in Test Volume . . . . .	64
A-8	Currents Measured on Wire in Test Volume . . . . .	65

## I COMPATIBLE SPECIFICATIONS

### A. INTRODUCTION.

In the final report for Phase I of this project,<sup>\*</sup> we described a rationale for developing compatible electromagnetic specifications. The motivation for this project came from experience with ground-based facilities, where in some cases it was found to be prohibitively costly to harden a facility against the effects of a nuclear electromagnetic pulse (EMP), because the installation practices used originally were incompatible with EMP requirements. Part I described a topological approach to interference control and argued that any electromagnetic specification or standard compatible with these topological principles would, in the long run, be more cost-effective. It was also speculated that interference control could be achieved in a more effective manner in the technical sense, because some marginally effective current practices would be replaced with more effective practices. Since then we have performed numerous laboratory experiments, some of which are described in Section II, to support those claims.

The recommended compatible techniques are not limited to ground-based facilities. They can be applied equally well to airborne systems, ships, and spacecraft, sometimes with minor modifications. Originally the program was driven by the desire to make other standards and practices compatible with EMP requirements. However, we have been able to examine interference control at a fundamental level, and as a result, all electromagnetic disciplines will benefit. The long-term goal is still a unified electromagnetic specification and standard, embracing all electromagnetic disciplines in a compatible way. In the interim, existing standards can be revised to recommend and permit compatible practices. Our review of over 70 military and civilian specifications and standards (see Part I) revealed many standards that permit incompatible practices, but only a few that require incompatible practices, primarily involving grounding and shielding.

### B. INCOMPATIBLE PRACTICES.

Let us define what we mean by "incompatible practice." It is a practice that is not compatible with the fundamental approach to broadband EM interference control. This

---

<sup>\*</sup>"Unification of Electromagnetic Specifications and Standards, Part I: Evaluation of Existing Practices," hereafter referred to as Part I, Interaction Note 420, dtd 15 July 81.



approach, described in Part I, implements interference control by placing an effectively impervious barrier between the source of interference and a potential victim. This definition is useful as long as interference control is interpreted as broadband separation of source and victim. In that case, any practice that is compatible with the fundamental approach will also be compatible with all other such practices. Any practice that is incompatible with the fundamental approach will be incompatible with some other practices.

During the review of the electromagnetic specifications, standards, and installation guidelines, it became clear that the terms "grounding," "bonding," and "shielding" are used very loosely, and often the wrong terms are used. We have devoted a full chapter in Part I on this subject, and we stress again that a clear understanding of the functions that these terms describe is important for effective interference control techniques. We briefly repeat the definitions of the three terms here.

Bonding, probably the easiest of the three terms, is simply the act of making a good electrical (and mechanical) connection. Good grounding and shielding practices depend on good bonding.

Grounding is making a conducting connection either to earth or some other conducting body. The primary goal of grounding is safety for personnel, equipment, and buildings. Grounding can prevent dangerous potential differences between nearby objects, prevent static charge buildup, and provide a path for fault or lightning currents. Grounding cannot eliminate interference or provide an infinite current sink.

Shielding is a valuable interference control technique. To be effective, a shield must be closed. If it is closed, it is immaterial whether it is grounded or not -- the function of the shield is influenced by the closure, not by grounding. This is also true for cable shields: the question for interference control is not whether the cable shield is grounded at one end or at both ends; the cable shield must be closed at both ends.

Most incompatible practices found during the review can be traced to two generic practices: using a penetrating ground conductor, and using a cable shield that is open (it may or may not be grounded). Therefore, these two practices were studied extensively, and laboratory experiments, discussed in the next section, were conducted to demonstrate the effects of penetrating ground conductors and open cable shields.

#### 1. Penetrating Ground Conductors.

A grounding conductor that penetrates a barrier connects the two volumes that the barrier would otherwise separate. As a consequence, any interference present in one volume will be coupled to the other. Strictly speaking, the violation of the barrier is only a local one. However, because of the ubiquitous nature of many ground conductors, the inter-

ference may be distributed throughout the protected volume. A "signal reference" system may thus become an interference distribution system.

There is rarely a good reason for a grounding conductor to penetrate an electromagnetic barrier. However, some installation practices are firmly established and may take some time to change. Following are a few of the reasons that are frequently cited for the necessity of such penetrations.

Safety: Although the National Electric Code (NEC) does not require that the green wire penetrate metal surfaces, it certainly permits the practice. The purpose of the green wire is to provide a path to the earth ground for the fault current to flow. It is immaterial whether this path consists of a single wire, or whether it includes parts of sheet or other metal, as long as the conductive path is continuous and not easily interrupted.

Signal Reference: It is often desirable to interconnect different circuits, or even different equipment units. Since the circuits and equipment may not be at the same potential, it has been proposed that their signal references should be connected together to bring them to the same potential. At dc, equalizing the potential is limited only by the IR drop along the signal reference conductor; this potential drop can be made reasonably small. However, no information can be transmitted at dc. At the interference frequencies, the inductance of the signal reference conductor, and thus the  $I\omega L$  drop, becomes important. Reducing the inductance of a long conductor is not practical. Hence, equalizing the potential of equipment units separated by more than a few feet cannot be achieved realistically, i.e., at the interference frequencies. Furthermore, if other connections are made to a common earth ground point, such as lightning downconductors and power grounds, the potential of the "reference" point may fluctuate many orders of magnitude. The connection to the earth ground point allows lightning and power-switching transients to propagate onto the signal reference conductor. When a signal reference is confined to the inside of a metal equipment case, it is completely within a zone, so either a single or a multiple ground can be used. The requirement for a penetrating ground conductor thus vanishes. Furthermore, interference waves on the grounding conductor cannot propagate through the barrier.

Lightning: Since lightning is a transient phenomenon, a lightning conductor should never penetrate a barrier surface if it is desired to keep the transients outside the barrier.

To summarize, any grounding conductor can be terminated on a barrier surface and regenerated on the other side, instead of routing it through the barrier. One way of doing this is shown in Figure 1. The experiments described in Section II show how much can be gained by a topological ground design compared to a penetrating ground.

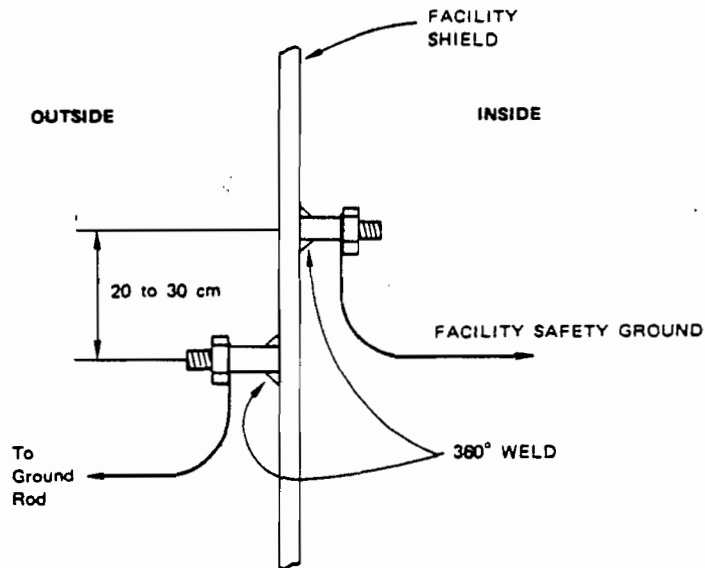

FIGURE 1 INTERNAL AND EXTERNAL GROUND CONNECTIONS

## 2. Cable Shield Terminations.

In the general approach to interference control described in Part I, a cable shield is viewed as an extension of the barrier surface represented by the equipment housing. Thus, the proper cable shield termination is to close the cable shield by making it continuous with the equipment case. A closed electrodynamic shield works whether it is grounded or not. Thus, grounding the shield — but leaving it open — will only provide electrostatic protection, but no dynamic attenuation.

If two equipment units are connected by a shielded cable, the shield should be connected peripherally to the equipment housing. In some applications this may lead to an undesirable ground loop. To correct this, the loop current should be interrupted, but not by interrupting the shield. For example, either one of the equipment units might be floated. The effects of interrupting the shield are demonstrated by the experiments, described in Section II, which show that at some frequencies the penalty for not closing the shield can be severe.

## C. CONSISTENCY AND EFFECTIVENESS.

Electromagnetic compatibility (EMC) practices sometimes conflict with each other (see Part I) as well as with practices for developing immunity against broadband electromagnetic threats. For example, when an existing system is to be hardened against the EMP, extensive changes may be necessary in the design of the system ground, penetration treatments, and

configuration. Sometimes it is less expensive to build a new facility than to harden an existing one, particularly if only part of the functions of the existing system need to survive the EMP and if traditional interference control procedures have been used. However, even the hardening of new systems is frequently more expensive than it need be because of the extensive effort required to ensure that some of the common practices do not subvert the hardening design.

For these reasons, it seems advantageous to develop interference control standards and techniques that do not conflict with each other or with EMP hardening techniques. Including such techniques in new system designs is cost-effective, since only minimal changes would be required if EMP hardening is specified at a later time. Furthermore, all interference control techniques will be more cost effective if techniques are used without mutual conflicts.

#### D. KEY ISSUES.

A closed barrier that separates the source from the victim is the fundamental element in the approach to broadband interference control. A rationale has been presented in Part I for making the barrier reduce the stress caused by an external source to a level below the threshold of the protected system. However, many key issues still need to be resolved: (1) how to identify the best threshold, (2) how to specify this threshold, (3) how to incorporate this information into the specification of the barrier, and (4) how to test and qualify the barrier. These issues are discussed below. Whether immunity should be allocated at the system level, unit level, or both must also be determined. This issue is addressed in Section III.

##### 1. Threshold Considerations.

The damage level of a system (subsystem or component) might seem to be a logical choice as the threshold to be specified. However, damage levels even for components (let alone subsystems and systems) are ill-defined and are usually not controlled or specified by manufacturers. The damage level for a component may differ by orders of magnitude for the same component from two manufacturers, or even from two lots made by the same manufacturer, and the spread of the damage level within one lot of components may be large. Attempts have been made to deal with the damage level on a statistical basis, but damage statistics do not always obey simple distributions. Furthermore, in the case of EMP hardness, the use of damage as a threshold often requires confidence that the system will tolerate a larger stress in the event of war than it is ever exposed to in peacetime.

Several other thresholds require consideration: the level of system-generated transients, the upset level, the level of interference at which no change occurs in the

mean time between failure, and the system operating level. These are probably all (except the operating level) close to the same level and are transient levels to which the system is exposed routinely. The level of system-generated transients has the following advantage: the system regularly tolerates the system-generated transients. Hence, if transients caused by external sources (EMP, lightning, switching transients, etc.) are reduced to this level or below, the system should function independently of these external sources. Moreover, because the system-generated transients are always present, the system continually tests itself during normal operation. This last feature is not inherent in thresholds based on the damage level; in fact, it would be difficult to verify that a system is protected against an external source if it had to be tested to the damage level. Figure 2 illustrates the various thresholds.

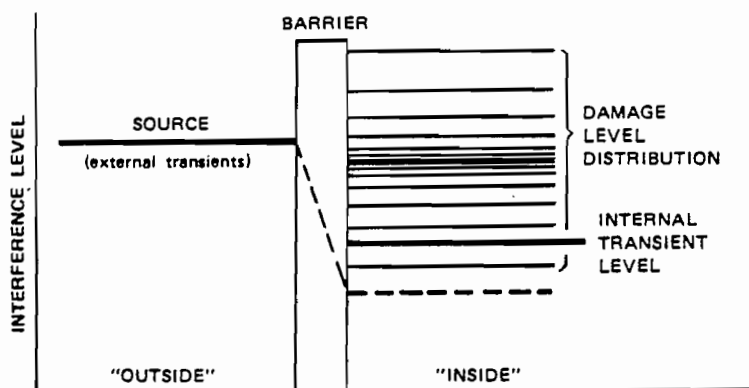

FIGURE 2 BARRIER EFFECTIVENESS REQUIREMENT

In addition to these considerations, the consequences of a particular choice of threshold on accuracy of specification, reliability, system integration, ability to test compatibility with other requirements, confidence in system hardness, and so forth, must be evaluated.

## 2. Threshold Specification.

Once a transient threshold has been selected, it must be quantified. Although it is not yet clear which parameters are necessary to define or specify a transient threshold, the following appear to be important quantities: the integral of the waveform, the peak amplitude, and the maximum rate of rise. Neither is it known whether these quantities are sufficient to characterize the transient threshold. An attempt has been made to incorporate these parameters into a draft EMP standard, which is currently under review.

Another difficulty arises from the many power and signal conductors that may be connected to an equipment unit. Even with only 20 conductors, a unit can be excited (and can fail) in 400 different wire-to-wire and wire-to-ground modes. Only a few may be important to electromagnetic interference considerations, but the method of determining which are important, and of controlling the design and manufacture so that only those are important, is yet to be determined. Current EMC standards specify a narrowband continuous-wave stress and a transient injected on the whole wire bundle or on a few selected wires, but the relation of the specified stress to system environments is not known.

In addition to interference conducted to a unit, the electromagnetic environment will induce surface charges and currents on the equipment enclosure. We must determine which distributions of charges and currents can induce the threshold response, how many of these distributions the external (or internal) source interacting with the system can induce, and which parameters are necessary to describe the induced charges and currents.

### 3. Barrier Specification.

A number of issues affecting specification of protection must be addressed. For example, we may have to distinguish between an interface requirement (within an environmental zone) and a barrier requirement (between two zones). The former is a compatibility criterion; the latter is an immunity or emission criterion. The effects of these requirements on system manufacture and procurement must be evaluated. Present EMC/EMI practices blur the distinction between interface and barrier requirements; for example, cable shields are sometimes not considered part of the electromagnetic barrier system.

Configuration control is another issue affecting the barrier specification. Because communication facilities are subject to frequent modifications, these facilities should be designed so that equipment location within the facility is relatively unimportant. For example, if EMP survivability is to be insensitive to equipment location, the barrier at the facility level must make the internal environment effectively independent of the EMP. On the other hand, the configuration of the facility-level barrier may have important ramifications on the reliability and maintainability of the barrier. The barrier that contains many joints, conduits, cable shields, connectors, and other components, is topologically the same as a simple, one-piece, facility-level shield; but the opportunities for failure or malfunction are much greater in the complex, multicomponent barrier.

### 4. Qualification Tests.

Test procedures to qualify components, subsystems, and systems must be specified, and to be meaningful, the test must be relatable to an operational environment. At present, this is very difficult and often impossible. Test techniques that can be traced to opera-

tional conditions must be developed, so that passing a test can ensure survival in a particular environment.

To achieve this goal, the interfering source must be carefully specified, and interaction mechanisms must be identified. The test source must be relatable to the actual source. One way to do this would be to simulate the actual source. However, simulating an external interference source is not sufficient to characterize the operational environment, because the source interacts with the facility structure between the source and the location of the equipment under test. Thus, the operational environment at the location of the equipment is quite different from the external environment. The deeper inside a facility a subsystem is located, the more difficult it becomes to analyze and describe accurately the interaction mechanism between the external source of interference and the subsystem in question. Fortunately, deep inside a facility, the most likely interference will come from the system itself rather than from an outside source (even a high-altitude EMP), and hence, the dominant sources would be system-generated transients.

The practical solution is to reduce external threats to levels below system-generated transients. This eliminates the necessity to simulate the interaction of external sources with the internal structure of the system.

Any C<sup>3</sup> facility generates transients from switching cyclic loads, motors, power conversion, etc. (see Part I, Appendix D). As mentioned above, deep inside a system, transients from these sources are very likely larger than those induced even by strong external sources. The system-generated transients would thus be the dominant stress at the unit level. To specify a meaningful test that can be related to an operational environment, we need to know the characteristics of those transients. At present, we have insufficient reliable data on system-generated transients. Further work is necessary to identify the principal sources of system-generated transients, to characterize the important properties, and to specify typical peak values of those transients.

If the system-generated noise is dominant, it can be used as the stress that units must tolerate. Although the system-generated noise can be controlled, it is not known how much control is reasonable. However, two conceptual limits for what constitutes reasonable control exist. No benefit will accrue if very stringent internal noise control is applied so that the outside source becomes the dominant stress. To verify continued system hardness in such a case, the system would have to be tested often with a test directly relatable to the external threat level. On the other hand, if exceptionally severe sources of internal transients are not controlled, excessive costs will be incurred for providing immunity to those few severe sources.

At present, no military standards or specifications exist that could be used to design an adequate test relatable to external sources of interference like EMP and lightning. At the facility level, MIL-STD-188-124 specifies practices and methods to be used in assembling a facility, but it specifies only a few system functional requirements; no test procedures at the system level are required or established. Facility qualification standards are needed to evaluate facility immunity to incident fields and to currents and voltages on external lines, cables, and waveguides. However, procedures may depend on the shape, location, and complexity of facility barriers, as well as on the fidelity of the simulation required.

At the rack level, tests are done in accordance with MIL-STD-461/462. These tests are not relatable to the external sources, because these sources interact with the rack through the facility structure. If the fields are at all significant at the rack level, they will be quite complicated. The same applies to transients on signal, power, and grounding conductors. Furthermore, all these stresses depend on the facility as well as on the source.

At the unit level, similar considerations apply, except that the complication is even greater, because there are now (at least) two levels of poorly defined interactions between the source and the unit.

Since we evidently cannot specify high-fidelity simulation at the rack or unit level, we need to find the best compromise; we also need to know what we are giving up when we make a compromise. Such a compromise will depend on barrier shape and complexity of a facility. In a very complex system with complicated barrier shapes, exposed cabling, and grounding systems, it is extremely difficult to understand the broadband, high-stress interaction of the facility with external transient sources. It would be difficult to devise an economical test to evaluate one such facility, let alone a family or variety of very complex facilities. The immunity of simple systems is more easily evaluated and tested.

In addition, an adequate test must provide an appropriate stress, and it must allow the unit to respond as it would in an operational setup. This means that all significant sources and loads to which the unit would normally be connected must be present (or simulated) in the test. Only the dominant excitation (cable currents and voltages) need be used, if it can be demonstrated that surface fields are insignificant. It is not practical to develop a separate test setup for each source condition (angle of incidence, etc.) and for each application of a unit. It has been suggested that some norm that bounds the set for all known applications and sources could be determined.



E. REVISION OF EXISTING SPECIFICATIONS.

As a first step toward a unified electromagnetic standard, specifications and practices need to be revised to remove the incompatibilities that presently exist. The ideal barrier cannot be achieved, but whatever steps that are taken toward the topologically closed barrier will be beneficial; any steps taken away from the ideal will be detrimental. We have discussed the most important practices that are incompatible with the closed barrier approach, namely the penetrating grounding conductor and the interrupted cable shield.

The revision of those standards that require incompatible practices is straightforward: change the practice to a compatible one. A bit more subtle are changes to those standards that merely permit incompatibilities. The NEC, for example, does not require any incompatible practice, but the way the code is implemented results in such practices. Because the NEC is enforced by local authorities that have jurisdiction, it may be difficult to revise it to eliminate incompatible practices (although it might be argued that the "advice" given by the NEC should contain explicit instructions that lead to compatible practices).

Part I commented on the inadequacy of shielding effectiveness measurements according to MIL-STD-285 and IEEE-PRP-299, and the need for alternate ways of performing such measurements. An alternative way of measuring the shielding effectiveness of enclosures has not yet been found. In view of the unimportance of diffusion it is questionable whether it is even necessary or desirable to make such measurements. To be sure, shielding effectiveness measurements are desirable to the extent that they can reveal flaws and imperfection in an enclosure. But a test must yield uniform results, regardless of who performs the test. Measurements performed in accordance with MIL-STD-285 do not fulfill that condition.

## II VERIFICATION OF NEW TECHNIQUES

### A. OVERVIEW OF EXPERIMENTS.

Laboratory experiments were performed at SRI in three areas: grounding practices, shield terminations, and aperture coupling. These areas appear to be the most important. Grounding practices can have a large impact on interference control, even though grounding per se cannot be used as part of a barrier, as explained in Part I. However, because poor grounding practices can defeat an otherwise excellent barrier, great care must be taken not to allow grounding conductors to penetrate barrier surfaces. To demonstrate the magnitude of the impact of a penetrating ground conductor, we compared a topologically proper ground and an improper one.

It is common practice to terminate the shield of a shielded cable in a pigtail. The shield is then either "grounded" at both ends, or at one end only. We have argued in Part I that the proper procedure is to close the shield; whether it is grounded or not has no direct effect on the performance of the barrier as an electrodynamic shield. We have now conducted a set of simple experiments to demonstrate that a "closed" cable shield is superior to an interrupted but grounded one.

Finally, we performed numerous experiments involving aperture coupling, particularly for apertures that are small compared to wavelength. Although further research in this area is needed, several conclusions have been reached (see Section II-D).

The importance of the experiments described below is not only in demonstrating and verifying the superiority of the new interference control techniques, but also in the fundamental nature of the experiments. It is rare to see results in the literature that deal with fundamental concepts; more often, one particular parameter is studied without controlling the experiment sufficiently.

### B. GROUNDING PRACTICES.

Broadband interference control is not achievable if grounding conductors penetrate barrier surfaces. To determine how much attenuation is lost if such a penetration is permitted, we designed a simple experiment to demonstrate quantitatively the superior nature of the topological ground. In Part I, Appendix C, we reported on similar experiments (conducted with a large shielded room) that compared a penetrating ground return (pigtail) with a topologically proper return. The measurements were done in the time

domain; we measured the peak voltage induced in the largest loop inside the shielded room by a transient applied to the outside of the shielded room. These measurements showed that the topological ground is preferable in the high-frequency regime. However, most barrier compromises appear to arise from low-frequency considerations. The present experiments were therefore designed to reveal the behavior of ground systems at frequencies below 100 kHz. CW signals were used instead of transients to obtain the necessary dynamic range.

A small die-cast instrumentation box was used to simulate an equipment enclosure. The box was approximately 15 cm long, 10 cm wide, and 8 cm high. Inside, an operational amplifier powered by a battery measured the open-circuit voltage induced on the wall by an interference source on the outside. Two configurations were tested (Figure 3). The first simulates a penetrating signal ground (Figure 3a); the measured voltage was set to 0 dB by definition. The second configuration simulates the topologically proper ground (Figure 3b); the voltage measured in this case was normalized to the one measured with the penetrating ground.

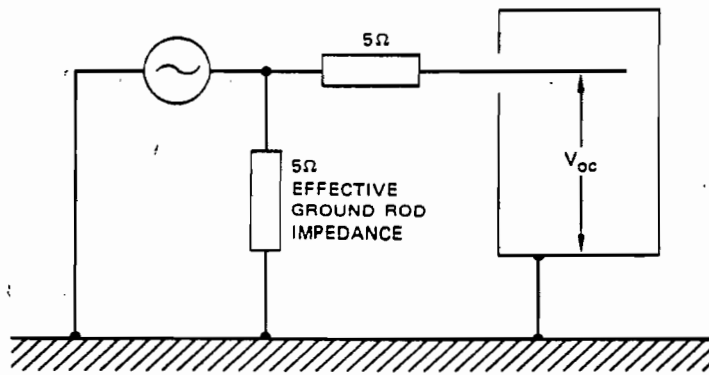

(a) PENETRATING GROUND

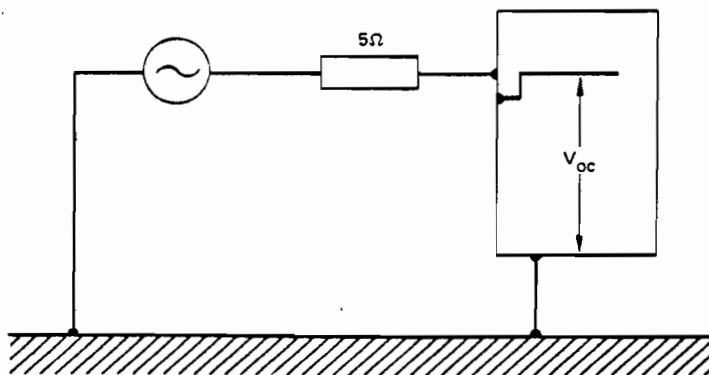

(b) TOPOLOGICAL GROUND

FIGURE 3 TEST SETUP (symbolic)

All measurements were performed with a substitution method. The dynamic range obtained was in excess of 140 dB. The operational amplifier had a very high input impedance. Therefore, the  $5 \Omega$  resistor in series with the amplifier can be neglected in the case of the penetrating ground; the resistor serves as a load for the current source in the case of the topological ground.

The results of the measurements are shown in Figure 4. As mentioned before, the penetrating ground voltage was set to 0 dB by definition. By comparison, the topologically proper ground gives an open-circuit voltage of -115 dB, even at the lowest frequency measured. Above about 20 kHz, the shielding inherent in the metal walls of the box begins to be effective. It is instructive to note that the topological ground is better even if there is a large aperture (without penetrations). Curve 2 in Figure 4 shows the same measurements as curve 1 but with the lid removed. At the lowest frequencies shown there is no difference in the open-circuit voltage induced inside the box. However, at the frequencies where the walls become effective as shields, the open aperture begins to show its effect. At frequencies above 100 kHz the effectiveness of closing the box can be seen in the difference between curves 1 and 2.

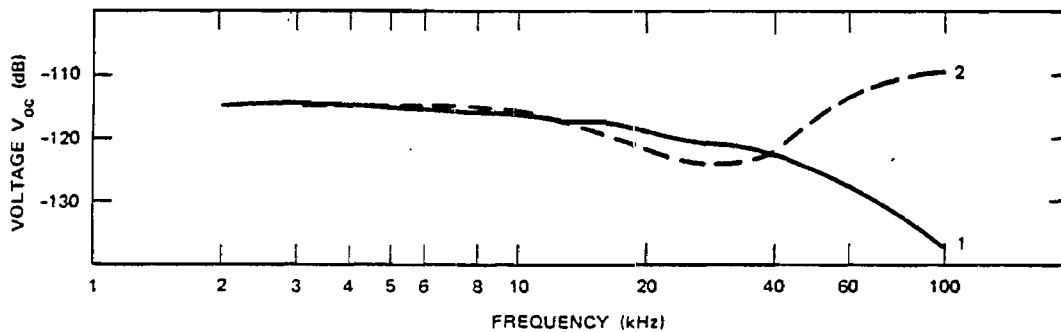

FIGURE 4 OPEN-CIRCUIT VOLTAGE  $V_{oc}$  AS A FUNCTION OF FREQUENCY. Setup as in Figure 3b. (1) box closed, (2) lid removed.

The exact level of the open-circuit voltage depends primarily on two factors. The first is geometrical: the voltage will be different if the measurement point is at a different location. We found a variation of up to 6 dB due to this factor. The other factor is the "ground rod impedance." We chose  $5 \Omega$  as being a representative impedance of a typical ground rod, although the impedance could be as low as  $1 \Omega$ , or higher than  $20 \Omega$ . The higher the impedance, the more important it is to use a topological ground system. However, even with a  $1 \Omega$  ground rod, the difference between the two ground systems is more than 100 dB.

The experiments were designed to explore differences in ground systems in the low-frequency regime. An extrapolation of curve 1 in Figure 4 shows that in the high-frequency regime the performance advantage of the topological ground is even larger than in the low-frequency regime where the margin is already more than 100 dB.

### C. SHIELD TERMINATIONS.

#### 1. Background.

The experiments described below were designed to demonstrate the effectiveness of a circumferential shield termination. The results also helped to explain why controversial practices, such as pigtailed, are effective in some applications but ineffective in others. In the topological view, cable shield is a continuation of an equipment enclosure barrier, and therefore the topologically proper termination is a circumferential connection of the cable shield to the equipment enclosure or entry panel. Many connectors are available that achieve a satisfactory circumferential bond.

In most practical cases involving interference propagated along cable shields, the situation can be described in a simplified way as follows. Two equipment units in metal enclosures contain circuits that are required to communicate with each other. The two units may be mounted in the same rack or a considerable distance apart. In any case, the interconnecting cables may be exposed to radiated interference from some source (EMP, lightning, system-generated transients), and a shielded cable is often used to prevent this interference from interacting with the circuits. The equipment enclosures are usually grounded to the rack or in some other way; however, depending on the separation, the two enclosures may not necessarily be at the same potential. If the cable shield is connected to both enclosures, a current would flow on the shield, which in turn could induce interfering currents on the core wires. Alternatively, a radiated field may interact with the loop formed by the cable shield, ground plane, and equipment enclosures and induce an interfering current on the cable shield.

This problem is generally recognized, and different techniques are used at present to solve it, depending on the frequency range of the interfering signal, or more often, depending on the operating frequency of the two interconnected units. At radio frequencies, the cable shield is grounded as often as possible to minimize the loop area, while at low frequencies, the cable shield is disconnected from one equipment unit to prevent the loop current from flowing.

We devised simple experiments to simulate this situation and to demonstrate the effects of different cable shield terminations. Two small instrumentation boxes made of die-cast aluminum were separated by a distance of 2 m and connected by a coaxial cable in

one case and a shielded twisted pair in the other case. We shall describe each of these experiments in turn.

## 2. Shielded Single Wire.

The test configuration is shown schematically in Figure 5a. We used an RG 62/U coaxial cable terminated by a resistor equal to the characteristic impedance of the cable. To drive an interfering current on the cable shield, a varying magnetic field could have been used to induce an emf in the loop consisting of the cable shield, the two boxes, and the ground plane. The alternate excitation would have been to inject a current into the ground plane such that the two boxes would be at a different potential. For simplicity, we chose to isolate one of the boxes from the ground plane and to inject an inter-

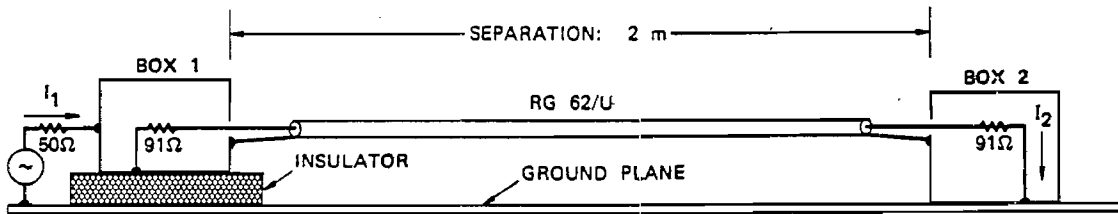

(a) TEST SETUP; CASE 2

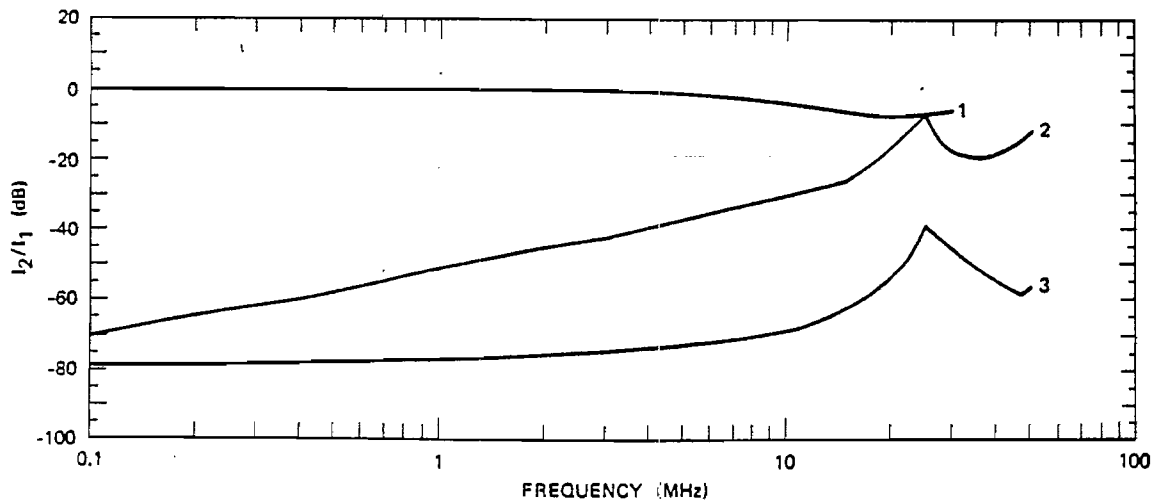

- (1) SHIELD TERMINATED AT ONE END ONLY (pigtail)
- (2) SHIELD TERMINATED AT BOTH ENDS (pigtail)
- (3) SHIELD TERMINATED AT BOTH ENDS (BNC connector)

(b) NORMALIZED CURRENT  $I_2$

FIGURE 5 EXPERIMENTS WITH COAXIAL CABLE (RG 62/U)

fering current directly onto Box 1, as shown in the figure. This mode of excitation is equivalent to the former two in that a current is excited on the cable shield. Therefore, any conclusions drawn from these experiments regarding shield terminations also apply to the case where magnetic fields interact with the loop and induce a shield current, or to the case where the two boxes are at different "ground" potentials.

We measured the current  $I_2$  inside box 2 and compared it to the driving current  $I_1$  in order to study the effectiveness of each termination. The ratio  $I_2/I_1$  is plotted against frequency in Figure 5b for three different shield terminations. The experiment was set up to demonstrate effects of the different terminations when the whole circuit is physically small compared to wavelength. As the separation between the two boxes approaches a substantial fraction of a wavelength, resonance effects are expected to occur. They will tend to obscure the underlying phenomenon being studied. We have included measurements at those frequencies to put the remainder of the data in proper perspective. Hence, a conspicuous feature in the figure is the resonance near 25 MHz.

If the shield is terminated at one end only (curve 1) the entire source current is forced to flow through the internal receiving circuit in box 2, i.e.,  $I_2 = I_1$ . This is true as long as the small capacitance between box 1 and the ground plane can be neglected, which appears to be valid for frequencies below 5 MHz. At those frequencies, the cable shield has no effect other than providing electrostatic protection. The same result would have been obtained with a magnetic field as the interfering source. While the interrupted shield would prevent an interfering current on the shield itself, the same emf would now be induced on the center conductor and cause an interfering current to flow. This fact is often not appreciated when a cable shield is isolated from an equipment enclosure in an effort to prevent an interfering current from flowing on the shield. There may be good reasons for interrupting such a current, but not for interrupting the shield, as will be seen shortly.

Curve 3 shows an  $I_2/I_1$  ratio of about -78 dB at frequencies below 5 MHz. That there is any measurable current  $I_2$  is due to leakage through the cable shield and to imperfections of the terminations and the two enclosures. The value of -78 dB therefore represents the best attenuation that can be achieved in this particular setup. Curve 3 is independent of frequency below 5 MHz. (The dynamic range of the measurement setup was about 120 dB.)

By contrast, Curve 2 is proportional to frequency within the range shown. This is explained by the additional coupling introduced by the two pigtailed, which can be inductive in nature for a range of load impedances.<sup>1</sup> This type of coupling is expected to be proportional to frequency. At a frequency of 10 kHz (extrapolated to the left in the figure), we would expect Case 2 to give an  $I_2/I_1$  ratio of -90 dB; however, it would be impossible to

achieve this value because of the limitations previously mentioned. Curves 2 and 3 actually meet at approximately 20 kHz; below that frequency, the two are indistinguishable.

An important conclusion can be drawn from these considerations. At audio frequencies, pigtailed are indistinguishable from closed shields (BNC connectors); however, at higher frequencies, closed shields are clearly superior to pigtailed as shield terminations. Thus, pigtailed could be used for circuits operating at low frequencies without any impaired performance, but only if there were no interference expected at high frequencies. In practice, this is almost never the case, because so many interference sources are transient and therefore broadband in nature. An argument often heard states that the circuit under consideration will not respond to interference outside its operating band. This may be true for very low-level interference, but it is becoming increasingly evident that solid-state devices are vulnerable to broadband transients (e.g., electrostatic discharges). The circuit designer must therefore take a broader view and include some high-frequency interference considerations even for a circuit operating at low frequency. The approach to interference control described in Part I provides a simple, yet effective tool to accomplish this goal.

### 3. Shielded Twisted Pair.

Experiments similar to those described above were performed with a shielded twisted pair replacing the coaxial cable (Figure 6). For these experiments, only the termination of Box 2 (the receiving end) was varied. In addition to the three basic variations — no termination, pigtail, and RF connector — we also included measurements with unbalanced and balanced circuits. The six different arrangements are shown in Figure 6a, with corresponding curves in Figure 6b.

The resonance effects again occur when the separation between the boxes approaches a substantial fraction of the wavelength. The interpretation of the results is essentially the same as before. If the shield is not connected to Box 2 (Case 1), all of the source current  $I_1$  is forced to flow through the receiving circuit in Box 2. A circuit analysis gives  $I_2 = 0.25 I_1$ , which corresponds to -12 dB (Curve 1). The pigtail terminations (Case 2 and 2A) show the same frequency dependence that was observed with the coaxial cable. Note that a pigtail terminated on the outside of the enclosure (Curve 2A) can be about 6 dB better than a pigtail carried into the enclosure (Curve 2). The curves for the pigtailed intersect the curves for the RF connector, and so the same conclusions are reached as before.

Experiments 1 through 4 in essence measured the common-mode current induced in the receiving circuit. If the load is balanced, as in Case 4, one could reasonably expect that the currents in the two branches are equal, at least to the degree the circuit can be



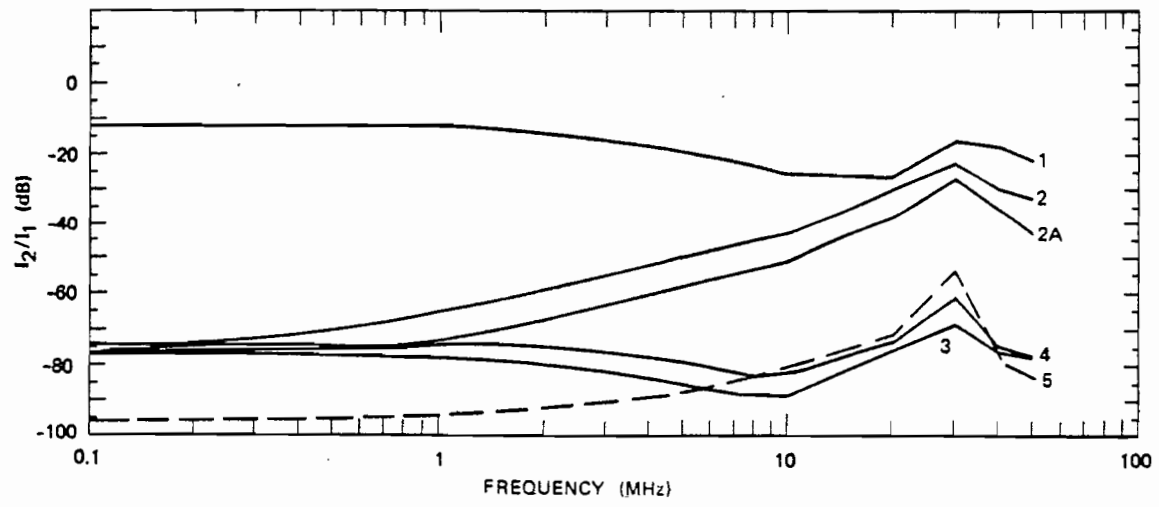
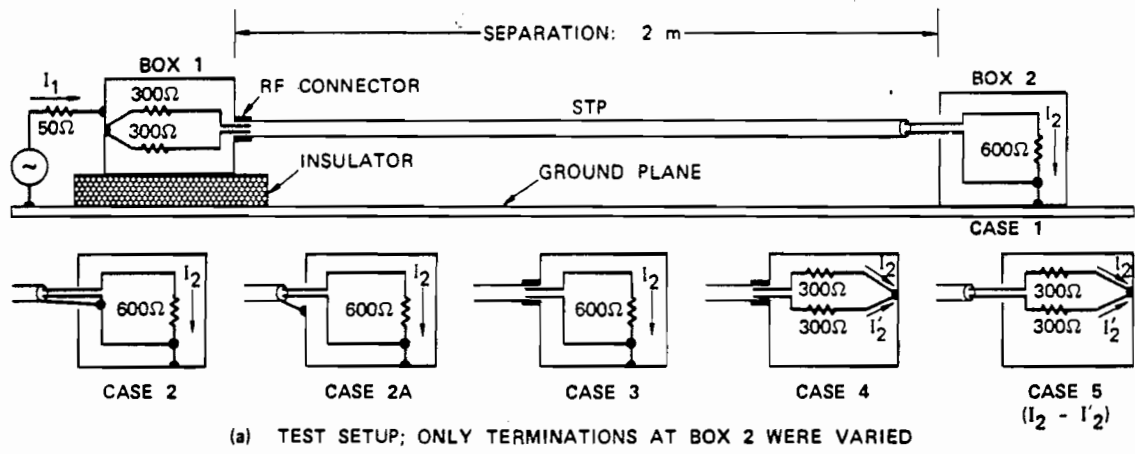

- (1) NO SHIELD TERMINATION
  - (2) PIGTAIL, INSIDE
  - (2A) PIGTAIL, OUTSIDE
  - (3) RF CONNECTOR, UNBALANCED
  - (4) RF CONNECTOR, BALANCED
  - (5) NORMALIZED DIFFERENTIAL CURRENT  
(no shield termination)
- (b) NORMALIZED CURRENT I<sub>2</sub> (Curve 5 shows the normalized differential current I<sub>2</sub> - I'<sub>2</sub>)

FIGURE 6 EXPERIMENTS WITH SHIELDED TWISTED PAIR

balanced. Curve 5 shows this differential current, without a shield termination. That is, Curve 5 should be compared to Curve 1. The figure shows that balancing the load is advantageous, even in the resonance region. At low frequencies, the difference between common mode and differential mode is well over 80 dB. In fact, compared to any of the unbalanced configurations that were tested (Curves 1 through 4), the balanced circuit offers 20 dB better performance, even without a shield termination. If the balanced configuration is combined with a circumferential shield termination, the difference between common mode and differential mode can be expected to exceed 100 dB.

Note again that the shielded twisted pair with the shield not terminated and an unbalanced load (Case 1) provides no advantage (beyond electrostatic protection) over a single wire with ground return.

#### 4. Conclusions.

The experiments underscore the importance of a circumferential cable shield termination. Topologically, a cable shield is a continuation of the equipment enclosure to which it is connected; the circumferential connection ensures the integrity of the barrier at the cable entry point. In addition, the experiments demonstrate that, although pigtailed are indistinguishable from a circumferential termination at low frequencies (audio), there is a dramatic difference in performance as the frequency increases above the audio band. Because so many sources of interference are broadband sources, such as system-generated transients, lightning, EMP, and electrostatic discharges, it is imperative that these effects be considered even when designing circuits and subsystems that operate at low frequencies.

#### D. APERTURE COUPLING.

If all wire penetrations of a shielded volume have been properly treated, the apertures on the exterior surface of the barrier can become significant points of entry for electromagnetic interference. These apertures may be in the form of holes or openings on the surface or in the form of seams and joints. Energy that enters through the apertures can interact with internal conductors to produce currents and voltages at equipment terminals. Figure 7 describes a general example of a volume containing wire penetrations and apertures.

To solve the aperture problem, the system designer must: (1) determine quantitatively the effects of the apertures on the internal voltages and currents, and (2) develop measures for "closing" those apertures that affect system performance. Aperture problems are closely tied to the problems involved with developing meaningful specifications, standards, and test procedures. What is required is a measurable performance criterion

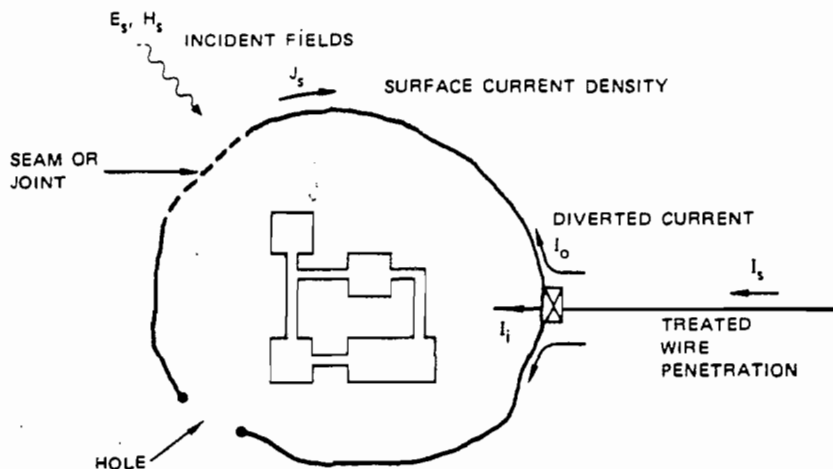

FIGURE 7 SHIELDED VOLUME WITH APERTURES AND WIRE PENETRATIONS

that can be related in a unique way to the effectiveness of the barrier surface in reducing the internal interference caused by external sources.

Several parameters exist for defining this measurable performance criterion for apertures:

- (1) Energy that enters the volume through the apertures.
- (2) Electromagnetic field distribution inside the volume as a result of the external interference sources.
- (3) Currents and voltages induced on conductors inside the volume by external interference sources.

For any of these options to be useful, both the electromagnetic coupling properties of the aperture and the susceptibility of the system elements must be expressible in terms of the listed parameters (i.e., energy, fields, currents, and voltages).

The general aperture coupling problem described in Figure 8 can be formulated in terms of any of these parameters, although an exact solution of the problem may be impossible to obtain for an actual system. The susceptibilities of the elements inside the volume include the concepts of both damage and upset thresholds. Damage thresholds for some system elements may be understood in terms of energy, but this is not applicable for many elements. For example, capacitor failure thresholds are generally a result of an over-voltage and cannot necessarily be expressed in terms of energy. Some semiconductor components have failure thresholds that can be directly related to energy, but these thresholds are not well defined statistically. Neither can susceptibilities be related directly to field quantities. Thus, it appears that the third parameter -- currents and voltages on

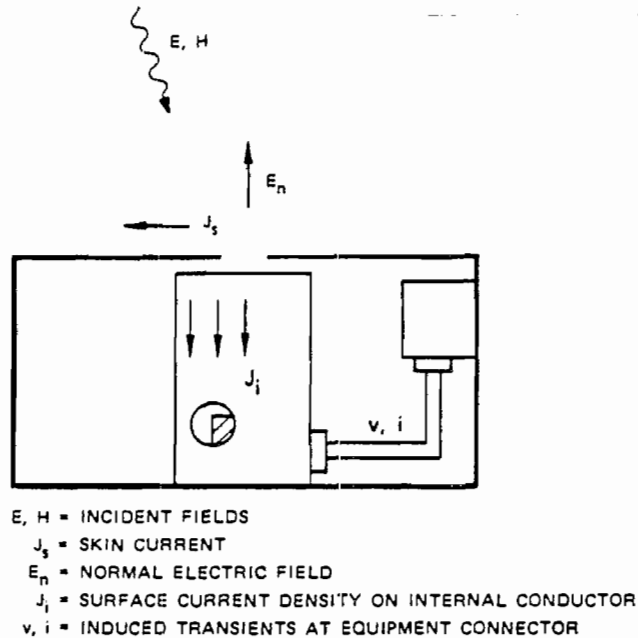

FIGURE 8 APERTURE COUPLING EXAMPLE

internal conductors -- holds the most promise for developing measurable performance criteria for a barrier surface.

The following paragraphs discuss the aperture coupling problem in more detail and relate the recent advances in the understanding of the problem to the development of meaningful specifications, standards, and test procedures.

#### 1. Theoretical Background and Implications.

The types of apertures encountered with typical facility shields are holes with maximum dimensions of a few meters, long narrow slots, or seams. For analysis purposes, these apertures can be considered "small," that is, the characteristic dimension is much smaller than a wavelength. Long narrow slots and seams are considered as distributed small apertures, and their coupling properties can be expressed per unit length. With the discussion being limited to "small" apertures as defined above, the following discussion of the theoretical background is generally valid for frequencies below 100 MHz. This is not a severe restriction, since the spectral content and coupling transfer functions appropriate for nuclear EMP and lightning are usually insignificant above 100 MHz.

Two recent publications<sup>2,3</sup> present excellent reviews of the literature describing aperture coupling. These problems are difficult to analyze, especially the case of an

aperture on a cavity containing equipment and wiring. The only configuration for which analytically rigorous results are available is that of a small circular aperture on a conducting plane of infinite extent. Numerically "accurate" results are available for some cavity and aperture configurations.<sup>3</sup> These were obtained by a numerical solution of integral equations in terms of the unknown aperture field components. The aperture fields were then considered as sources for the fields existing behind the aperture.

The mechanisms of field leakage through an aperture are described in Figures 9 and 10. The normal electric field and the tangential magnetic field couple through the aperture to interact with conductors and wiring loops behind the plane. As the figures imply, this coupling problem is equivalent to the problem of electric and magnetic dipole sources located at the aperture with the aperture shorted. These sources, radiating in the presence of the conducting plane, produce the same fields in the shadow region as do the

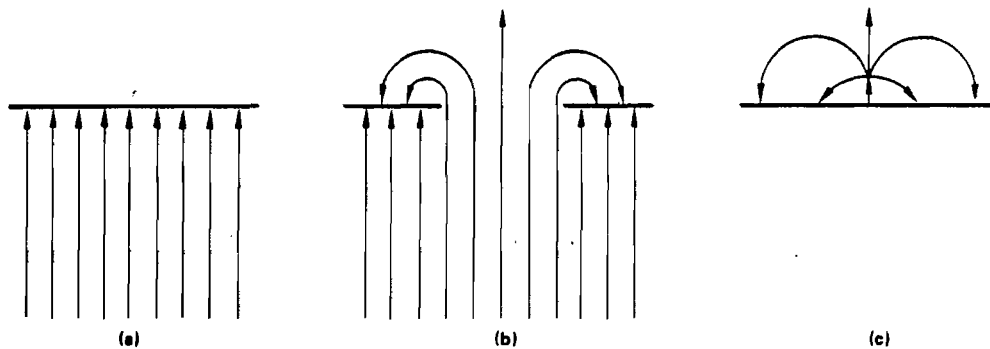

FIGURE 9 ELECTRIC FIELD APERTURE-COUPPING GEOMETRY. (a) Impressed electric field perpendicular to screen with no aperture. (b) Electric field near aperture in screen. (c) Equivalent electric dipole (on screen with no aperture) and its electric field far from aperture.

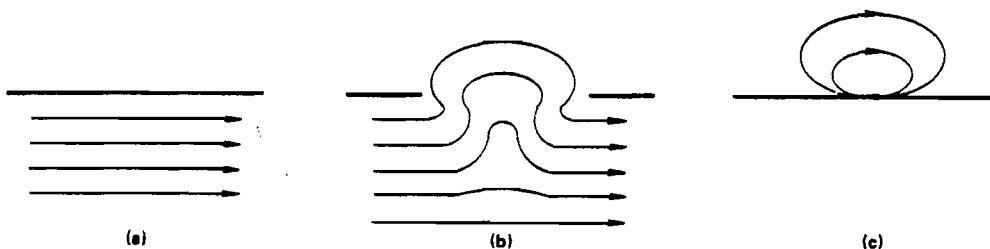

FIGURE 10 MAGNETIC FIELD APERTURE-COUPPING GEOMETRY. (a) Impressed magnetic field parallel to screen with no aperture. (b) Magnetic field near aperture in screen. (c) Equivalent magnetic dipole (on screen with no aperture) and its magnetic field far from aperture.

original external sources. Formally, the problem is reduced to finding the dipole moments of the equivalent sources and computing the fields produced by these sources.

The presence of a partially filled cavity behind the aperture provides further complications. For these more realistic geometries, the dipole moments must be modified to account for the effects that the cavity and the equipment inside have on the aperture fields. This is a very difficult problem for the general geometry of a cavity with apertures. Even if we could determine the modified dipole moments, the problem of calculating the existing fields inside the partially filled cavity still remains to be solved. For the types of partially filled enclosures normally encountered, this too is a very difficult problem.

a. Bounds on Transients Coupled to Single-Wire Circuits.

It is well known within the EMP community that it is impossible to predict with a reasonable degree of accuracy the transient voltages and currents induced on individual conductors inside a volume filled with equipment. The most recent research into this problem indicates that upper bounds may be able to be developed for these transients. A recent paper by Davis<sup>4</sup> develops expressions for bounds on the transients induced on a single terminated wire behind an aperture. The equivalent dipole moments of the aperture are bounded, the fields coupled to the wire are bounded, and the resultant voltage and current sources driving the wire-to-shield transmission line are bounded using relatively simple algebraic expressions.

Recent work by Casey<sup>5</sup> and by Hamm and Graf<sup>6,7</sup> has proposed and verified a quasi-static model for aperture coupling. An important outcome of this work has been the development of new measurements that are related directly to the aperture's coupling properties and that can be related to the upper bounds of induced transients.<sup>6,7</sup> The theoretical study by Casey indicated that a small circular aperture can be considered as an inductance, and that the voltage induced across the aperture by magnetic field coupling is the product of the inductance and the time derivative of the external surface current intercepted by the aperture. The measurements by Hamm and Graf verified this analysis. Figure 11 shows the external current driven over the aperture and the resulting voltage measured across the aperture on the inside of the test volume. The table in the figure indicates the accuracy of Casey's quasi-static model for the aperture sizes used in the experiment. The waveshape of the aperture voltage is very close to that of the time derivative of the external surface current. The test configurations used to obtain these waveshapes are described in the appendix.

Another important contribution of Casey's work is the development of a simple model for predicting the effectiveness of a mesh screen placed over the aperture. With the

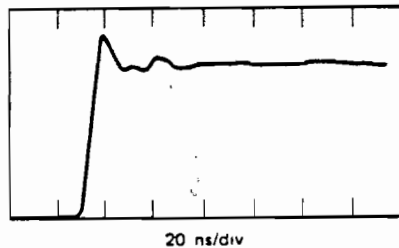

Peak  $J_s = 40 \text{ Am}^{-1}$   
 Peak  $\dot{J}_s = 6 \text{ Am}^{-1}\text{ns}^{-1}$

(a) SURFACE CURRENT DENSITY AT APERTURE

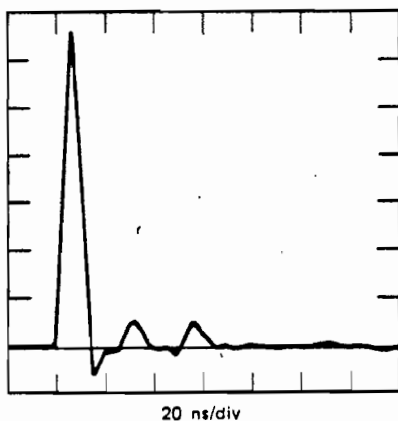

APERTURE RADIUS (m)	PEAK VOLTAGE (V)	
	MEAS.	THEORY
0.10	66.5	67.9
0.05	17.7	16.9
0.025	5.2	4.2

(b) VOLTAGE ACROSS APERTURE

FIGURE 11 EXTERNAL SURFACE CURRENT DENSITY AND INDUCED APERTURE VOLTAGE (waveshapes shown are typical)

untreated aperture modeled as an inductance, a wire mesh cover can be modeled as a parallel impedance element, as shown in Figure 12, where  $Z_{eff}$  is the effective impedance of the mesh. This impedance can be evaluated using the expressions developed by Casey. Measurements reported by Hamm and Graf<sup>6,7</sup> indicated that this model for mesh screens was successful in predicting the reduction in aperture voltage when the mesh was placed over the aperture. The table on Figure 12 describes the effectiveness of various mesh screens in reducing the aperture voltage and indicates the accuracy of Casey's model.

These quasi-static models are useful for a quantitative understanding of coupling through an aperture and are formally valid only for a circular aperture on an infinite ground plane. The formal extension to noncircular apertures backed by partially filled cavities is a difficult problem that has not been solved. Certain bounding statements can

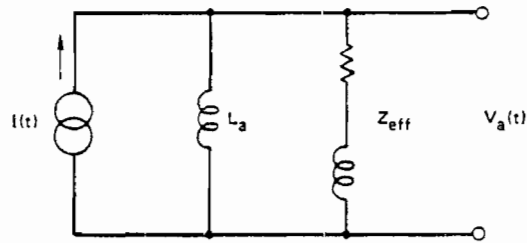

$L_a$  = EQUIVALENT APERTURE INDUCTANCE  
 $Z_{eff}$  = EFFECTIVE SCREEN (mesh) IMPEDANCE

APERTURE RADIUS (cm)	MESH SIZE (cm)	APERTURE VOLTAGE REDUCTION	
		PREDICTED	MEASURED
10.0	2.54	0.129	0.119
	1.27	0.064	0.043
	0.64	0.028	0.020
2.5	2.54	0.375	
	1.27	0.215	
	0.64	0.102	0.084

FIGURE 12 EQUIVALENT CIRCUIT FOR MESH-COVERED APERTURE WITH MEASURED AND PREDICTED APERTURE VOLTAGE REDUCTION FACTORS

be made, however, that relate to the usefulness of the results of the analysis of a circular aperture in an infinite plane. Both Casey and Davis state that the characteristics of noncircular apertures can be bounded from a knowledge of coupling through circular apertures, and that coupling through an aperture on an infinite plane is an upper bound on coupling to an aperture in a cavity.

What is needed next is a way to relate the quasi-static results for aperture voltage and displacement current to the transients induced on conductors inside the volume. The first step in understanding this problem is to consider a single wire, loaded at each end and situated behind the cavity. The aperture fields (or the equivalent dipole moments) are considered as sources that excite the loaded wire. This problem has been treated in a variety of ways,<sup>4,8,9,10</sup> and the basic approach has been to model the wire behind the aperture as a transmission line above a ground plane. The transmission line is excited by the fields from the equivalent sources at the aperture location. Figure 13 describes the geometry of the problem and the transmission line model used for analysis. Davis has shown that the voltage and current sources exciting the transmission line can be computed rather simply from a knowledge of the aperture polarizability and the surface fields at the aperture when the aperture is shorted.



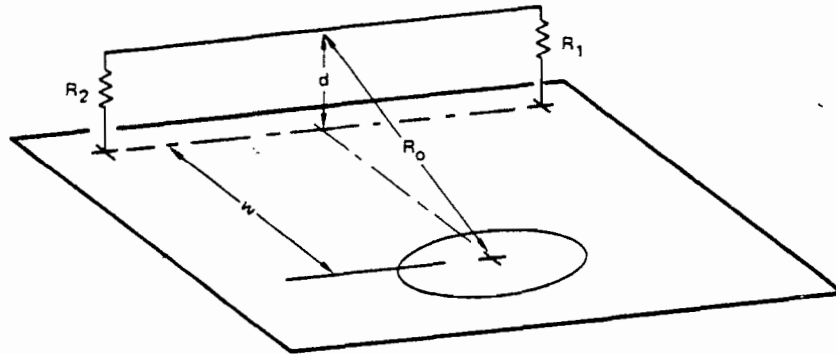

NOTE: This plane is infinite.

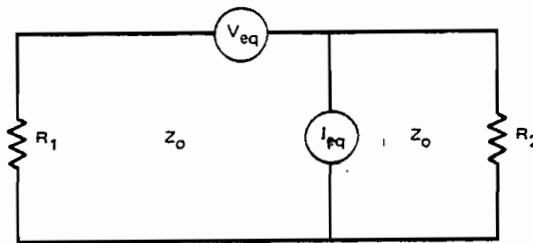

FIGURE 13 GEOMETRY OF WIRE BEHIND APERTURE AND TRANSMISSION LINE COUPLING MODEL

The transmission line model is formally valid only for wires that are at least an aperture radius from the center of the aperture. Davis makes the conjecture that his bounding expressions may also apply for wires closer to the aperture than this theoretical limit. This is an important point, since measurements very near the aperture have been proposed by Hamm and Graf<sup>6,7</sup>. Other proposals<sup>11</sup> suggest that the measurements be made outside of an exclusion volume about the aperture. In either case, the measurements must be relatable to the equivalent sources in the transmission line model, or at least to upper bounds of these sources.

The topic of upper bounds for transients induced on a single wire is discussed in more detail in the appendix to this report. The bounding expressions derived by Davis are compared to the results of experiments performed at SRI and elsewhere.

b. Bounds on Transients Coupled to Multiconductor Circuits.

Most practical examples of aperture coupling involve multiconductor receiving circuits rather than isolated single-wire configurations. The exact routing of any one wire in a

multiconductor bundle is never known, and the termination impedances are unknown and time-varying. Thus, transient voltages and currents on any one wire in the bundle cannot be predicted accurately. Recent analyses of this problem have used a matrix formulation and have developed bounds derived from matrix theory.<sup>12-14</sup> Wire bundles are modeled as multiconductor transmission lines, with the distributed inductance and capacitance modeled as matrices. Relatively simple expressions for bounds result from this analysis, and the bounds computed compare favorably with the results of an analysis of a well-defined canonical problem. The appendix discusses this approach to the bounding problem in greater detail.

## 2. Relationship of Apertures to EMP Specifications, Standards, and Test Procedures.

Recent laboratory experiments and theoretical analyses have provided a framework for understanding coupling through apertures to equipment wiring. The previous paragraphs have described the concepts involved in developing bounds for currents and voltages induced on wiring. These bounds include elements associated with the external sources, the size and shape of the aperture, the geometry of the receiving circuits inside the volume, and the termination impedances of the internal wiring. The connection between this work and the development of new standards is that it now appears possible to make aperture measurements that can bound the signals induced on internal wires.

The problem is now one of defining measurements that lead to upper bounds on transients. The model used by Davis and others -- dipole sources radiating in the presence of a multiconductor transmission line -- requires data that can be related to the equivalent dipole moments. The approach used by Baum<sup>11</sup> is based on the same coupling model, but proposes that the equivalent sources that drive the transmission line be determined by measurements. Since this coupling model is valid only for wires sufficiently far removed from the aperture, Baum proposes that an "exclusion volume" be considered to exist around the aperture. All measurements to characterize the aperture must be made with sensors located outside the exclusion volume.

Coupling to wires very near the aperture has been considered by Lee and Yang<sup>9</sup> by assuming that the dipole sources at the aperture are modified by the nearby wire. The analysis shows that the strength of the modified dipole source can be several times that of the unperturbed source for wires located closer than one hole diameter to the center of a circular aperture. The measurements by Hamm and Graf<sup>6,7</sup> of the aperture voltage and the displacement current were made with the sensors right at the aperture and can be related to the quasi-static model of Casey. These measurements are discussed in more detail in the appendix.

The problem of developing standards and test procedures for apertures has not been solved completely. The measurements discussed in the appendix can be used to predict upper bounds for wires near the aperture, but will be too conservative for wires distant from the aperture.

### III SPECIFICATION OF EMP PROTECTION

#### A. GENERAL.

To develop an EMP protection specification for a system, one must first have a systematic approach to interference control. Such an approach has been described in Part I and elsewhere.<sup>15,16</sup> As the name implies, however, a specification must deal with details (specifics) in a quantitative way. That is, we must be able to determine how much protection is needed, how many barriers are needed or desired, how the protection is to be allocated among these barriers, and the effects of barrier size, shape, location, and other design options. We must also be able to measure the success of the EMP protection, and we must be able to maintain the protection in its operating environment. Finally, all features of the EMP protection must be achieved in a manner that is compatible with other electromagnetic requirements on the system, such as lightning, EMI/EMC, COMSEC, etc.

Inherent in the ability to quantify and measure protection is the assumption that we can characterize and evaluate the EMP-induced stress and the system threshold at some points in the system. A great deal of the technical effort in the EMP community has gone into programs for analyzing system responses and developing simulators in which system responses can be measured (these techniques may be of limited use for designing new systems, because there is no structure to analyze and no hardware to test until the prototype has been designed and built). Thus, for existing systems we may determine an EMP-induced stress at some point in the system.

In addition we may test components, boxes, etc., in the laboratory and determine some threshold for malfunction, damage, or other unacceptable response. Unfortunately, the waveform for which the threshold is determined is rarely the same as the EMP-induced stress waveform. Hence, the simple concept of comparing the EMP-induced stress to the component threshold is, in fact, tedious to implement. To make this comparison, we must usually make some assumptions about how the stress is induced and propagated, and about the nature of the component malfunction or operation.

This section elaborates upon these issues with the goal of delineating the options and clarifying the characteristics and consequences of the protection choices.

B. ELECTROMAGNETIC COMPATIBILITY.

We will start with the simple system illustrated schematically in Figure 14. The system has an electromagnetic interior and exterior, and it contains units or subsystems, two of which are shown in Figure 14. There are interference sources at all interior levels — inside the system and inside the units. Let us assume that the sources inside the system are necessary accompaniments to the normal functioning of the system. Switching transients associated with power control and processing and with the operation of digital electronic circuits are examples of internal sources accompanying normal operation of the system.

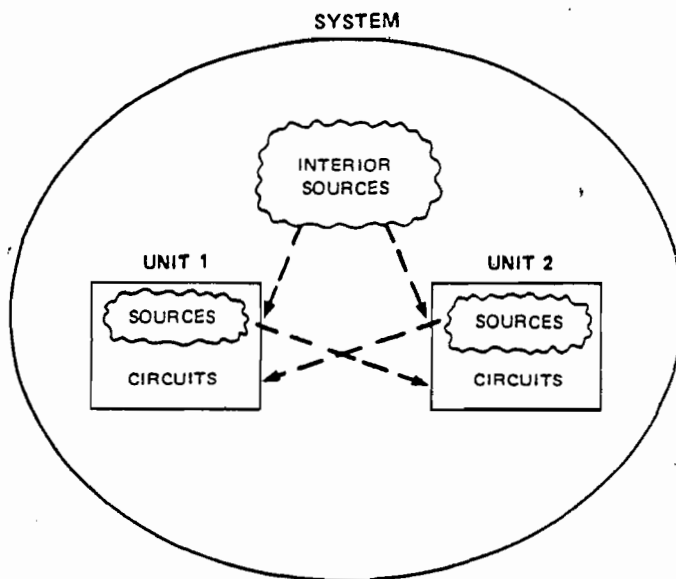

FIGURE 14 SYSTEM AND UNITS AND THEIR ASSOCIATED SOURCES OF INTERFERENCE

Let us first consider the electromagnetic compatibility requirements. The basic role of electromagnetic compatibility engineering is to ensure that units installed in a system will function harmoniously — that is, sources in one unit shall not adversely affect circuits outside the unit (including those in other units). Interunit compatibility is achieved by specifying a limit on the emissions produced by a unit. As discussed below, a limit on unit emissions is, alone, adequate to ensure interunit compatibility, provided the unit emissions are limited to an interference level that is small compared to the level generated by sources outside the unit.

The reason that the emission limit is adequate to ensure interunit compatibility is that all units must also have an interference tolerance that is specified on the basis of the system sources (see Figure 14). The tolerance, or susceptibility, requirement is that the circuits in the units shall not be adversely affected by system sources outside the units. Since the emission criterion for sources inside units is that they not contaminate the environment outside the units, a unit that tolerates its outside environment also tolerates the emissions of all other similarly specified units.

In both emission-limiting and system-generated interference protection, the electromagnetic barrier that separates the environment inside the unit from the system-level environment outside the unit is the unit case or housing and any filters, isolators, buffers, or common-mode rejection devices that may be used on power and signal lines. Therefore, in practice, the unit container and the treatment of the input/output leads form the protection required for electromagnetic compatibility and control of system-generated interference, and the quality of the protection is specified for both interference confinement (emission control) and tolerance (susceptibility). (The emission and susceptibility levels may be specified by MIL-STD-461/462, for example.)

It is interesting to note that, for electromagnetic compatibility and control of system-generated interference, the barrier nearest the source is used as the primary protection; that is, for unit emission control, in which the source is inside the unit and the protected space is outside the unit, the unit barrier is used to confine the source so that it does not contaminate the system (hence other units). Similarly, for control of system-generated interference, in which the source is outside the unit and the protected space is inside the unit, the unit barrier, which is the first barrier encountered on a course between the source and the protected region, is the functioning protection.

This protection philosophy was not consciously developed in the electromagnetic compatibility and protection arena, but its evolution was not entirely accidental. This approach is least dependent on understanding the detailed responses of complex systems to broadband interference. Understanding the responses of system circuits outside the unit to sources inside the unit is typically less difficult than understanding the responses of circuits in one unit to sources in another unit. In the first case, interaction through one barrier must be understood, while in the second case, interaction through two barriers and an intermediate volume must be understood. Since there are abundant reasons why the analysis and test of interaction through multiple barriers and complex system structure may be questioned, it is not surprising that the protection philosophy that assigns primary protection to the barrier nearest the offending source has evolved.

C. ALLOCATION OF EMP PROTECTION.

Consider now sources outside the system (Figure 15), such as EMP, lightning, or RF transmitters. The protection objective is to protect all system elements against adverse effects caused by these sources. Thus, we wish to protect elements of the system outside the electronic units, as well as circuits inside these units. Thus, we must provide a barrier at the system level to protect elements outside the units. We might also consider allocating some of the circuit protection to the unit barriers; however, if we do this we must develop a rationale for making the allocation. Therefore, let us examine the consequences of applying the protection at the nearest barrier.

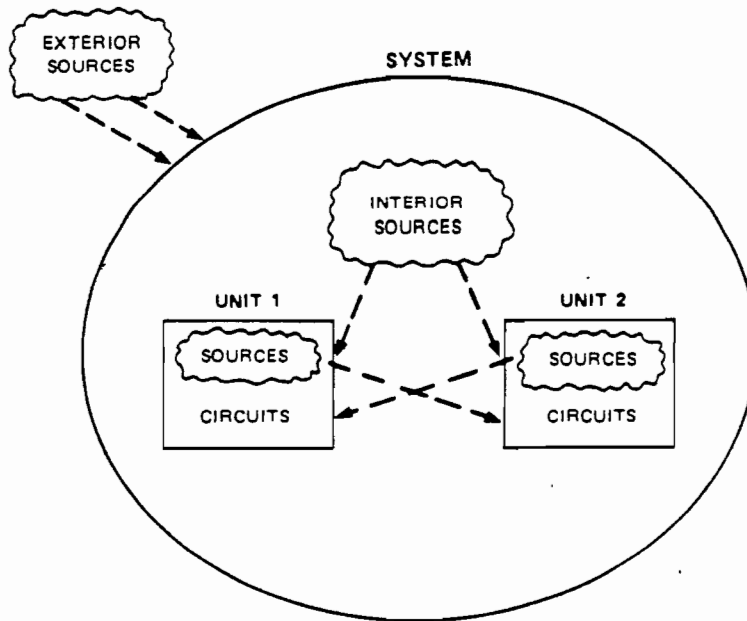

FIGURE 15 SYSTEM WITH EXTERIOR SOURCES

In progressing from the exterior source toward the system, the first barrier encountered (see Figure 15) is the system-level barrier. If the system-level barrier reduces the effects of the exterior source to a level that is small compared to that produced by interior sources, then the electromagnetic stress inside the system is determined by system-generated interference. No requirement directly related to external sources is placed on units or other interior elements of the system, and the designer of the unit is not required to provide protection against an external source interacting through an unspecified system barrier and interior structure.

Note that, topologically, this is the same requirement that was placed on the unit to achieve compatibility and immunity to system-generated interference. In each case, the protection unique to the source is allocated to the barrier nearest the source. In the interunit compatibility and in the protection against the exterior source, there are two functioning barriers between the source and a sensitive circuit inside a unit; therefore, an allocation has, in fact, been made. In this allocation, each barrier is required to reduce the effects of sources on one side to a level that is small compared to the effects of sources on the other side. Such barriers have been called "effectively impervious" because they ensure that the environment on one side of the barrier depends only on sources on that side of the barrier; that is, the environment on one side is independent of sources on the other side.<sup>17</sup>

In the case with two barriers, the barrier nearest the source ensures that the source does not contaminate the existing interference environment on the opposite side of the barrier. The second barrier ensures that this existing environment does not adversely affect sensitive circuits inside the units. Thus, both barriers have been allocated a protection role, but their protection role is determined by "visible" adjacent sources rather than by remote sources viewed through another electromagnetic barrier and a maze of system structure. Hence, by applying the nearest-barrier rule, we have achieved a rationale for allocating protection among multiple barriers. At the same time, we have achieved a protection system that is amenable to rigorous evaluation.

Some advantages of the effectively impervious nearest-barrier allocation are apparent from Figure 16. As illustrated in this figure, the EMP is the dominant stress only outside

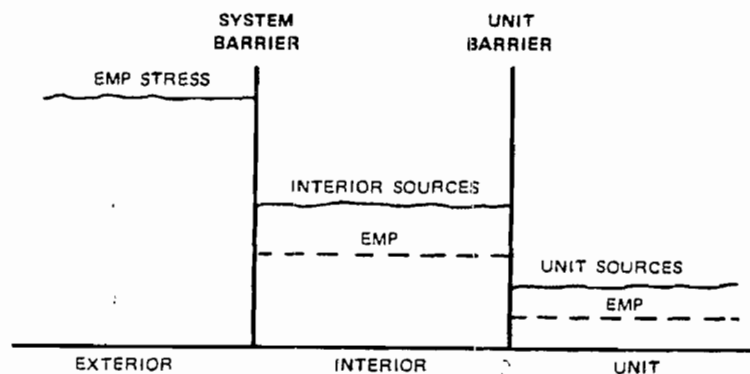

FIGURE 16 "FIRST BARRIER" ALLOCATION (only system barrier has EMP-unique requirement)



the system; inside the system, it is secondary to system-generated stresses. Thus, no unique EMP requirement is necessary for units or subsystems inside the system-level barrier; if these units can survive the normal system-generated environment, they can also survive the system environment with the EMP stress. Furthermore, configuration control is not required inside the first barrier to ensure system immunity to EMP. A corollary of this property is that modifications and equipment changes inside the first barrier do not affect EMP immunity if they do not alter the internal system-generated transient stress (and if the new equipment tolerates this stress). Initial validation and operational monitoring of system immunity are also straightforward, because all protection that is unique to EMP is associated with the system-level barrier; hence, only this barrier need be validated and monitored.<sup>18</sup> The system itself routinely tests the interior structure and units with transients that are stronger than the EMP-induced stress.

These properties are particularly important for EMP protection, because the system does not experience the EMP during normal peacetime operation. Thus, unlike other stresses whose effects are felt routinely, the EMP stresses are only felt during a grave national emergency. It is important, therefore, that the EMP not stress the sensitive elements of the system to levels never before reached, because these may be elements of the systems on the verge of failure that will fail if the stress is slightly larger than normal. In addition, it is important that EMP immunity not depend on the configuration of internal wiring, equipment layout, and other characteristics of the facility that change frequently with maintenance and modification.

#### D. CHARACTERIZATION OF INTERNAL ENVIRONMENT.

In spite of the importance of the system-generated environment to intrasystem compatibility and interference immunity, surprisingly little data on this environment have been published (and some that have been published contain the effects of external sources inextricably mingled with the effects of internal sources). Some speculation has been made on the character of system-generated transient interference inside the first barrier (see Appendix D in Part I, and Reference 19), and unpublished data on system environments tend to support the conclusion that peak transient voltages of the order of one to ten times the peak supply voltage can be expected inside a facility that has not been specifically treated to make it "quiet." Thus, it is important to recognize that the system-generated transient environment is not necessarily a particularly benign environment. Note also that the system-generated environment is a variable in the determination of the effectively impervious condition, as well as in system interference control. If strong sources such as the inductive kicks from solenoids and relays are suppressed with diodes or filters, the transient environment inside the system can be made rather weak, thereby making the effec-

tively impervious criterion more severe. On the other hand, it has been suggested that consideration could also be given to installing a transient source in the system to deliberately generate a strong ambient environment inside the first barrier -- perhaps stronger than the system itself would normally produce. Whatever internal environment is deemed appropriate, it seems clear that the properties of this environment must be understood and controlled better than they have been in the past. And even though this environment is not EMP-dependent, it does affect the amount of EMP protection required at the first barrier (as well as the amount of protection required to establish unit interference emission and susceptibility levels).

As noted earlier in this section, the EMP-induced stress and the unit or component threshold determined from bench tests usually do not have the same waveforms. Hence, we must devise schemes for comparing dissimilar waveforms to estimate the effect the EMP-induced stress will have on a unit or component. For effectively impervious EMP barriers, the system-generated transient stress is the facility threshold. Unsatisfactory performance is stipulated to be an EMP-induced stress that exceeds the largest system-generated stress, and as with other threshold/stress comparisons, we must devise a scheme for making the comparison.

Baum<sup>20</sup> has considered the problem of scaling imperfect simulator environments to the threat criterion for various conditions, such as differences in waveform (or spectrum), test object and simulator interaction, etc., for linear interactions. For nonlinear interactions, little guidance is available in the literature. Nevertheless, many system responses are nonlinear, and it is important that possible nonlinear responses be accounted for in comparing EMP-induced stresses to system-generated stresses. In addition, if we are to determine whether an EMP-induced voltage waveform is more or less severe than a dissimilar system-generated voltage waveform at the same point, we must understand how the system might react to each.

Some characteristics of a waveform that appear important are:

Rate of Rise -- Mutual coupling of the form  $Ldi/dt$  and  $Cdv/dt$ , and loop and dipole responses,  $dB/dt$  and  $dD/dt$ , depend on the rate of rise or rate of change of the wave. Hence, system responses that depend on mutual coupling will depend on the first derivative,  $d/dt$ , of the waveform.

Peak Value -- Insulation strength and some digital circuit responses depend on the peak value of the voltage or current wave.

Impulse Value -- The responses of many digital circuits and some sluggish linear circuits depend on the impulse values,

$$\int_0^{\infty} v dt \quad \text{or} \quad \int_0^{\infty} i dt \quad ,$$

of the wave.

Rectified Impulse -- Some nonlinear circuits "stack" oscillatory waves in such a way that their response depends on the rectified impulse:

$$\int_0^{\infty} |v| dt \quad \text{or} \quad \int_0^{\infty} |i| dt \quad .$$

Action -- Energy-dependent responses (damage) depend on the action of the wave:

$$\int_0^{\infty} v^2 dt \quad \text{or} \quad \int_0^{\infty} i^2 dt \quad .$$

Other characteristics may be important in special circumstances -- some frequency-selective circuits may be affected by the frequency of the dominant oscillatory stress wave, but we are not aware of this having been observed in any of the system tests conducted to date. It is also conceivable that derivatives of higher order than first could be important, but we are not aware of cases in which they have been important to EMP protection or EMC.

If we assume that the five parameters above adequately describe the EMP-induced stress and the system-generated transient stress, then the EMP barrier is effectively impervious when these parameters are larger for the system-generated transients than they are for the EMP-induced transients just inside the EMP barrier and at all other points inside the barrier. This places an additional condition on the EMP barrier; namely that the rate of rise (or bandwidth) be bounded in such a way that internal wiring and structure exhibit quasi-static behavior.

The rate-of-rise or bandwidth limit on the EMP-induced stress inside the EMP barrier is necessary to preclude momentarily enhanced voltages or currents, such as those observed in the aperture experiments, where the loop voltage was momentarily twice the induced voltage. As illustrated in Figure 17, we desire the EMP-induced voltage to be approximately the same throughout the length of internal cables, so that the condition

$$\text{EMP Stress} < \text{System-Generated Stress}$$

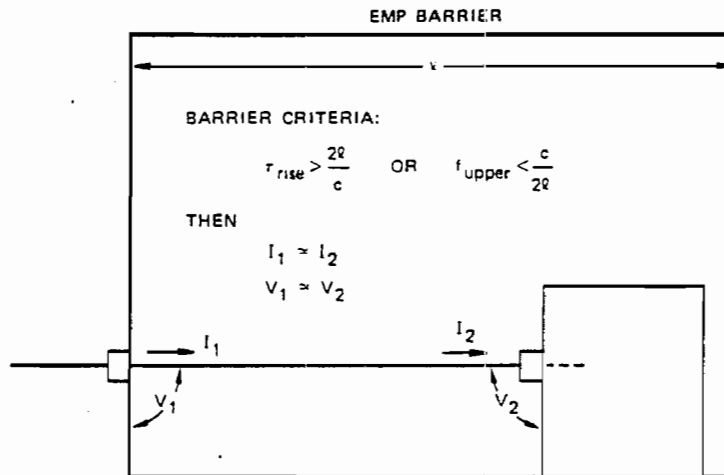

FIGURE 17 LIMIT ON RATE OF RISE OR BANDWIDTH INSIDE EMP BARRIER

holds everywhere inside the EMP barriers if it is true just inside the barrier. Thus, for the rate-of-rise parameter, the EMP barrier must satisfy two conditions:

$$\begin{array}{ccc} \text{Rate-of-Rise} & < & \text{Rate-of-Rise} \\ \text{(EMP)} & & \text{(System-Generated)} \end{array}$$

and

$$\tau_{\text{rise}}^{(\text{EMP})} > \frac{2\ell}{c}$$

where  $\ell$  is a characteristic length, such as the longest interconnecting cable length, and  $c$  is the speed of light.

Without this bandwidth condition on the EMP, both the EMP-induced stress and the system-generated stress inside the barrier could exhibit standing waves (or their time-domain equivalent) of such a nature that determining the dominance of system-generated stress at one point in the system would not ensure its dominance everywhere inside the barrier. Note, on the other hand, that imposing the bandwidth limit on the EMP-induced stress ensures that (1) the EMP-induced transients do not exhibit the standing-wave effects, and (2) if the EMP-induced parameters are smaller than the system-generated parameters, the system-generated parameters important for the comparison also do not

exhibit standing wave effects (although the system-generated stress may contain spectral components outside this band that do exhibit standing wave effects).

The bandwidth limit also implies that a penetrating conductor (such as that illustrated in Figure 17) must be treated with low-pass or band-pass filters to limit the high-frequency spectrum entering the facility. Furthermore, since coupling through apertures tends to emphasize the high-frequency spectrum, aperture coupling must be carefully evaluated and controlled. Fortunately, aperture coupling tends to be considerably smaller than penetration on insulated wires, but even so, if the apertures are large, abundant, or if internal wiring is close to the aperture, aperture coupling can be important.

If the bandwidth limit is met, we can compare the EMP and system-generated stresses at the inside surface of the EMP barrier. At the barrier, the EMP-induced stress can be represented as a Thevenin equivalent voltage source, as illustrated in Figure 18a. This voltage will cause a current  $I_{EMP}$  to flow through the system impedance  $Z_s$ . When this same circuit is excited by a source in the system, as illustrated in Figure 18b, a current  $I_{SG}$  will flow in the same system impedance  $Z_s$ . It is stipulated that if all important aspects of  $I_{SG}$  are more stressful than the corresponding aspects of  $I_{EMP}$  at the test point just inside the barrier, then the system-generated environment is dominant at that point and at

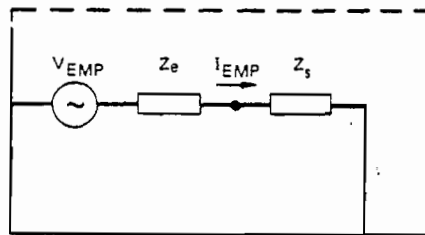

(a) EMP EXCITATION

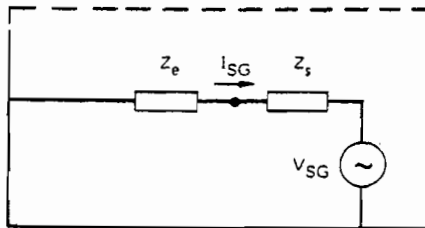

(b) SYSTEM EXCITATION

FIGURE 18 COMPARISON OF EMP-INDUCED CURRENT TO SYSTEM-GENERATED CURRENT

all other points inward along the conductor path. The extension of this model to multiconductor cables can be made by letting  $V$  and  $I$  be vectors and the impedances be matrices.

The use of the currents for the comparison is advantageous on two counts: (1) currents are usually more easily measured than voltages, and (2) it need not be assumed that  $Z_e$  is linear (as it often is not). That is,  $Z_e$  in Figure 18b need not be the same as  $Z_e$  in Figure 18a for the comparison  $I_{EMP} < I_{SG}$  to be valid. On the other hand, the arguments above do presuppose that the system impedance  $Z_s$  remains constant. This assumption may not always be valid, because it is some switching action that produces most of the system-generated transients.\* Although these switching actions usually have a large effect only on the circuit switched, it is advisable to use the assumption of a constant  $Z_s$  cautiously. In addition, the EMP excites all parts essentially simultaneously, but the system-generated stress from different sources may excite different parts differently; that is, one source could produce a stress larger than the EMP-induced stress at one point, while a different source produces the larger stress at another point. The system meets the criterion that system-generated stress is dominant at each point, but it may not be dominant at all other points inward from the EMP barrier.

---

\*The authors are indebted to G. Schlegel for pointing out these problems.

## IV RECOMMENDATIONS FOR SPECIFICATIONS

### A. INTRODUCTION.

As noted in Section III, interference control is achieved with the least demanding barrier effectiveness criteria and is least dependent on understanding the wideband response of complex system structures and circuits if the barriers are effectively impervious, so that the transient stress on one side of the barrier is not dominated by sources on the other side of the barrier. If the barrier is less effective than this, the stress produced by a source, such as EMP, will be dominant inside the outermost barrier and perhaps even inside the equipment case, and one is obliged to understand the response from dc to 100 MHz of all structure and wiring entering into or affecting the EMP response inside and outside each barrier. This is a formidable task that is never really completed in assessing practical facilities; hence, the risk that some important responses have been overlooked or incorrectly analyzed is always present.

For the allocation and barrier effectiveness that leads to a two-level, effectively impervious barrier system, all requirements directly related to the EMP, lightning, and other external sources are confined to the outermost barrier (facility level), and only requirements for intrafacility compatibility are imposed on the boxes, cabinets, etc., that form the second-level barrier. Hence, EMP qualification and surveillance are required only at the facility-level barrier, and no EMP requirements are imposed directly on internal configuration control or on the boxes themselves, although by measuring the effectiveness of the facility barrier against the system-generated transient levels, we are indirectly placing requirements on the boxes and interior cabling and structure.

Currently used standards and specifications at the box level are:

MIL-STD-461	Electromagnetic Interference Characteristics, Requirements for.
MIL-STD-462	Electromagnetic Interference Characteristics, Measurement of.

Those at the facility or system level are:

MIL-E-6051	Electromagnetic Compatibility Requirements, System.
MIL-STD-188-124	Grounding, Bonding and Shielding.

MIL-E-6051 is intended for use in procuring airborne systems and vehicles, although Air Force ground systems are apparently also within its scope. MIL-STD-188-124 is intended for use in procuring and installing ground-based telecommunications equipment and facilities.

Although many other standards and specifications are used to procure components, control manufacturing processes and finishes, etc., the above box and system standards ultimately set tolerances for interference and determine the electromagnetic environment in facilities. Therefore, if adequate standards are developed for unit emission and immunity to transients and for facility-level protection against external transient sources, there need be no concern over component and process standards. Component and process standards appear to be adequate at present, even though they may permit (but do not require) undesirable processes and procedures.

#### B. FIRST BARRIER -- SYSTEM OR FACILITY PROTECTION.

The EMP protection roles of the first barrier are to:

- (1) Reduce the EMP-induced transients to a level that is small compared to system-generated transients.
- (2) Limit the penetrating conductors and apertures to a number that can be thoroughly analyzed and tested to evaluate their EMP response.
- (3) Provide a single closed surface that contains all of the EMP protection components and can be monitored and maintained easily.

These requirements of the first barrier should be stipulated in a system or facility standard that specifies the requirements of the barrier and specifies the electromagnetic environment inside the barrier. The system standard should also specify the methods to be used to verify success in meeting the protection requirements.

Neither MIL-E-6051 nor MIL-STD-188-124 adequately fulfill these functions. MIL-E-6051 identifies many subjects that should be considered -- such as lightning tests, static electricity, selection of test points, and electrical power -- but it does not specify how tests shall be conducted or what levels are acceptable. Instead it delegates authority for establishing these conditions to an "electromagnetic compatibility control board," an entity whose creation is required by the specification. All technical detail is required to be included in a "control plan" that includes management structure, workforce, and other nontechnical matters, as well as antenna coupling, corrosion control, etc.

MIL-STD-188-124, on the other hand, specifies in considerable detail how grounding systems shall be designed and installed and how bonds shall be made and shields constructed. This standard neither prescribes a quality of environment inside the facility nor an acceptance criterion for the facility. One test that is specified is the method of measuring the resistance of the grounding electrode.



Furthermore, it appears that the EMP protection requirements identified above also apply to protection against any external source of electromagnetic interference. That is, the system-level barrier is required to protect its internal components against lightning, power line transients, external transmitters, and other sources, as well as the EMP. In addition, the environment inside this barrier must be one that the internal equipment can tolerate -- it must be compatible with the immunity and emission requirements specified in MIL-STD-461/462 or its successor. At present, there is no documented requirement on the system integration activities (government or contractor) to provide a system-level environment that equipment meeting MIL-STD-461/462 will tolerate. Conversely, there is no evidence that equipment meeting the requirements of MIL-STD-461/462 will tolerate the system environment resulting from satisfying MIL-E-6051 or MIL-STD-188-124.

In an effort to fill this need for a system-level environment requirement, a draft standard is being prepared. The draft standard will be limited to EMP protection, but it could easily be extended to lightning and other external sources by changing the test waveforms. The proposed goals of the draft standard should include, but are not limited to the following:

- (1) Specify an upper limit on the EMP-induced stress inside a facility.
- (2) Limit the number of penetrations whose responses must be understood.
- (3) Limit the bandwidth or rate of rise of penetrating transients, so that comparisons just inside the EMP barrier are valid throughout the interior of the facility.
- (4) Prevent EMP-induced stress from being the dominant stress inside the EMP barrier, so that the EMP responses of all internal circuits need not be understood.
- (5) Allocate protection so that a high-performance EMP shield is not required.
- (6) Eliminate the need for configuration control inside the facility to maintain EMP immunity.
- (7) Eliminate the need for EMP requirements on internal equipment (hence no "EMP stock" required in inventory).
- (8) Accommodate validation, acceptance, and surveillance testing.

The draft standard will achieve these goals by using the allocation of protection described in Section III-C. The essence of this allocation is that the units and cabling inside the structure must tolerate the system-generated transient environment (a peacetime requirement without consideration of EMP) and that the EMP barrier must reduce EMP-induced currents and voltages to below the system-generated voltage and current transients. However, to control the rate of rise and other EMP-induced quantities, the standard will actually specify the maximum EMP-induced parameters inside the barrier and will require

that the corresponding system-generated parameters be larger than the EMP-induced parameters.

A requirement of the standard will be that a minimum level of system-generated transient activity be established inside the facility to distribute protection uniformly between the EMP barrier and the units, yet maintain subordination of the EMP-induced stress inside the facility. A maximum level of system-generated transient activity is only vaguely specified in the draft standard, although such a requirement is needed to ensure acceptable peacetime operation of the facility. That is, the system-generated transient activity should be bounded on both the low side and the high side. The low-side bound need not be as rigid as the high-side bound, however, because the requirement for a minimum level is that the minimum be reached occasionally -- say, once a day -- while the high side requirement is that the maximum stress never be exceeded.

The draft standard will not specify how the EMP barrier should be designed. Rather, it will specify how the barrier will be evaluated, and will place an upper limit on the number of conditions that can be evaluated by analysis or by local tests. If this number is exceeded, a full system illumination with above-threat fields and direct injection on cables and power lines is required for all system states and modes of excitation. The standard will also permit the EMP barrier to be made up of as many subbarriers as desired, but it will require that the EMP-induced responses of all electrically conducting elements of the facility be thoroughly evaluated for all regions in the facility where the EMP-induced stress is the dominant stress. Choice of the hardening option will be left to the system designer.

Because the protection allocation requires that the EMP-induced stress inside the EMP barrier be subordinate to the system-generated stress, no EMP requirements are necessary inside the first barrier and, in particular, no EMP requirements are needed on units of communication electronics equipment.

#### C. SECOND BARRIER -- EQUIPMENT CASE.

As noted above, no EMP requirement is levied directly on the equipment inside the EMP barrier, because the EMP-induced stress is not permitted to be the dominant stress inside the EMP barrier. An indirect requirement is that the equipment must tolerate the maximum system-generated transient stress, and this maximum is greater than the minimum, which in turn is greater than the allowable EMP-induced stress. Whether the immunity requirements of MIL-STD-461/462 are adequate is not known, because (1) it is not known how these requirements are related to the system-generated environment, and (2) it is not known how the system-generated environment that will be required in the draft EMP standard is related to the environment in current operational facilities.

Although we do not have much explicit data on system environments (in spite of the fact that this is the environment MIL-STD-461/462 is qualifying equipment to operate in), the system-generated stresses that will be specified in the draft EMP standard will approximate those found in many operating facilities today (see Appendix D in Part I). If this is the case, the draft standard will merely formalize and control what usually already exists, but has heretofore been rather loosely controlled.

The requirement on units operating inside the facility is that they tolerate this controlled, system-generated environment. To the extent that MIL-STD-461/462 ensures that the units will tolerate the facility environment, no new requirement on units is necessary. The numerous examples of interference and compatibility problems in the course of developing systems suggest that qualification to MIL-STD-461/462 does not ensure that the unit will function in a(ny) system. This is partly because the system environment is not adequately controlled and partly because the qualification requirements in MIL-STD-461/462 are not representative of the system environments.

In the long run, it will be necessary to modify MIL-STD-461/462 to incorporate more broadband (transient) requirements in the qualification tests. Such requirements would be necessary even if EMP were not a consideration because of the wide use of digital circuits with small operating levels -- these circuits are particularly susceptible to system-generated transients and are not adequately tested by the present edition of MIL-STD-461/462.

With EMP as a consideration, the requirement is that the unit tolerate the peacetime system or facility environment, but, in addition, that this facility environment must be more severe than the EMP-induced environment. Hence, there is a limit on accommodating susceptible equipment by making the facility environment benign. Although this places an indirect EMP requirement on the units, they are regularly exposed to the system environment, and the user is quickly made aware of any shortcomings in the unit's ability to meet its required tolerance for transients. Hence, shortcomings in MIL-STD-461/462 are much less serious than the shortcomings in the system standards and specifications, as far as EMP protection is concerned.

## V RECOMMENDATIONS FOR FUTURE WORK

The research performed under this program has clarified many of the issues that affect the specification and design of systems that can survive exposure to the nuclear EMP. This clarification of the issues has been accompanied by a better definition of those areas where further research, development, or industry consent is required. In this section we discuss some of these areas and propose approaches for resolving the issues in question.

### A. ALLOCATION OF PROTECTION.

Work during this phase of the standards program has identified the technical features of the hardening options. These options are described in terms of different allocations of protection to the system-level barrier and box- or unit-level barriers and of different shapes and construction of the barriers. What remains to be resolved are (1) the economic issues (relative cost), for which few data currently exist, and (2) better technical definition of the bounds and the methods of specifying these bounds.

Cost data are difficult to acquire without actually designing, constructing, operating, and maintaining several systems using each of the several allocation options, specifying the same performance requirements for each, and carefully accounting for all the marginal costs associated with each. Even under these conditions, personal and corporate biases and idiosyncrasies in the procurement specifications are likely to affect the costs almost as much as the hardening allocation, so that the generic cost of hardening may be difficult to evaluate even when several systems have been developed and made operational; certainly cost data based on hardening a single facility can be highly distorted.

An alternative to conducting such a cost "experiment" is to design for minimum overall cost. This was the basis of the "effectively impervious barrier" allocation; it requires no modifications of equipment inside the EMP barrier, it requires no configuration control inside the EMP barrier, EMP maintenance and surveillance are limited to the EMP barrier, and the EMP barrier need not be of extremely high quality. It was therefore postulated that the initial cost of the effectively impervious barrier might be less than the cost of a single system-level shield that provides all the protection, and the maintenance and surveillance costs would be much less than for the distributed-stress allocations. The effectively impervious barrier allocation makes use of the fact that equipment in a system must tolerate a fairly harsh peacetime environment in contrast to the single system-level barrier, which credits the equipment with no immunity to transients. However, because the

EMP-induced stress is not the dominant stress inside the effectively impervious EMP barrier, it is not necessary to monitor, maintain, control the configuration of, or understand the EMP response of the wiring, structure, and equipment inside the barrier, as is required for the distributed-stress allocations.

These advantages are achieved at the expense of understanding and controlling system-generated interference.

#### B. SYSTEM-GENERATED ENVIRONMENT.

The use of system-generated transients as the bound in determining the amount of protection required offers several benefits that have been discussed elsewhere. However, to realize these benefits, we must (1) know what the system-generated transients are, and (2) be able to characterize them in such a way that they can be compared to EMP-induced transients.

At present, there are few data on system-generated transients that can be used for system hardening design. In Appendix D of Part I, we deduced some transients that can be generated inside typical facilities. Most experimental data that have been published in the literature appear to be mixed; no distinction is made between transients generated inside the facility and those generated outside the facility. Only those generated inside the facility are of interest in bounding the EMP protection. Therefore it appears likely that additional data on system-generated transients must be obtained from experiments dedicated to measuring these transients. Such experiments could be performed as a part of other experimental programs, such as assessment, site survey, or validation tests.

Among the properties of system-generated transients, the following are of interest:

- (1) What are typical values observed?
- (2) How pervasive are these transients -- are they observed on all internal wiring, or only on certain power leads?
- (3) What are the principal sources of these transients?
- (4) What should the transient environment be inside the EMP barrier (considering the fact that existing sources can be excluded, or new sources can be added)?

#### C. CHARACTERIZATION OF TRANSIENTS.

When we attempt to determine typical values for system-generated transients, we are faced with a new problem -- how to characterize the transients so that we can compare them with each other or with EMP-induced transients. To answer this question we must speculate about how the system or its components respond to an electromagnetic stimulus. Certainly some system elements respond to the peak value of a voltage or current transients; other

elements, however, respond to the rate of change, the integral (impulse), or the energy. Since there are many different transient waveforms generated in the system by different sources, or generated at different points in the system by one source, it is important that some common means of characterizing the transients (other than completely defining each waveform) be developed.

Although the immediate reason for developing a means of characterizing transients is that the system-generated transients must be compared to the EMP-induced transients to define an effectively impervious EMP barrier, the need is more general than this. Since equipment thresholds are rarely determined with the EMP-induced stress waveform, almost all comparisons of EMP-induced stress and susceptibility threshold (however defined) require comparison of the system response to two different waveforms. Hence, characterization of transient waveforms, so that the effects of different transients on system response can be evaluated, is an important undertaking regardless of how protection is allocated.

So far we have identified five parameters to define the properties of transients. These are the maximum rate of change, the peak value, the impulse, the rectified impulse, and the action integral. However, we suspect that other parameters may also be pertinent. For example, the frequency of oscillatory waves may be important in some system responses. Further study of possible system responses is required to define the important response parameters.

#### D. MAINTENANCE AND SURVEILLANCE.

An important aspect that is unique to EMP survivability engineering is the maintenance of EMP immunity once it is achieved. Almost all other aspects of the system are tested routinely by mere use of the system. The EMP immunity would only be tested in the event of nuclear war (at which time a shortcoming would be disastrous), unless some surveillance procedure is invoked. Thus, the user routinely obtains feedback on the proper functioning of all aspects of the system, except its EMP immunity. The objective of a surveillance program is to provide feedback on the EMP immunity.

There are many ways of achieving this feedback on EMP immunity, ranging from performing a continual assessment of hardness throughout the life of the system, to performing an occasional "push-to-test" exercise with a built-in, barrier-monitoring system. They differ in cost, downtime or other interference with operations, complexity, reliability, and other measures. Because of its importance to maintaining operational immunity to the EMP, the surveillance and maintenance issues need to be more clearly defined and addressed in a manner consistent with that applied to the protection itself.

#### E. GENERALIZED STANDARDS.

The draft EMP standard, which is in preparation, will be limited to EMP, but the same principles used to develop this standard could be used for a standard on protection against general external sources of electromagnetic phenomenon. To generalize the standard, however, it is necessary to identify and characterize the sources of all external threats. This would include lightning, switching transients on power lines, magnetotelluric currents, precipitation and dust charging phenomena, radio and radar transmissions, earth gradients near power lines, and many others. Since the characteristics of many of these sources are not well known, we decided to limit the applicability of the standard to the high-altitude EMP. The method of protecting against external sources is general, but the amount of protection required and the test used to verify the protection is different for each source.

Nevertheless, it would be desirable to generalize the standard so that only one system-level, electromagnetic-effects standard is required for all threats. The generalization would, as suggested above, consist primarily of defining the characteristics of the other sources, incorporating them into the requirements, and devising tests for evaluating the candidate's ability to meet the requirements. The effort required to generalize the system-level standard could be extensive, however, because little effort has been made in the past to characterize these sources.

In addition, further effort may be required to develop a equipment-level standard that is consistent with a system-generated transient environment and that tests the boxes in a manner that is relatable to the operating conditions for the box. One way of achieving the equipment standard would be to revise MIL-STD-461/462 to incorporate system-generated stresses into the requirements and to revise the test methods to make the test results relatable to operating conditions. However, there is probably less urgency in obtaining a new box-level standard than in obtaining a general system-level standard. Because the system itself tests the boxes, if they are found wanting, the operators will be aware of it, whereas if the system or facility protection is lacking, it may not be detected until lightning strikes or war breaks out.

#### F. PREPARATION OF DESIGN GUIDELINES.

Well written standards are terse and precisely written, but it is not always clear from the standard alone how the requirements of the standard can be met. For this reason, most standards are accompanied by handbooks or design guidelines that explain how to design the facility to meet the requirements of the standard. Such design guides tend to be state-of-the-art interpretations of the requirements of the standard. For example, the design guide might offer several ways of handling penetrating conductors to meet the EMP

barrier criteria; in addition, it might suggest several acceptable ways of limiting the number of penetrations. Although the designer is not obliged to use any of the methods proposed in the design guide, it is important that he have access to these options, because they give him a feeling for what is considered an acceptable design approach. Without the design guide information, the designer may develop elaborate and costly designs to meet a restrictive interpretation of the requirement, whereas, in fact, a simple, inexpensive design would be adequate.

The handbook or design guide that accompanies a standard should, of course, be consistent with the standard, if it is to clarify the standard and not confuse the users. A handbook for the proposed draft standard would thus be constructed around the effectively impervious barrier and the subordination of the EMP-induced stress inside the EMP barrier. Hence, methods of calculating the EMP-induced stress deep inside the system or predictions of component damage due to EMP-induced transients would not be compatible with the draft standard.



## REFERENCES

1. C. R. Paul, "Effect of Pigtailed Crosstalk to Braided-Shield Cables," IEEE Trans. Electromagnetic Compatibility, Vol. EMC-22, pp. 161-172 (August 1980), UNCLASSIFIED.
2. C. M. Butler, Y. Rahmat-Sami, and R. Mittra, "Electromagnetic Penetration Through Apertures in Conducting Surfaces," IEEE Trans. Electromagnetic Compatibility, Vol. EMC-20, No. 1 (February 1978), UNCLASSIFIED. Also as Interaction Note 308 (same authors) "A Review of Electromagnetic Penetration through Apertures in Conducting Surfaces for EMP Applications", (15 August 1976).
3. K. S. H. Lee, editor, "EMP Interaction: Principles, Techniques, and Reference Data," EMP Interaction 2-1, Air Force Weapons Laboratory Report AFWL-TR-80-402 (December 1980), UNCLASSIFIED.
4. W. A. Davis, "Bounding EMP Interaction and Coupling," IEEE Trans. Antennas and Propagation, Vol. AP-29, No. 6 (November 1981), UNCLASSIFIED.
5. K. F. Casey, "Low Frequency Electromagnetic Penetration of Loaded Apertures," IEEE Trans. Electromagnetic Compatibility, Vol. EMC-23, No. 4 (November 1981), UNCLASSIFIED.
6. J. Hamm and W. Graf, "Electromagnetic Coupling Through Small Apertures," SRI International, Contract No. DNA 001-79-C-0206, Research Memorandum 5, SRI Project 8411 (30 November 1981), UNCLASSIFIED.
7. J. Hamm and W. Graf, "Electromagnetic Coupling to Loaded Loops Through Small Apertures," SRI International, Contract No. DNA 001-79-C-0206, Research Memorandum 6 (10 February 1982), UNCLASSIFIED.
8. D. Kajfez, "Excitation of a Terminated TEM Transmission Line Through a Small Aperture," Interaction Note 215, Air Force Weapons Laboratory, Kirtland Air Force Base, New Mexico (July 1974), UNCLASSIFIED.
9. K. S. H. Lee and F. C. Yang, "A Wire Passing By a Circular Aperture on an Infinite Ground Plane," Interaction Note 317, Air Force Weapons Laboratory, Kirtland Air Force Base, New Mexico (February 1977), UNCLASSIFIED.
10. C. M. Butler and K. R. Umashankar, "Electromagnetic Excitation of a Wire Through an Aperture-Perforated Conducting Screen," IEEE Trans. Antennas and Propagation, Vol. AP-24, No. 4 (July 1976), UNCLASSIFIED.
11. C. E. Baum, "Concerning the Scientific Basis for Noise and Interference Control," IEEE/URSI/NEM Joint Symposium, University of New Mexico, Albuquerque, New Mexico (24-28 May 1982), UNCLASSIFIED.
12. W. A. Davis and M. K. Sistanizadeh, "Bounding Signal Levels at Terminations of a Multiconductor Transmission Line Behind an Aperture," Interaction Note 412, Air Force Weapons Laboratory, Kirtland Air Force Base, New Mexico (June 1981), UNCLASSIFIED.
13. W. A. Davis and M. K. Sistanizadeh, "Frequency Domain Upper Bounds for Signals on Multiconductor Transmission Line Behind an Aperture," IEEE Trans. Antennas and Propagation, Vol. AP-30, No. 4 (July 1982), UNCLASSIFIED.

14. M. K. Sistanizadeh and W. A. Davis, "Time-Domain Upper Bounds for Signals on a Multi-conductor Transmission Line Behind an Aperture," IEEE Trans. Antennas and Propagation, Vol. AP-30, No. 6 (November 1982), UNCLASSIFIED.
15. C. E. Baum, "Electromagnetic Topology: A Formal Approach to the Analysis and Design of Complex Electronic Systems," Interaction Note 400, Air Force Weapons Laboratory, Kirtland Air Force Base, New Mexico (September 1980), UNCLASSIFIED.
16. E. F. Vance, "Electromagnetic Interference Control," IEEE Trans. Electromagnetic Compatibility, EMC 22, pp. 319-328 (November 1980), UNCLASSIFIED.
17. W. Graf and E. F. Vance, "Topological Approach to the Unification of Electromagnetic Specifications and Standards," Proceedings of the IEEE National Aerospace and Electronics Conference, Dayton, Ohio (May 1982), UNCLASSIFIED.
18. E. F. Vance, "EMP Hardening Maintenance and Surveillance," Technical Note, SRI Project 4107, Subcontract DC-SC-1026-3 to Contract F29601-82-C-0027 (Draft March 1982), UNCLASSIFIED.
19. E. F. Vance, "System-Generated Transients," Interaction Note 414, Air Force Weapons Laboratory, Kirtland Air Force Base, New Mexico (May 1982), UNCLASSIFIED.
20. C. E. Baum, "Extrapolation Techniques for Interpreting the Results of Test in EMP Simulators in Terms of EMP Criteria," Sensor and Simulation Note 222, Air Force Weapons Laboratory, Kirtland Air Force Base, New Mexico (20 March 1977), UNCLASSIFIED.

Appendix

BOUNDS ON APERTURE COUPLING

I. INTRODUCTION.

Figure A-1 shows the general aperture coupling problem of interest for electromagnetic interference control. An external electromagnetic field is assumed to be incident on a volume containing electronic equipment and wiring. The volume is assumed to be enclosed by a metallic surface containing holes and seams. The interaction of the incident field with the outer surface produces a surface current density  $J_s$  and a normal electric field component  $E_n$  at the apertures. These surface fields couple through the aperture to produce transients on conductors inside. The internal transients may be in the form of (1) surface current densities on equipment enclosures or (2) voltages and currents on exposed equipment wiring. The internal surface current densities  $J_i$  can interact through apertures on the enclosures with conductors at the next topological level, and the voltages and currents can drive these inner levels directly.

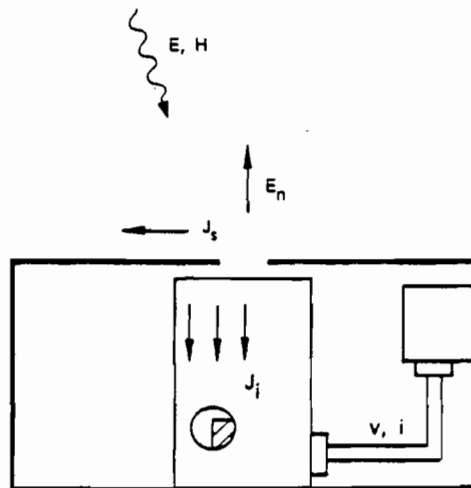

- E, H = INCIDENT FIELDS
- $J_s$  = SKIN CURRENT
- $E_n$  = NORMAL ELECTRIC FIELD
- $J_i$  = SURFACE CURRENT DENSITY ON INTERNAL CONDUCTOR
- v, i = INDUCED TRANSIENTS AT EQUIPMENT CONNECTOR

FIGURE A-1: APERTURE COUPLING EXAMPLE

The practical problems of interest usually concern volumes that are rather densely packed with equipment and wiring, where the wires are often routed in harnessed bundles. These coupling problems cannot be solved rigorously because of the complexity of the internal configuration of wires and conducting surfaces. Recent research into this problem has concentrated on determining upper bounds on the internal transients, and significant progress has been made in the past few years. Davis<sup>4</sup> has investigated bounds on coupling through an aperture to a single-wire circuit loaded at each end, and other work has addressed the more important multiconductor problem.<sup>12,13</sup> Both problems are formulated in the same way. The aperture excitation is modeled by the usual electric and magnetic dipoles radiating at the aperture location with the aperture shorted, i.e. closed. The single-wire and multiconductor circuits are modeled as transmission lines above a ground plane, with impedance loads at each end. The transmission lines are driven by the fields of the equivalent dipole sources, and this excitation is modeled by inserting equivalent voltage and current sources in the transmission line. Figure A-2 describes this model, a key requirement of which is that the circuit be separated from the aperture by at least a few aperture radii.

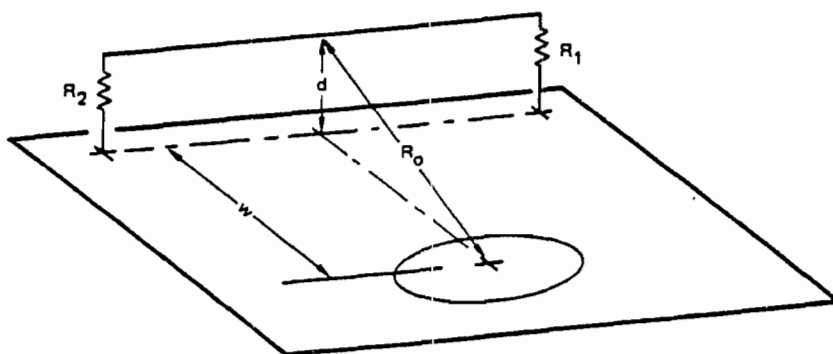

NOTE: This plane is infinite.

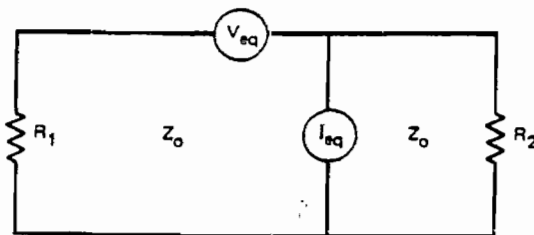

FIGURE A-2: GEOMETRY OF WIRE BEHIND APERTURE AND TRANSMISSION LINE COUPLING MODEL

The dipole moments can be bounded by bounding the aperture polarizabilities, and the induced currents and voltages can be bounded by applying the usual transmission line equations to the receiving circuit. For the single-wire receiving circuit, the mathematics is straightforward. Analysis of the multiconductor circuit requires a matrix formulation to generate bounds. The single-wire case is a special case of the more general matrix formulation.

Aperture coupling experiments performed as part of this contract have investigated coupling to circuits very near the aperture, as well as circuits distant from the aperture.<sup>6,7</sup> The results of these experiments can be used to check the theoretical results. The following sections of this appendix describe the measurement configuration and compare the measured currents to the upper bounds predicted by the theory.

## II. APERTURE COUPLING MEASUREMENTS.

The experiments performed at SRI are described in detail in two earlier research memoranda<sup>6,7</sup> and are summarized briefly here. A metal box was constructed with dimensions of 1.22 m by 1.83 m by 0.91 m. The box was excited by a parallel plate transmission line with a source and a matched load at the two ends of the line, as shown in Figure A-3. The upper surface of the box was designed so that a variety of apertures could be located under the upper plate of the transmission line. This excitation resulted in a field distribution at the aperture as shown in Figure A-4. The source driving the parallel plate line is shown in Figure A-5. This pulser circuit supplied an incident electric field with a peak value of 18 kV/m, with a risetime (zero to peak) of about 10 ns, and a pulse duration of approximately 8  $\mu$ s (to 1/e of the peak). Figure A-6 shows the electric field in the center of the parallel plate region.

Several test configurations were investigated in these experiments, but only those measurements that relate to the theories on bounding of the internal transients are discussed in this appendix. A single wire was inserted in the test volume in the configuration shown in Figure A-7. The dimensions W and D were varied, and the wire currents were measured under a variety of loading conditions. When the wire was short-circuited at each end, the observed current waveshape was similar to the waveshape of the incident electric and magnetic fields. When the wire was terminated in the characteristic impedance of the wire-to-surface transmission line (approximately 240  $\Omega$ ), the current observed on the wire had a waveshape similar to the derivative of the incident (external) fields. Figure A-8 displays these measured currents for one set of wire locations. The tables in the figure contain the peak amplitudes of the currents for two values of the parameter W and for a range of values of the parameter D.

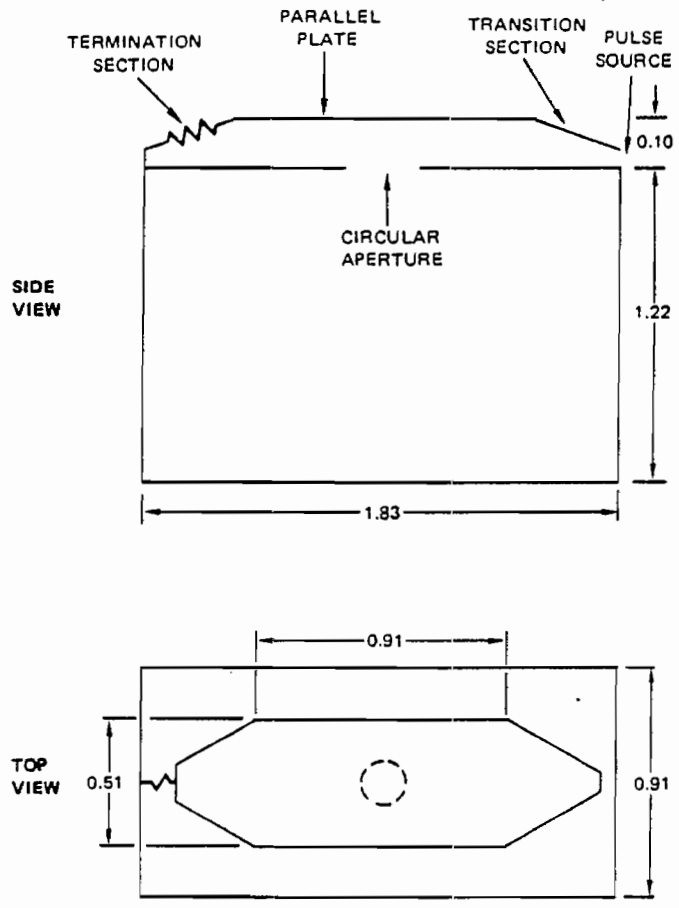

FIGURE A-3: TEST CONFIGURATION (all dimensions in meters)

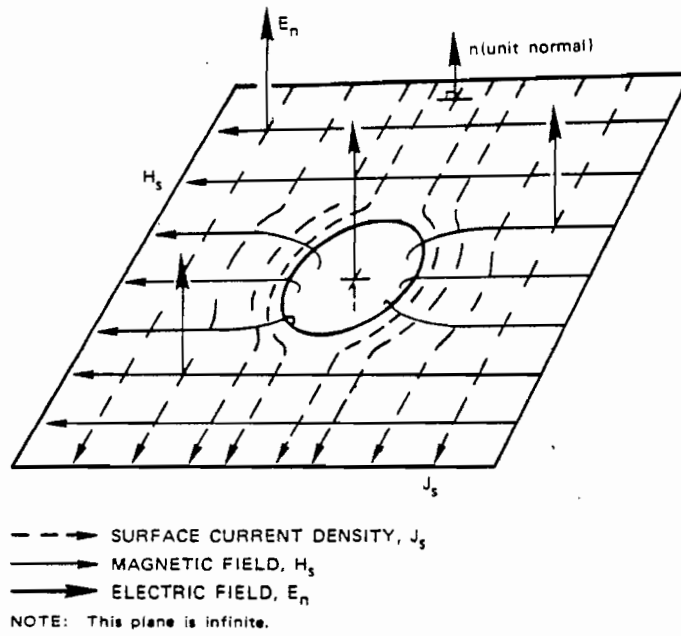

FIGURE A-4 FIELD VECTORS AND SURFACE CURRENT AT APERTURE

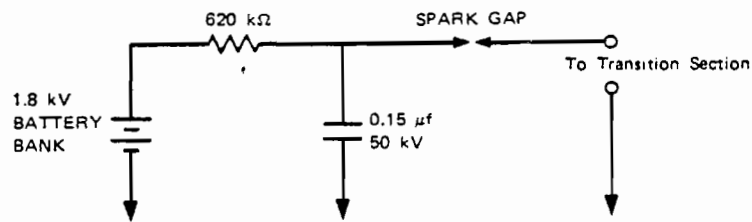

FIGURE A-5 PULSE SOURCE FOR PARALLEL PLATE REGION

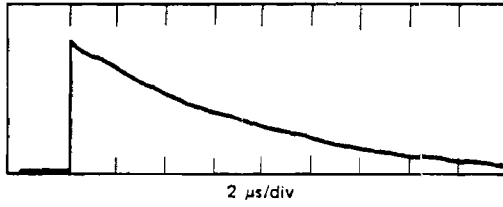
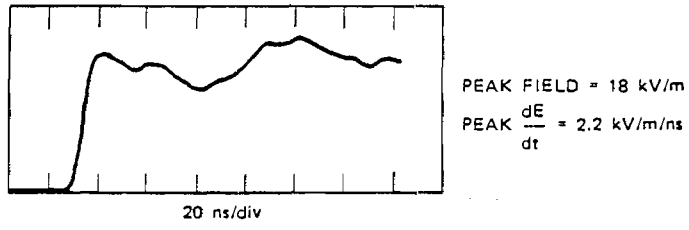
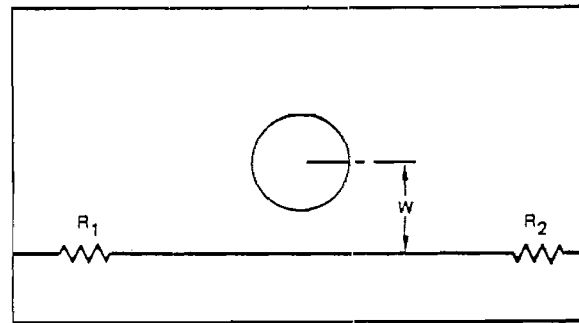
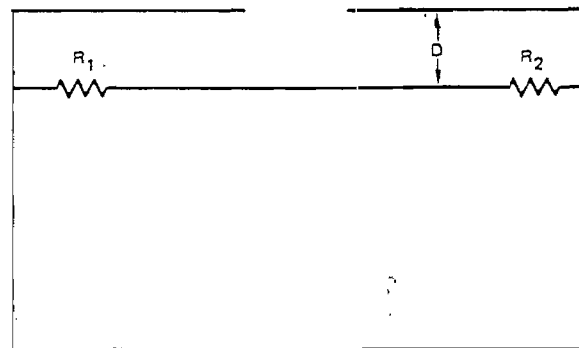

FIGURE A-6 ELECTRIC FIELD IN CENTER OF PARALLEL PLATE REGION



TOP VIEW



SIDE VIEW

FIGURE A-7 LOADED WIRE IN TEST VOLUME



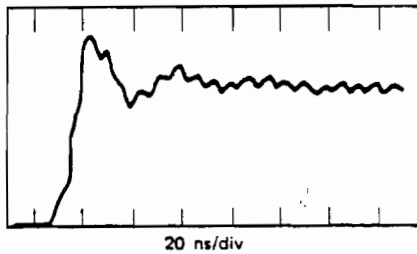

D (m)	I <sub>peak</sub> (ma)	
	W = 0	W = 0.23 m
0.007	400	3.3
0.050	160	—
0.100	92	16.8
0.500	42	19.6
0.500	12.4	7.6

(a)  $R_1 = R_2 = 0 \Omega$

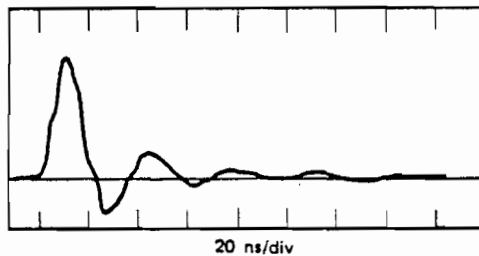

D (m)	I <sub>peak</sub> (ma)	
	W = 0	W = 0.23 m
0.007	48	0.3
0.050	22	—
0.100	13.2	2.8
0.200	—	3.8

(b)  $R_1 = R_2 = 240 \Omega$

FIGURE A-8 CURRENTS MEASURED ON WIRE IN TEST VOLUME  
(circular aperture with 0.10 m radius; waveshapes shown  
are typical)

### III. DISCUSSION OF THEORETICAL MODEL.

The transmission line coupling model of Figure A-2 was used by Davis<sup>4</sup> to investigate bounds on coupling to single-wire circuits behind an aperture. The source terms that drive the transmission line,  $V_{eq}$  and  $I_{eq}$ , depend on the moments of the equivalent electric and magnetic dipoles, which are derived from the external incident fields and from the size and shape of the aperture. Using a frequency domain analysis, Kajfez<sup>8</sup> has shown that the source terms are given by

$$V_{eq} = j\omega H_{sc} \alpha_m \left( \frac{\mu d}{\pi R_o} \right) \quad (1)$$

$$Z_o I_{eq} = j\omega E_{sc} \alpha_e \left( \frac{\epsilon n d}{\pi R_o} \right) \quad (2)$$

where  $H_{sc}, E_{sc}$  = Surface field components at the aperture with the aperture shorted.  
 $\alpha_m, \alpha_e$  = Magnetic and electric polarizabilities of the aperture.  
 $Z_o$  = Characteristic impedance of the equivalent transmission line.  
 $d, R_o$  = Dimensions defined in Figure A-2.

The polarizabilities for a circular aperture with radius  $R_{ap}$  are given by

$$\alpha_m = \frac{4}{3} R_{ap}^3 \quad (3)$$

$$\alpha_e = \frac{2}{3} R_{ap}^3 \quad (4)$$

The characteristic impedance of a wire with radius  $R_w$  over a ground plane is given by

$$Z_o = \frac{\eta}{2\pi} \ln\left(\frac{2d}{R_w}\right) \quad (5)$$

Davis uses the expressions above in the transmission line equation to arrive at equations for the currents and voltages at the load resistances. For the case where the load resistances are equal to  $Z_o$ , the expressions for the bounds simplify to

$$V_{\max} = \frac{|I_{eq} Z_o + V_{eq}|}{2} \quad (6)$$

$$I_{\max} = \frac{|V_{\max}|}{Z_o} \quad (7)$$

Later work by Davis and Sistanizadeh<sup>12,13</sup> applied these concepts to multiconductor transmission lines and derived bounds using matrix theory. These bounds were tested against Kajfez's analytical results for specific geometries,<sup>8</sup> and the agreement was reasonable.

The simple expressions above will be used with the parameters studied in our experiments and defined in Figure A-7. The external surface fields are those described in our earlier memoranda,<sup>6,7</sup> where the peak value of the time derivatives of the electric and magnetic fields were  $2.2 \text{ kV m}^{-1} \text{ ns}^{-1}$  and  $6 \text{ Am}^{-1} \text{ ns}^{-1}$ . The radius of the aperture is 0.1 m, and the dimensions  $d$  and  $R_o$  are related to  $D$  and  $W$  in Figures A-7 and A-8. The wire radius is 0.81 mm.

Eq. 1 and 2 for  $V_{eq}$  and  $I_{eq}$  contain the factor  $j\omega$  with the field quantities. These products ( $j\omega E$  and  $j\omega H$ ) translate to  $dE/dt$  and  $dH/dt$  in the time domain, and Eqs. 1 and 2 can be rewritten in the form

$$V_{eq} = \mu R \alpha_m \left| \frac{dH_{sc}}{dt} \right|_{\text{peak}} \quad (8)$$

$$Z_o I_{eq} = \epsilon \eta R \alpha_e \left| \frac{dE_{sc}}{dt} \right|_{\text{peak}} \quad (9)$$

where  $R = d/(\pi R_0^2)$ . For a circular aperture of radius 0.1 m, and for free-space values of  $\mu$  and  $\epsilon$ , these equations simplify to

$$V_{eq} = 1.67 \times 10^{-9} R H_{pk} \quad (10)$$

$$Z_o I_{eq} = 2.2 \times 10^{-12} R E_{pk} \quad (11)$$

These can be inserted into Eqs. 6 and 7, and  $I_{max}$  and  $V_{max}$  can be computed. Table A-1 compares the results of these calculations to the values measured in our laboratory.

Table A-1 shows that the computed currents are indeed larger than the measured currents, generally by less than a factor of 10. The first entry in the table ( $D = 0.007$ ,  $W = 0$ ) describes a configuration in which the internal wire is right in the aperture, a case for which the theory breaks down; i.e., the wire is well within an aperture radius of the aperture. However, the computed upper bounds are reasonable for the other cases listed for  $W = 0$ . As the wire is moved away from the aperture ( $W = 0.23$  m), the agreement improves somewhat.

Table A-1

MEASURED CURRENTS AND CALCULATED UPPER BOUNDS

(Aperture Radius = 0.1 m

$R_1 = R_2 = 240 \Omega$ )

D (m)	W (m)	$I_{mea}$ (ma)	$I_{cal}$ (ma)	Ratio $I_c/I_m$
0.007	0	48	1400	29.2
0.050	0	22	197	8.9
0.100	0	13.2	98.5	7.6
0.007	0.23	0.3	1.3	4.3
0.100	0.23	2.8	15.6	5.6
0.200	0.23	3.8	21.2	5.6

The most recent published papers on these bounds<sup>13,14</sup> contain comparisons with other analytical solutions of aperture coupling problems. Straightforward application of the more complicated bounding expressions results in upper bounds that are within a factor of 10 of the "exact" computed values. These bounds are worst-case calculations in the strictest sense, and Davis shows that a modest amount of insight can improve the upper-bound calculations (i.e., the upper bound can be made to approach the smallest upper bound).

#### IV. SUMMARY.

The aperture coupling measurements performed on this contract have provided a great deal of insight into the problem. Recent theoretical work on calculating upper bounds on internal transients has been shown to be of value, at least for the relatively simple receiving circuits tested in the laboratory. For parameters within the range of validity of the analytical model, the predicted upper bounds are less than a factor of 10 above the measured values. The problem not completely solved at this time, since the most important application of bounding, the multiconductor bundle, has yet to be examined in the laboratory. Alternative theoretical approaches to determining bounds are being investigated by others in the community, and these may improve the situation.

Measurement methods are being developed that will allow bounds to be determined for wires very close to the aperture. Baum<sup>11</sup> proposes measurements that are valid for wires located at least one aperture radius from the aperture. These measurements allow the direct determination of the  $V_{eq}$  and  $I_{eq}$  sources for the transmission line model.