

Interaction Notes

Note 330

June 1977

Electromagnetic Coupling to an Infinite Cable  
Placed Behind a Slot Perforated Screen\*

Korada R. Umashankar and James R. Wait

Cooperative Institute for Research in Environmental Sciences  
University of Colorado/NOAA  
Boulder, Colorado 80309

Abstract

We present an analysis of the electromagnetic coupling from an external illuminating field to an infinitely long thin cable placed behind the conducting screen that is perforated by a narrow slot. By using a Fourier transform representation for the unknown electric current on the cable, we obtain an integro-differential equation for the distribution of the electric field in the slot that accounts completely for the coupling. The transfer admittance function so obtained, is in a form very convenient to estimate the electric current on the infinite cable. Results of the slot electric field distribution and the current induced on the infinite cable are given for a few typical cases. Not surprisingly, the axial distribution of induced voltage on the slot is markedly affected by the presence of the cable.

1. INTRODUCTION

In electromagnetic interference studies, one often needs to assess the response of protected objects behind perforated metallic screens. Also, in related scattering problems, the distribution of the electric field in the aperture determines the radiation mechanism which has a direct bearing on the electromagnetic coupling to nearby objects. As shown by Butler and Umashankar [1], the fields in the aperture are affected by the presence of

---

\* Research supported in part by United States Air Force under AFWL Project Order No. 77-109 with the Institute of Telecommunication Sciences, U.S. Dept. of Commerce, Boulder, CO 80302 (Principal Investigator, Dr. D.A. Hill)



nearby scatterers. They considered the boundary value problem of a finite thin wire behind a slotted conducting screen and derived a coupled set of integro-differential equations where the distribution of the electric field in the narrow slot and the induced current on the finite thin wire were unknown. Such formulations [1,2,3] are only tractable at relatively low frequencies because of the excessive computing needed. Also, this method would not be viable when dealing with very long cables or bundles of cables located behind such aperture perforated screens. However, as we shall show, one may formulate the basic integro-differential equations for such situations in a form more convenient for calculation.

In this paper, an integro-differential equation is given for the case of an infinitely long cable placed behind a narrow finite rectangular slot in a conducting screen and an efficient approach to calculate the current response of the cable with complete account of slot coupling is indicated. The method is similar to that used by Hill and Wait [4] who were concerned with the response of coaxial cables to dipolar fields.

## II. FORMULATION

The geometry of the problem discussed is shown in Fig. 1. The infinitely long cable is oriented along the z-axis and is placed at a distance  $x=h$  and  $y=d$  in the upper half space  $y>0$ . The xz- plane of the coordinate system contains the perfectly conducting ground plane which has an x-directed narrow slot of length  $\ell$  and width  $w$  whose center coincides with the origin. The illuminating field  $(\vec{E}^i, \vec{H}^i)$  is incident from the lower half space  $y<0$ , and the narrow slot, in turn, radiates and has a direct coupling to the infinite cable.

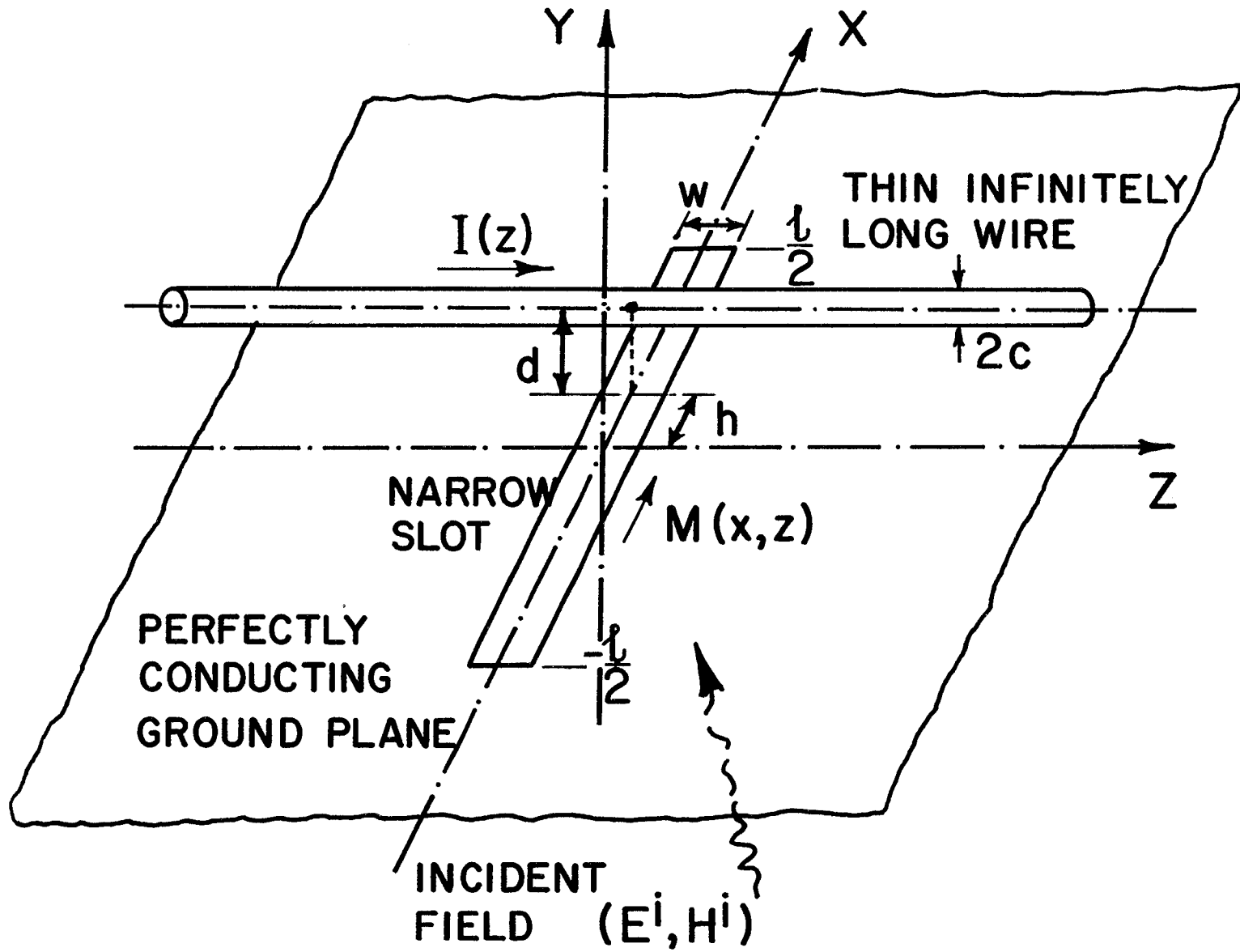

Figure 1. Thin infinitely long cable behind a narrow rectangular slot perforated conducting screen.

In the following, an integro-differential equation is formulated in terms of an induced current  $\hat{u}_z I_z(z)$  on the thin infinite cable, and a tangential slot electric field  $\bar{E}_t^A$  or an equivalent magnetic current distribution  $\hat{u}_x M_x(x', z') = \bar{E}_t^A(x', z') \times \hat{u}_y$  where  $\hat{u}_x$ ,  $\hat{u}_y$  and  $\hat{u}_z$  are the direction vectors of the coordinate system. The fields in the two half spaces can be calculated once the distributions  $I_z$  and  $M_x$  are known. It is assumed that  $I_z$  has no significant rotational variation and that  $M_x(x', z')$  can be written as

$$M_x(x', z') = m(x') \zeta(z') \quad (1a)$$

for the narrow slot distribution. Here  $m(x)$  is the yet to be determined, variation of the longitudinal field in the slot and  $\zeta(z')$  accounts for the transverse variation in the slot field which is assumed to have the static distribution [1]:

$$\zeta(z') = \frac{1}{\pi} [(w/2)^2 - (z')^2]^{-1/2} \quad (1b)$$

(i) Determination of Electric Current Distribution  $I_z(z)$

In Fig. 2c is shown an equivalent of the original problem valid for  $y > 0$ . Here the primary magnetic Hertz potential  $\pi_x^*$  due to magnetic current distribution  $-2M_x$  is given by [5]:

$$\pi_x^*(x, y, z) = \frac{1}{j2\pi\omega\mu} \int_{-\ell/2}^{+\ell/2} m(x') \frac{e^{-\gamma R}}{R} dx', \quad \text{for } y > 0 \quad (2a)$$

where the propagation constant, applicable to both sides of the sheet, is

$$\gamma = [j\omega\mu(\sigma + j\omega\epsilon)]^{1/2} \quad (2b)$$

and

$$R = [(x-x')^2 + y^2 + z^2]^{1/2} \quad (2c)$$

In writing the above and in what follows, we have adopted an  $\exp(j\omega t)$  time factor.

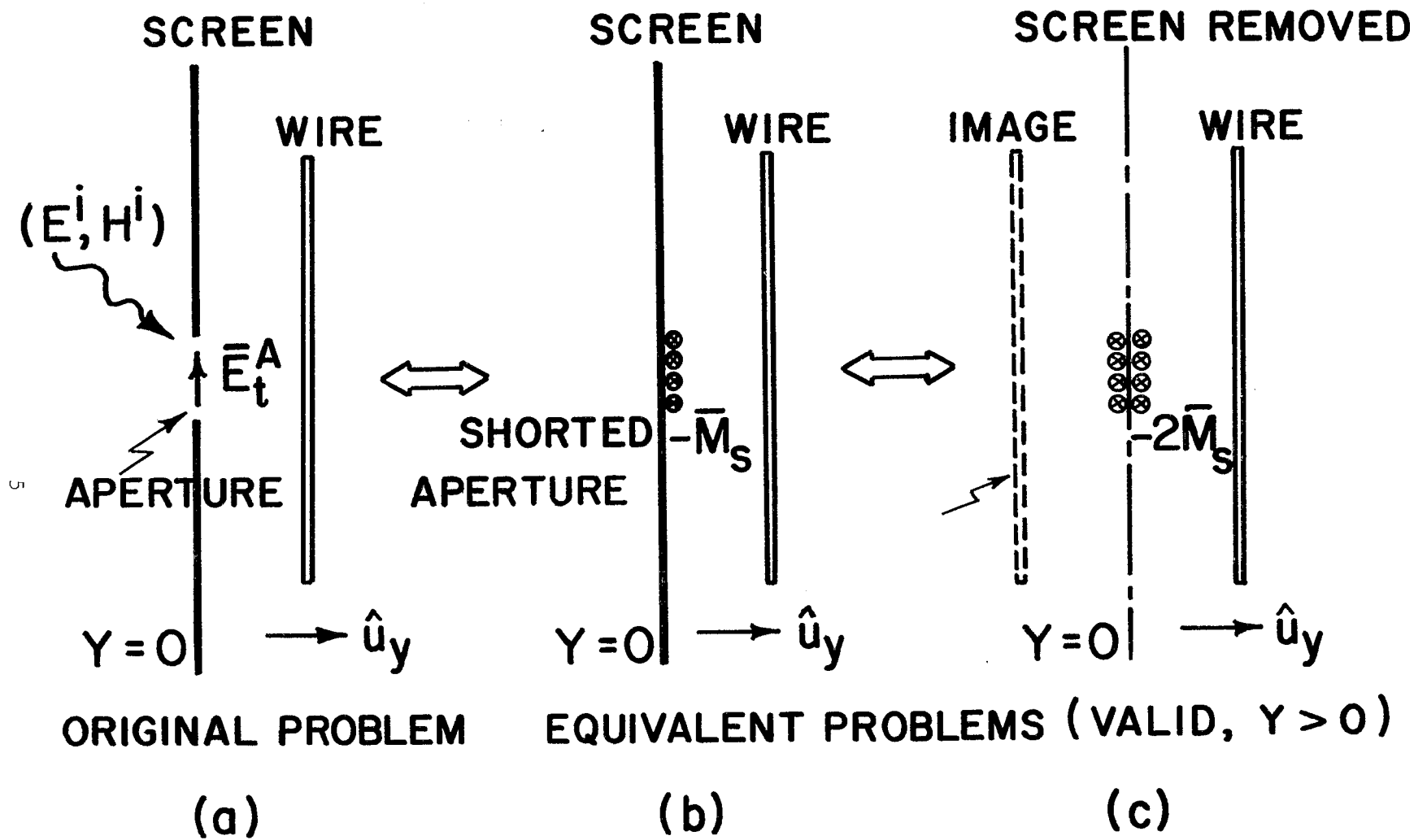

Figure 2. Upper half-space equivalent problem, valid for  $y > 0$ .

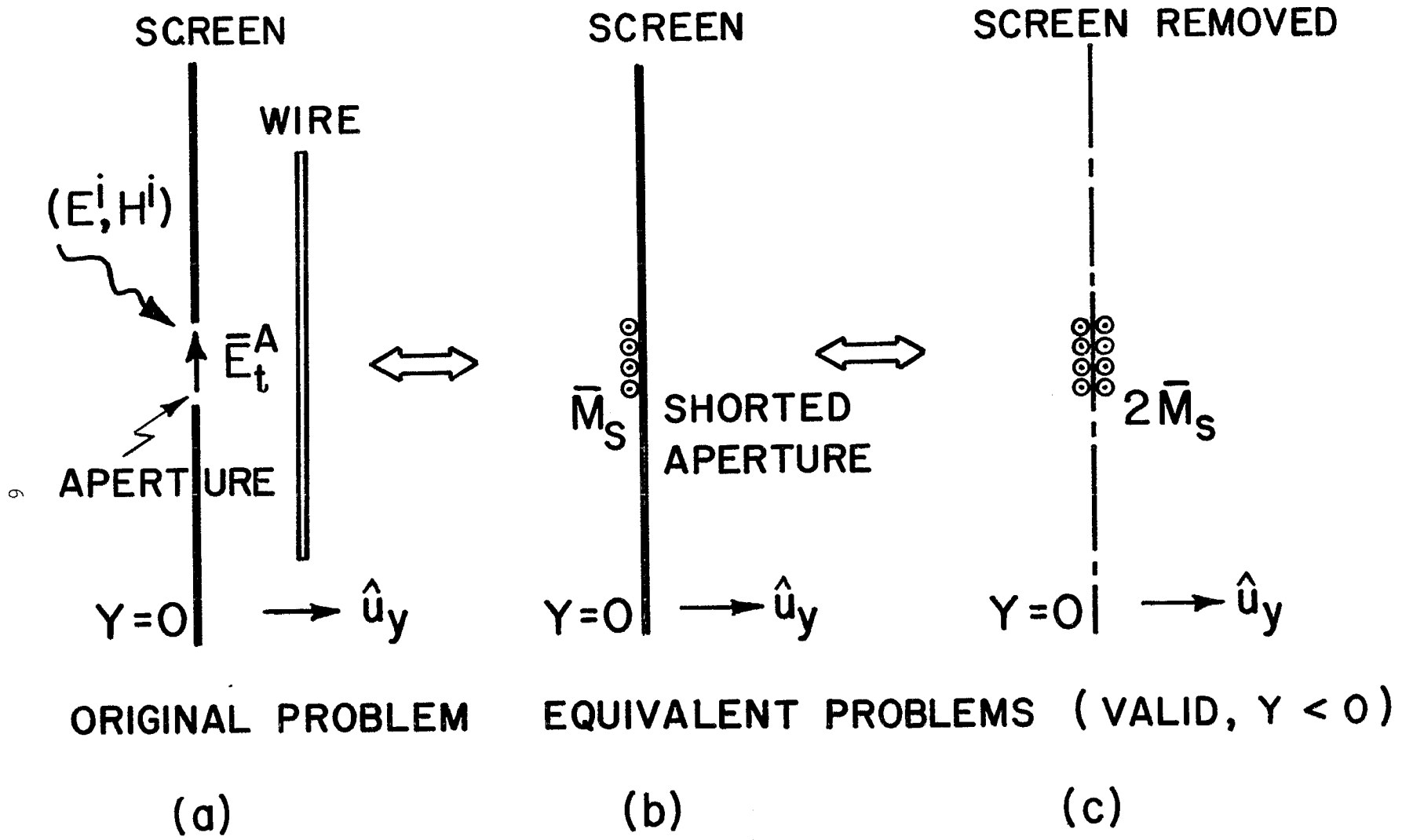

Figure 3. Lower half-space equivalent problem, valid for  $y < 0$ .

We now utilize the identity [6],

$$\frac{e^{-\gamma R}}{R} = \frac{2}{\pi} \int_0^{\infty} K_0(ur) \cos \lambda z \, d\lambda \quad (3a)$$

where  $K_0$  is the modified Bessel function of the second kind of zero order where

$$u = (\lambda^2 + \gamma^2)^{\frac{1}{2}} \quad (3b)$$

$$\text{and} \quad r = [(x-x')^2 + y^2]^{\frac{1}{2}} \quad (3c)$$

Then the expression (2a) reduces to the form

$$\pi_x^*(x, y, z) = \frac{1}{j\omega\mu\pi^2} \int_{-\ell/2}^{+\ell/2} m(x') \left[ \int_0^{\infty} K_0(ur) \cos \lambda z \, d\lambda \right] dx' \quad (4)$$

Now, because of symmetry, the z- component of the primary electric field of the magnetic current distribution is given by [5]:

$$E_z^P(x, y, z) = -j\omega\mu \frac{\partial \pi_x^*}{\partial y} = \left( \frac{2}{\pi} \right)^{\frac{1}{2}} \int_0^{\infty} \hat{E}_z^P(x, y, \lambda) \cos \lambda z \, d\lambda \quad (5)$$

where  $\hat{E}_z^P$  by definition is the Fourier cosine transform of  $E_z^P$ . Then it follows that

$$\left( \frac{2}{\pi} \right)^{\frac{1}{2}} \hat{E}_z^P(\lambda) = \frac{1}{\pi^2} \int_{-\ell/2}^{+\ell/2} m(x') \frac{uy}{r} K_1(ur) dx' \quad (6)$$

where  $K_1$  is the modified Bessel function of the second kind of first order.

In a similar fashion, we may deduce the z- component of the secondary electric Hertz potential due to the infinitely long cable and its image.

This must have the form

$$\pi_z^S(x, y, z) = \int_0^{\infty} F(\lambda) [K_0(ur_1) - K_0(ur_2)] \cos \lambda z \, d\lambda, \quad y > 0, \quad (7a)$$

$$r_1 = [(x-h)^2 + (y-d)^2]^{\frac{1}{2}} \quad (7b)$$

and

$$r_2 = [(x-h)^2 + (y+d)^2]^{\frac{1}{2}} \quad (7c)$$

In fact, the secondary electric Hertz potential has the right boundary condition, i.e.

$$\pi_z^S(x, y, z) \Big|_{y=0} = 0.$$

Actually, the term  $F(\lambda)$  is directly proportional to the transformed current  $\hat{I}_z(\lambda)$  of the electric current distribution  $I_z(z)$  on the infinitely long cable. This is seen from (7a) where we may write

$$I_z(z) = \left(\frac{2}{\pi}\right)^{\frac{1}{2}} \int_0^{\infty} \hat{I}_z(\lambda) \cos \lambda z \, d\lambda = -(\sigma + j\omega\epsilon) \int_0^{2\pi} \rho' \frac{\partial \pi_z^S}{\partial \rho'} \, d\phi' \Big|_{\rho'=c} \quad (8)$$

where  $\rho'$  and  $\phi'$  are the local cylindrical coordinates about the cable axis and  $c$  is the radius of the cable wire. Then it follows from (7a) that

$$\left(\frac{2}{\pi}\right)^{\frac{1}{2}} \hat{I}_z(\lambda) = 2\pi c(\sigma + j\omega\epsilon)u[K_1(uc) - K_1(2ud)]F(\lambda) \quad (9)$$

Furthermore, the  $z$ - component of the secondary electric field is obtained from

$$E_z^S(x, y, z) = \left(\frac{d^2}{dz^2} - \gamma^2\right) \pi_z^S(x, y, z) \quad (10a)$$

and the corresponding transform is then

$$\left(\frac{2}{\pi}\right)^{\frac{1}{2}} \hat{E}_z^S(x, y, \lambda) = -u^2[K_0(ur_1) - K_0(ur_2)]F(\lambda) \quad (10b)$$



Now we are in a position to enforce the cable wire boundary condition [4]:

$$[\hat{E}_z^p(\lambda) + \hat{E}_z^s(\lambda)]_{\rho'=c} = Z(\lambda) \hat{I}_z(\lambda) \Big|_{\rho'=c} \quad (11)$$

where  $Z(\lambda)$  is the impedance of the cable per unit length. For example, for the bare cable conductor [7], with  $|\gamma_w|^2 \gg \lambda^2$ ,

$$Z(\lambda) \cong \frac{\gamma_w I_0(\gamma_w c)}{2\pi\sigma_w c I_1(\gamma_w c)} \quad (12a)$$

in which

$$\gamma_w = [j\sigma_w \mu\omega]^{1/2} \quad (12b)$$

where  $\sigma_w$  being the conductivity of the cable material, and  $I_0, I_1$  are the modified Bessel functions of first kind, zero and first orders, respectively. More complicated  $\lambda$ -dependent forms arise in other cable types.

By substituting expressions (6), (9), and (10b) into the cable boundary condition (11), the term  $F(\lambda)$  proportional to the transform of the electric current distribution on the infinitely long cable reduces to,

$$F(\lambda) = \frac{\frac{1}{\pi^2} \int_{-\ell/2}^{+\ell/2} m(x') \frac{d}{r_c} K_1(ur_c) dx'}{u[K_0(uc) - K_0(2ud)] + 2\pi c(\sigma + j\omega\epsilon)[K_1(uc) - K_1(2ud)]Z(\lambda)} \quad (13a)$$

where

$$r_c = [(h-x')^2 + d^2]^{1/2} \quad (13b)$$

Hence the distribution of the actual electric current on the infinitely long cable can be obtained by the expressions (8b), (9), and (13a). Thus

$$I_z(z) = \int_{-\ell/2}^{+\ell/2} m(x') T(z, x') dx' \quad (14a)$$

where

$$T(z, x') = \int_0^{\infty} \hat{T}(\lambda, x') \cos \lambda z \, d\lambda \quad (14b)$$

and

$$\hat{T}(\lambda, x') = \frac{2c}{\pi} \frac{(\sigma + j\omega\epsilon) u \left( \frac{d}{r_c} \right) K_1(ur_c) [K_1(uc) - K_1(2ud)]}{u [K_0(uc) - K_0(2ud)] + 2\pi c (\sigma + j\omega\epsilon) [K_1(uc) - K_1(2ud)] Z(\lambda)} \quad (14c)$$

For the special case of a perfect cable conductor  $Z(\lambda) = 0$ , placed at least few radii above the slot, the expression (14c) reduces to a simpler form

$$\hat{T}(\lambda, x') = \frac{2c}{\pi} (\sigma + j\omega\epsilon) \left( \frac{d}{r_c} \right) \frac{K_1(ur_c) K_1(uc)}{K_0(uc)} \quad (14d)$$

The expression (14a) is an expression for the current  $I_z(z)$  in terms of the slot distribution  $m(x')$  and would be an explicit if the slot were electrically small.

### (ii) Determination of the Magnetic Current Distribution $m(x')$

We now derive an integro-differential equation that will be used to determine the unknown function  $m(x')$ . We first write down the corresponding expressions for the total magnetic field  $\bar{H}^+$  and  $\bar{H}^-$  in the half space regions  $y > 0$  and  $y < 0$  respectively. Then we enforce the remaining boundary condition [1,2] that the components of the total magnetic field transverse to  $y$  should be continuous in the slot i.e.,

$$\lim_{y \rightarrow 0^+} \bar{H}^+ \times \hat{u}_y = \lim_{y \rightarrow 0^-} \bar{H}^- \times \hat{u}_y \quad (15)$$

Referring to Fig. 2c, the total magnetic field valid for the region  $y > 0$ , is

$$\bar{H}^+ = -[\nabla(\nabla \cdot \hat{u}_x \pi_x^*) - \gamma^2 \hat{u}_x \pi_x^*] + (\sigma + j\omega\epsilon) \nabla \times \hat{u}_z \pi_z^s \quad (16a)$$

Similarly with reference to Fig. 2c, the total magnetic field valid for the region  $y < 0$ , is

$$\bar{H}^- = [\nabla(\nabla \cdot \hat{u}_x \pi_x^*) - \gamma^2 \hat{u}_x \pi_x^*] + \bar{H}^{sc} \quad (16b)$$

where  $\bar{H}^{sc}$  being the short circuit magnetic field in the region  $y < 0$ .

On substituting (16a) and (16b) into the slot boundary condition (15), we have an integro-differential equation

$$\left[ \frac{\partial^2}{\partial x^2} - \gamma^2 \right] \pi_x^* - \frac{(\sigma + j\omega\epsilon)}{2} \frac{\partial}{\partial y} \pi_z^s = -H_x^i \quad (17)$$

where  $\pi_x^*$  and  $\pi_z^s$  are given by the expressions (2a) and (7a) respectively, and  $H_x^i$  is the x- component of the incident magnetic field excitation on the slot. A plane wave with its direction of propagation making an angle  $\theta$  with the slot axis is now assumed to excite the slot. Then the  $H_x^i$  component of the magnetic field in the above expression (17) is given by

$$H_x^i(x) = H_{x0} \sin\theta e^{-\gamma x \cos\theta} \quad (18)$$

where  $H_{x0}$  is a specified amplitude factor.

On substituting the Hertz potential expressions for  $\pi_x^*$  and  $\pi_z^s$  as given by (2a) and (7a), the integro-differential equation (17) takes the form

$$\begin{aligned} & \left[ \frac{\partial^2}{\partial x^2} - \gamma^2 \right] \int_{-l/2}^{+l/2} m(x') K(x, x') dx' \\ & + \int_{-l/2}^{+l/2} m(x') G(x, x') dx' = -j2\pi\omega\mu H_x^i(x), \text{ on the slot } x \in \left(-\frac{l}{2}, \frac{l}{2}\right) \end{aligned} \quad (19a)$$

where

$$K(x, x') = \frac{e^{-\gamma R_s}}{R_s} \quad (19b)$$

and

$$R_s = \left[ (x-x')^2 + \left(\frac{w}{4}\right)^2 \right]^{1/2} \quad (19c)$$

$$G(x, x') = - \int_0^{\infty} \frac{2}{\pi} \gamma^2 u \left(\frac{d}{r_c}\right) \left(\frac{d}{r_s}\right) \frac{K_1(ur_c)K_1(ur_s)d\lambda}{u[K_0(uc) - K_0(2ud)] + 2\pi c(\sigma + j\omega\epsilon)[K_1(uc) - K_1(2ud)]Z(\lambda)} \quad (19d)$$

where

$$r_s = \left[ (x-h)^2 + d^2 \right]^{1/2} \quad (19e)$$

For the special case of a perfect electric conductor  $Z(\lambda) = 0$ , and assuming the cable is placed at least a few radii above the slot,

$$G(x, x') = - \int_0^{\infty} \frac{2}{\pi} \gamma^2 \left(\frac{d}{r_c}\right) \left(\frac{d}{r_s}\right) \frac{K_1(ur_c)K_1(ur_s)}{K_0(uc)} d\lambda \quad (19f)$$

The final form of the integro-differential equation (19a) for the unknown magnetic current distribution  $m(x')$ , is in a convenient form for numerical analysis. The first term can be recognized as an integral expression for an isolated narrow slot, while the presence of the second term, which has inherently built in Fourier transform of the current distribution on the infinite cable, accounts for the transfer coupling between slot and the infinite cable. The expression (19a) may now be converted into a matrix equation [8] by expanding the  $m(x')$  distribution in terms of a piecewise pulse function

$$m(x') = \sum_{n=1}^N M_{n^n} p_n(x') \quad (20)$$

and testing it by piecewise linear functions. This numerically oriented matrix method enables one to determine the magnetic current distribution  $m(x')$ . After substituting back the expression (20) into (14a), the electric

current response  $I_z(z)$  on the infinite cable can be evaluated.

Finally, we note that in the expression (14a),  $T(z,x')$  is a transfer admittance function that can be quite useful for circuit modelling of the coupled region between slot and the infinite cable.

### III. NUMERICAL EXAMPLES

The integro-differential equation (19a) is now solved numerically based on matrix methods as outlined in [8] for a few cases of interest. In Fig. 4 we show the resulting distribution of the slot axial magnetic current  $m(x)$  along the slot axis for a typical case of 0.5 meter narrow resonant slot with total length to width ratio of 10. Here the illuminating plane wave is assumed to be incident normally on the slot from the region  $y < 0$ . The infinitely long cable is located at a distance  $h=0$  and 0.5 meter, and  $d=0.25$  meter from the center of the slot. As indicated in Fig. 4, the results for isolated slots are completely altered both in magnitude and in the distribution according to the location of the infinite cable.

The slot magnetic current distribution as obtained in Fig. 4 is further used in the expression (14a) to estimate the distribution of the induced electric current on the infinite cable. Fig. 5 shows the real and imaginary parts of the total axial current  $I(z)$  as a function of  $|z|$ . Away from the axis  $z=0$ , the current on the infinite cable does exhibit a small damping behavior and oscillates approximately at the wave length of the incident plane wave field. Here we have assumed  $\mu = \mu_0$ ,  $\epsilon = \epsilon_0$  and  $\sigma = 0$ .

### IV. CONCLUDING REMARKS

For the problem of an infinite cable placed behind a narrow slot perforated conducting screen, we have obtained an integro-differential equation

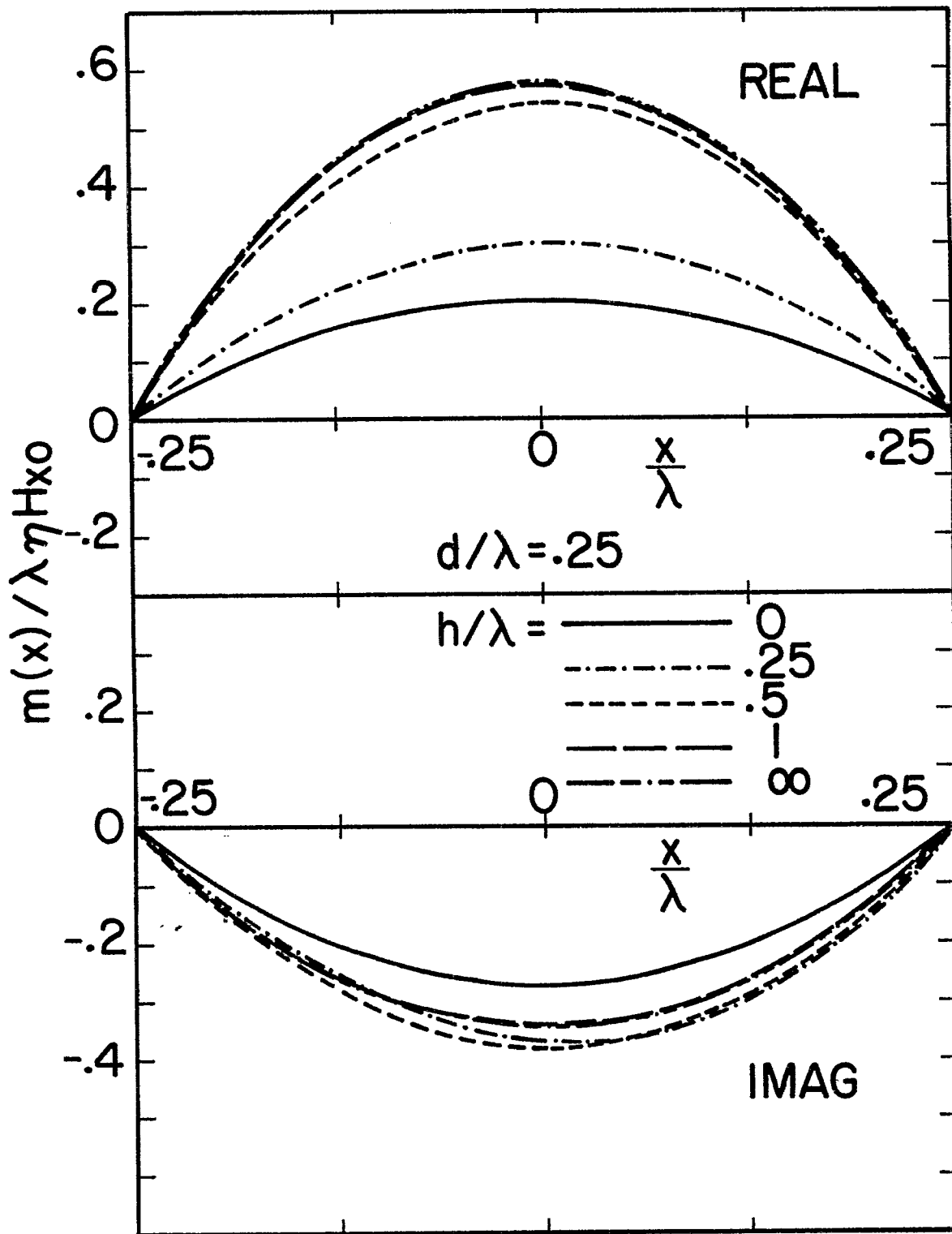

Figure 4. Distribution of the axial slot magnetic current along the center line,  $z=0$ , for freq. = 300 MHz,  $\ell = 0.5$ ,  $Z(\lambda) = 0$ ,  $w = 0.05$ , and  $c = 0.005$  meter.

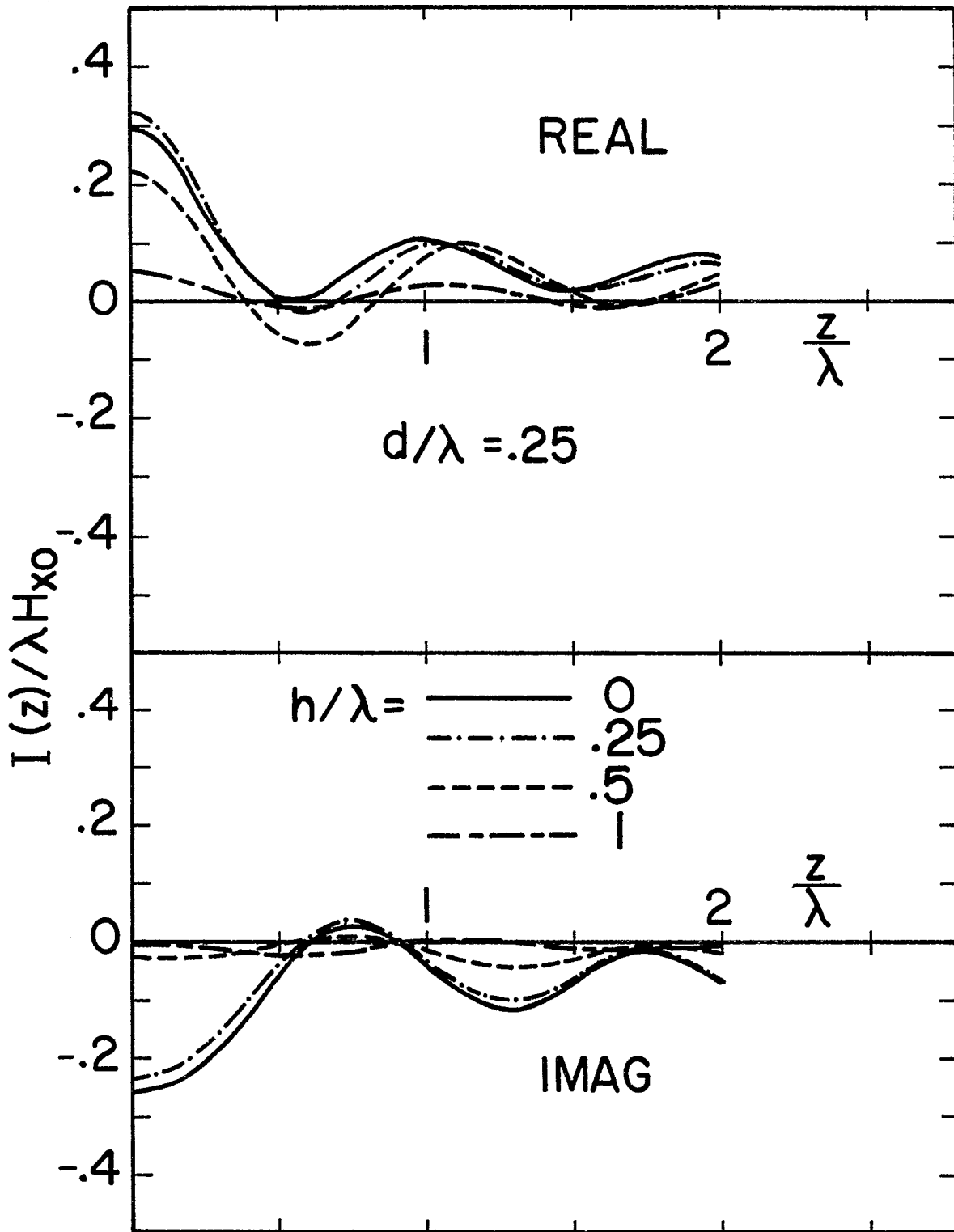

Figure 5. Distribution of the electric current on the infinitely long cable for freq. = 300 MHz,  $\rho = 0.5$ ,  $Z(\lambda) = 0$ ,  $w = 0.05$ , and  $c = 0.005$  meter.

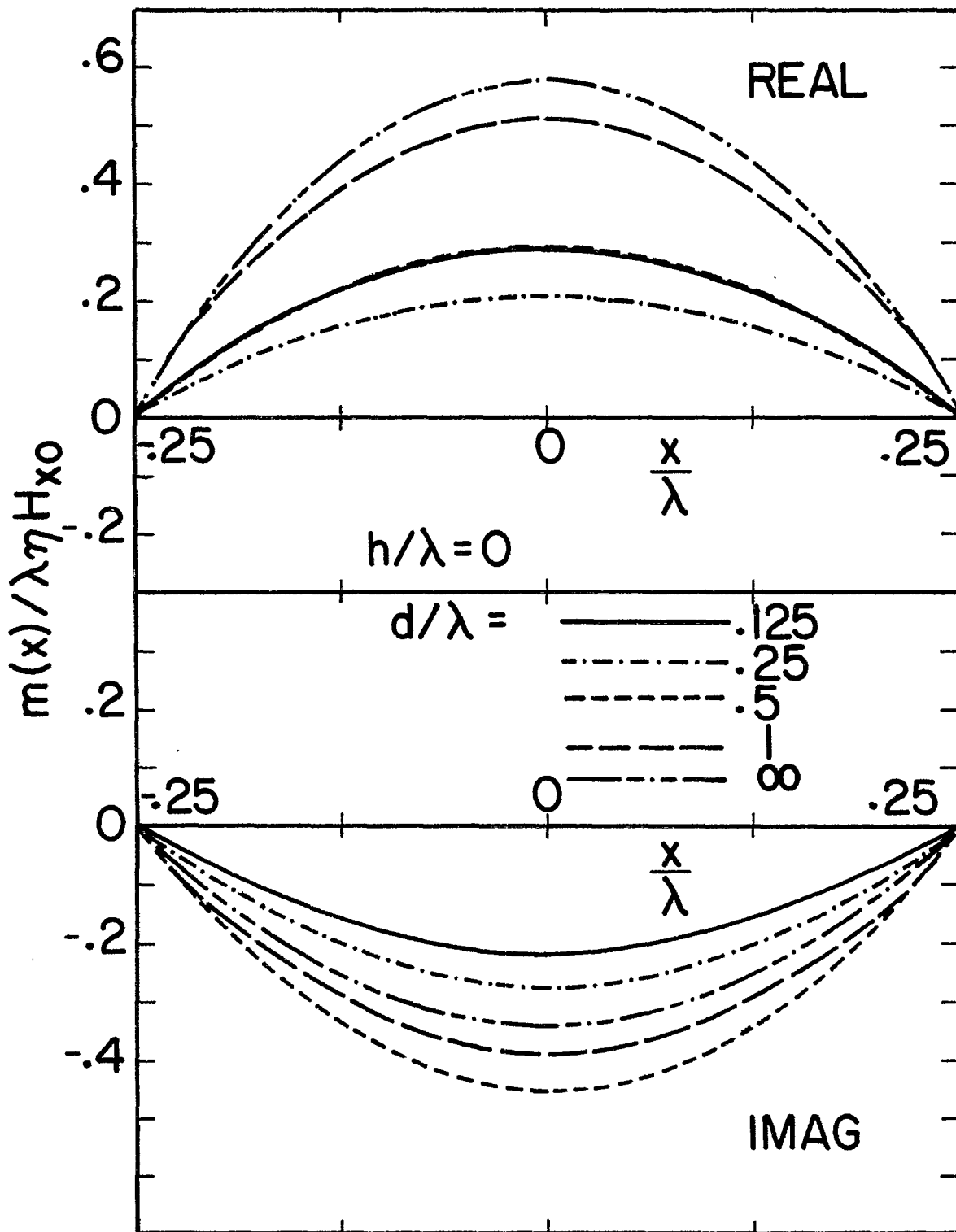

Figure 6. Distribution of the axial slot magnetic current along the center line,  $z=0$ , for freq. = 300 MHz,  $\epsilon=0,5$ ,  $Z(\lambda) = 0$ ,  $w = 0.05$ , and  $c = 0.005$  meter.



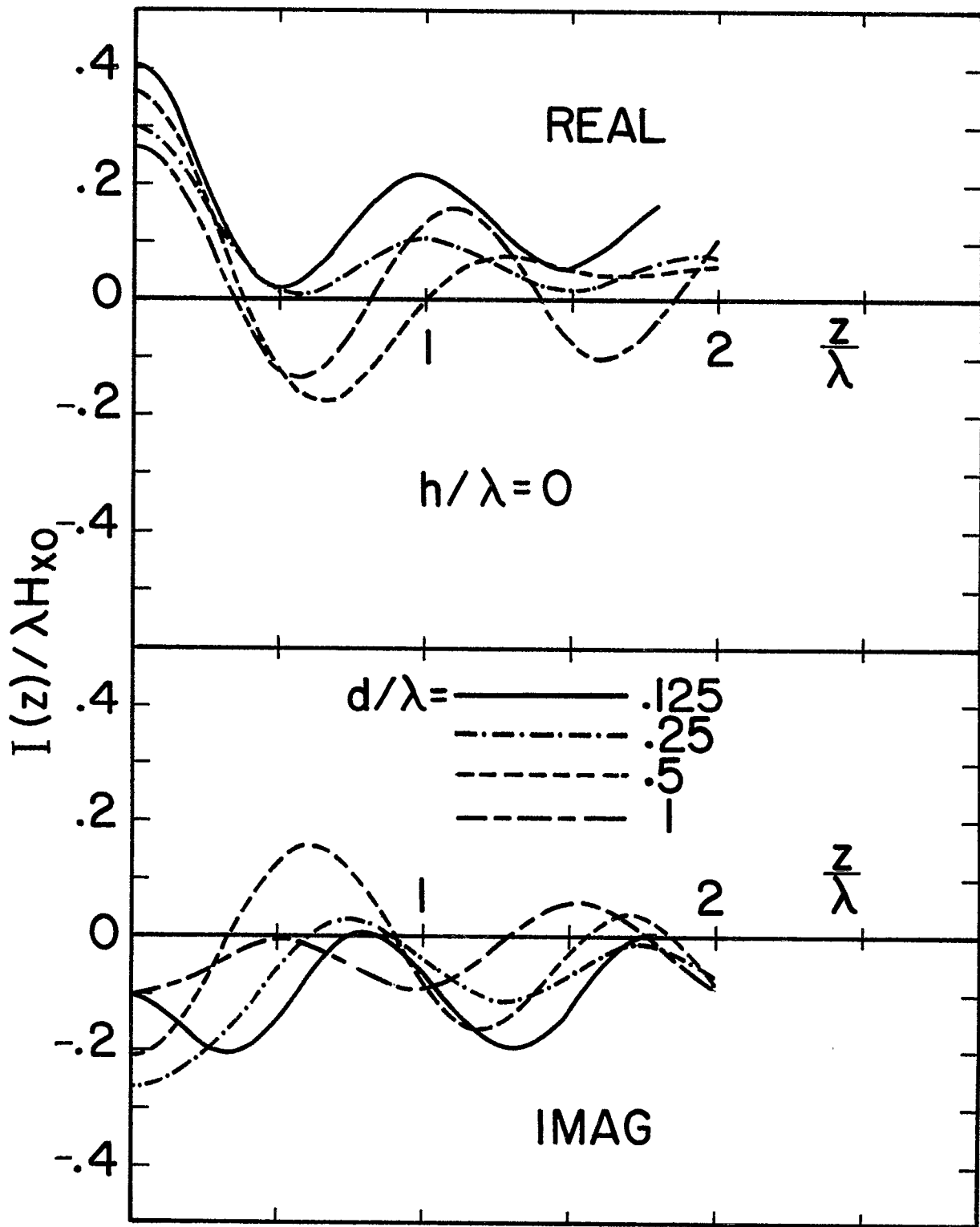

Figure 7. Distribution of the electric current on the infinitely long cable for freq. = 300 MHz,  $\epsilon = 0.5$ ,  $Z(\lambda) = 0$ ,  $w = 0.05$ , and  $c = 0.005$  meter.

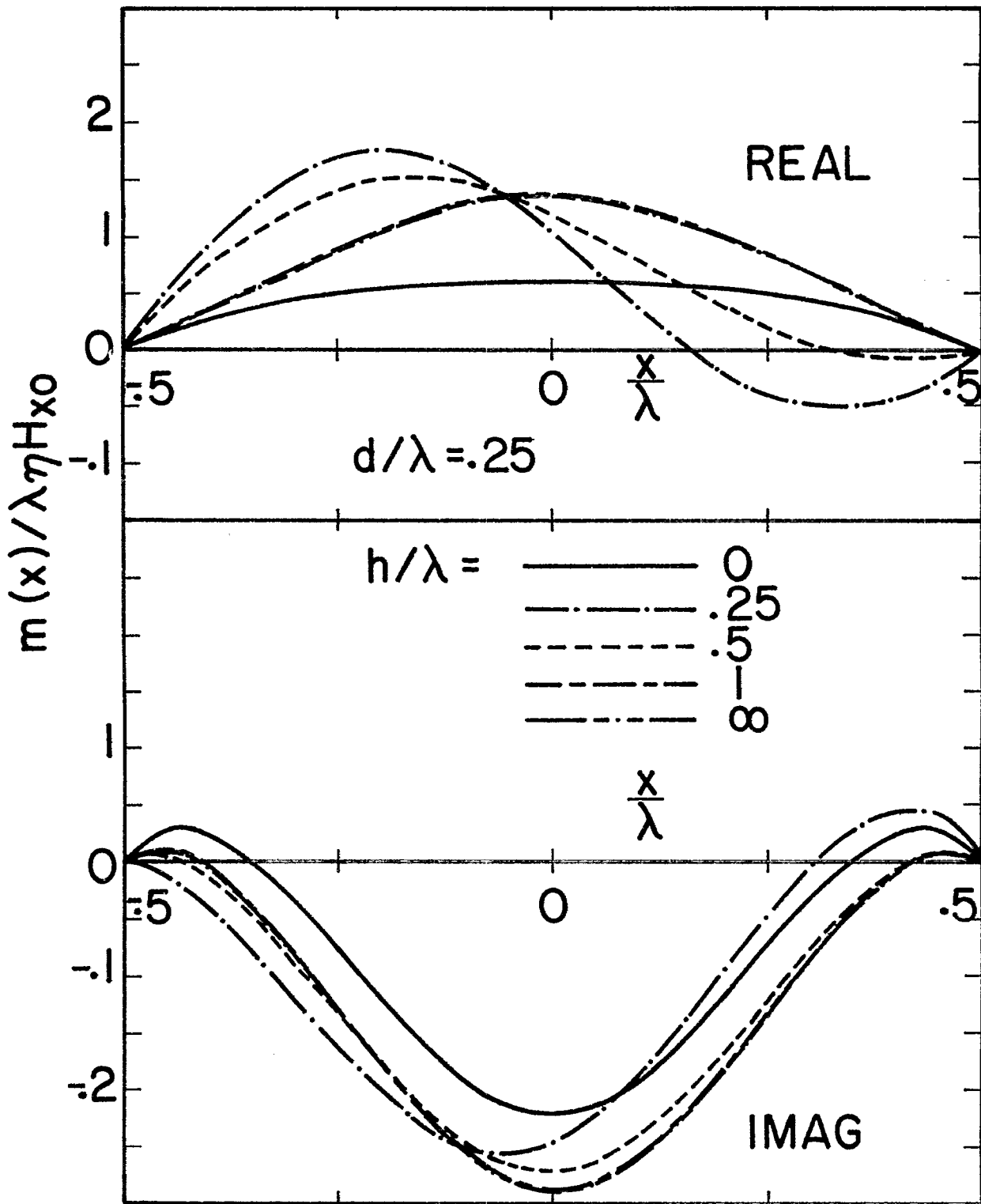

Figure 8. Distribution of the axial slot magnetic current along the center line,  $z=0$ , for freq. = 300 MHz,  $\epsilon = 1.0$ ,  $Z(\lambda) = 0$ ,  $w = 0.05$ , and  $c = 0.005$  meter.

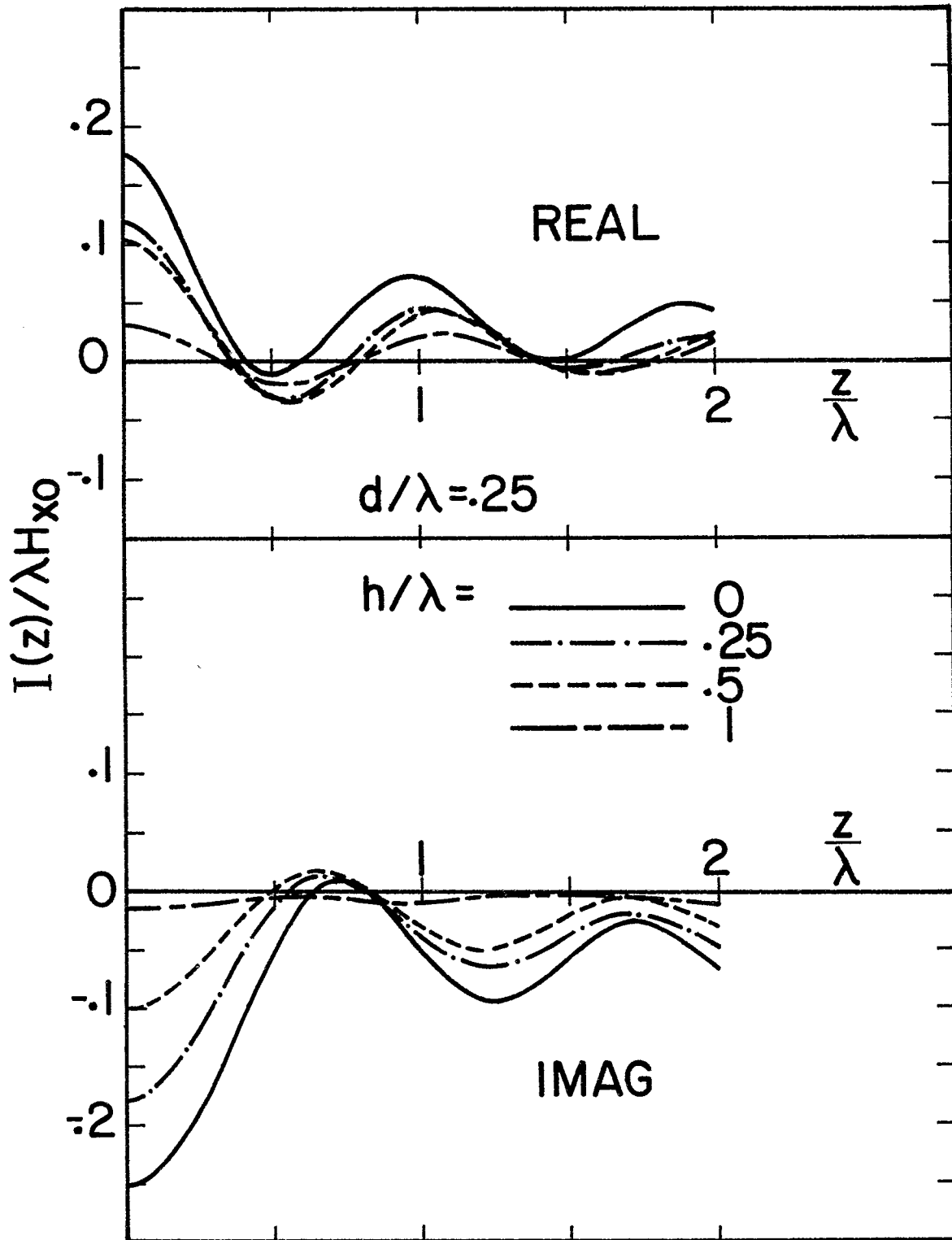

Figure 9. Distribution of the electric current on the infinitely long cable for freq. = 300 MHz,  $\epsilon = 1.0$ ,  $Z(\lambda) = 0$ ,  $w = 0.05$ , and  $c = 0.005$  meter.

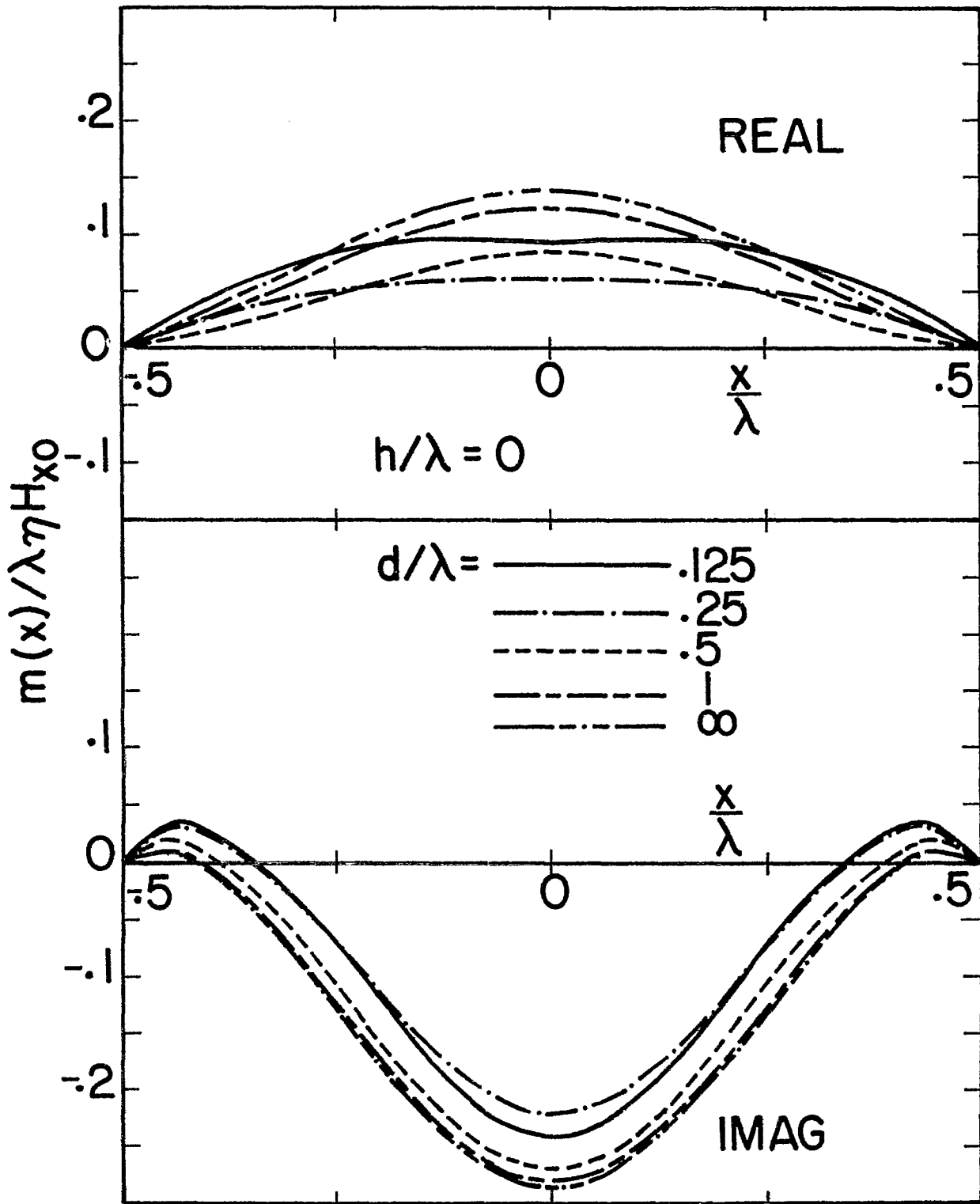

Figure 10. Distribution of the axial slot magnetic current along the center line,  $z=0$ , for freq. = 300 MHz,  $\epsilon = 1.0$ ,  $Z(\lambda) = 0$ ,  $w = 0.05$ , and  $c = 0.005$  meter.

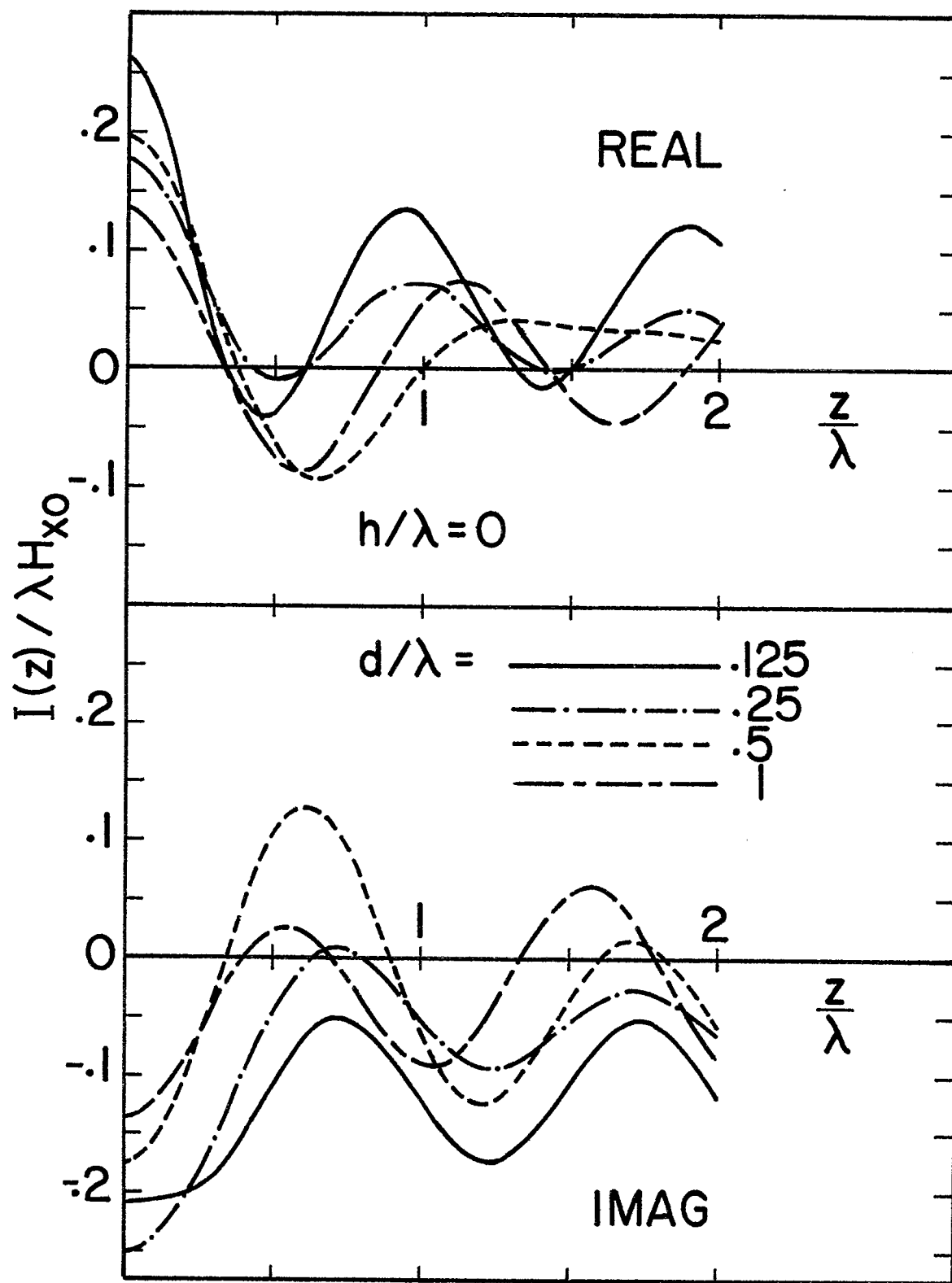

Figure 11. Distribution of the axial slot magnetic current along the center line,  $z=0$ , for freq. = 300 MHz,  $\ell = 1.0$ ,  $Z(\lambda) = 0$ ,  $w = 0.05$ , and  $c = 0.005$  meter.

in an uncoupled, but in a modified form to determine the unknown electric field in the slot. Also, an expression has been given for the current induced on the infinite cable in terms of the slot magnetic current distribution and the transfer admittance function. In this approach, the complete coupling between the slot and infinite cable was taken into account. Only the usual thin wire and narrow slot approximations were introduced.

One could extend the formulation to a more general rectangular aperture, but then we would encounter a set of coupled integro-differential equations with semi-infinite integral-kernels, for the field distribution in the aperture. This would be a worthwhile task for the future.

## REFERENCES

- [1] C.M. Butler and K.R. Umashankar, "Electromagnetic excitation of a wire through an aperture perforated conducting screen", *IEEE Trans. on Antennas and Propagation*, Vol. 24, No. 4, pp. 456-462, July 1976, and also *EMP Interaction Note 251*, Air Force Weapons Lab., Kirtland AFB, New Mexico, June 1975.
- [2] C.M. Butler and K.R. Umashankar, "Electromagnetic penetration through an aperture in an infinite planar screen separating two half spaces of different electromagnetic properties", *Radio Science*, Vol. 11, No. 7, pp. 611-619, July 1976.
- [3] K.R. Umashankar and C.M. Bulter, "A numerical solution procedure for small aperture integral equations", *EMP Interaction Note 212*, Air Force Weapons Lab., Kirtland AFB, New Mexico, July 1974.
- [4] D.A. Hill and J.R. Wait, "Coupling between a dipole antenna and an infinite cable over an ideal ground plane", *Radio Science*, Vol. 12, No. 2, 231-238, March/April 1977.
- [5] J.R. Wait, *Electromagnetic Waves in Stratified Media*, 2nd Edition, Pergamon Press: New York, 1970.
- [6] M. Abramowitz and I. Stegun, *Handbook of Mathematical Functions*. New York: Dover, 1965.
- [7] J.R. Wait, *Electromagnetic Radiation From Cylindrical Structures*. New York: Pergamon Press, 1959.
- [8] C.M. Butler, K.R. Umashankar and C.E. Smith, "Theoretical analysis of the wire biconical antenna", *Technical report*, U.S. Army Stratcom, Ft. Huachuca, Arizona, January 1975.