

UNCLASSIFIED

SECURITY CLASSIFICATION OF THIS PAGE (When Data Entered)

REPORT DOCUMENTATION PAGE		READ INSTRUCTIONS BEFORE COMPLETING FORM
1. REPORT NUMBER HDL-TR-1716	2. GOVT ACCESSION NO.	3. RECIPIENT'S CATALOG NUMBER
4. TITLE (and Subtitle) Electromagnetic Response of a Sphere Over a Ground Plane in the Presence of Source and Conduction Currents in the Air		5. TYPE OF REPORT & PERIOD COVERED Technical Report
		6. PERFORMING ORG. REPORT NUMBER
7. AUTHOR(s) John N. Bombardt, Jr.		8. CONTRACT OR GRANT NUMBER(s) AMC: 1W162118AH-75 DNA: R99QAXEB088/51
9. PERFORMING ORGANIZATION NAME AND ADDRESS Harry Diamond Laboratories 2800 Powder Mill Road Adelphi, MD 20783		10. PROGRAM ELEMENT, PROJECT, TASK AREA & WORK UNIT NUMBERS
11. CONTROLLING OFFICE NAME AND ADDRESS Director Defense Nuclear Agency Washington, DC 20305		12. REPORT DATE October 1975
		13. NUMBER OF PAGES 51
14. MONITORING AGENCY NAME & ADDRESS (if different from Controlling Office) Commander Army Materiel Command 5001 Eisenhower Avenue Alexandria, VA 22333		15. SECURITY CLASS. (of this report) UNCLASSIFIED
		15a. DECLASSIFICATION/DOWNGRADING SCHEDULE
16. DISTRIBUTION STATEMENT (of this Report) Approved for public release; distribution unlimited.		
17. DISTRIBUTION STATEMENT (of the abstract entered in Block 20, if different from Report)		
18. SUPPLEMENTARY NOTES This work was partially funded under AMC NWER/T program element 1W162118AH-75 and by the Defense Nuclear Agency under its Sub- task R99QAXEB088, "EMP Interaction and Coupling," Work Unit 51, Source-Region Coupling."		
19. KEY WORDS (Continue on reverse side if necessary and identify by block number) EMP Tactical nuclear threats Interaction phenomena in an EMP source region Compton current density EMP response of a sphere		
20. ABSTRACT (Continue on reverse side if necessary and identify by block number) Electromagnetic effects on ground-based military systems involved in tactical nuclear warfare will be engendered by ionizing radiation, a current density of Compton-recoil elec- trons in the air, and a nonlinear air conductivity. Many of these systems contain conducting enclosures of one form or another that may house susceptible electronic subsystems. Consequently, the electromagnetic responses of such enclosures		

DD FORM 1 JAN 73 1473 EDITION OF 1 NOV 65 IS OBSOLETE

1 UNCLASSIFIED
SECURITY CLASSIFICATION OF THIS PAGE (When Data Entered)

UNCLASSIFIED

SECURITY CLASSIFICATION OF THIS PAGE(When Data Entered)

to tactical nuclear threats could be significant in vulnerability assessments of critical equipment. The objective of the work discussed in this report was to develop physical intuition and analytical approximations that would be useful in these assessments.

Emphasis is placed on the analytical description of the salient physical phenomena that may dominate the electromagnetic response of an ideal "gamma-thin" obstacle subjected to a tactical nuclear threat. The charge and current on a gamma-thin conducting sphere over a ground plane were determined via the following analyses: (a) an early-time analysis wherein the ground plane is ignored and the transient air conductivity is replaced by an average value over an interval, and (b) a late-time analysis wherein the ground plane is accounted for and conduction current is assumed to dominate displacement current in the air. In both analyses, the Compton-current density and the transient air conductivity were taken to be independent of the obstacle.

In the early-time approximation, the total charge on the sphere was found to be identical to the total charge that would have been present in the volume of conducting medium excluded by the sphere. Furthermore, when the sphere was small enough, its polar surface current was shown to exactly cancel the corresponding flow of source current in the air at the sphere's surface.

In the late-time approximation, the total charge on the sphere was shown to comprise an induced charge, which is not zero because of the presence of the ground plane, and a deposited charge, which gives rise to the sphere's potential. Knowledge of the quasi-static surface charge density was used for determination of the total polar current flow on the sphere in the steady state. For consistency in the late-time approximation, the total charge on the sphere was found to be proportional to the time derivative of the Compton-current density, thereby leading to a specification of the sphere's potential with respect to that of the ground plane.

CONTENTS

	<u>Page</u>
1. INTRODUCTION	5
2. APPROACH	6
3. EARLY-TIME APPROXIMATION	9
4. LATE-TIME APPROXIMATION	16
5. CONCLUSION	23
ACKNOWLEDGEMENT	24
LITERATURE CITED	25
APPENDIX A. THE ELECTROMAGNETIC FIELD DUE TO THE SOURCE-CURRENT DENSITY	27
APPENDIX B. BISPHERICAL COORDINATES	29
APPENDIX C. DIFFERENTIAL EQUATION FOR SURFACE CURRENT	33
APPENDIX D. TOTAL CHARGE ON THE SPHERE	37
APPENDIX E. TOTAL CHARGE ON A SEGMENT OF THE SPHERE'S SURFACE	41
DISTRIBUTION	43

FIGURES

1	A perfectly conducting sphere subjected to a source-current density in an ambient conducting medium of infinite extent	10
2	A perfectly conducting sphere over a ground plane subjected to a source-current density and uniform electric field in a transiently conducting ambient medium	16
B-1	Constant coordinate surfaces for the bispherical coordinate system	30

1. INTRODUCTION

The detonation of a nuclear weapon near the earth's surface yields neutrons, x rays, and gamma rays, which all interact with the air, ground, and other matter. The interaction of prompt gamma rays from the weapon with air molecules produces Compton-recoil electrons, each of which, in turn, produces thousands of secondary electrons via collisions with other air molecules. The source-current density composed of these Compton-recoil electrons and the air conductivity arising from the secondary electrons govern, in general, the generation of the electromagnetic pulse (EMP) at ranges where x-ray contributions are insignificant. At later times, air-inelastic and ground-capture collisions of neutrons provide the dominant source of gamma rays for production of Compton-recoil electrons.

The electromagnetic response of a military system in a source region of a nuclear weapon is quite complex, due to several interrelated factors: (a) the presence of ionizing radiation, a current density of Compton-recoil electrons, and a time-varying air conductivity; (b) the "near-zone" character of the source-region electromagnetic field in contrast with radiated plane-wave character; and (c) time histories of field components (in the presence of ground) with significant spectral content from 0 to about 100 MHz. The interaction of ionizing radiation with the system itself produces local sources that also contribute to the electromagnetic field that ultimately drives the system.

The scope of the present study is now delimited since extrinsic currents and voltages appearing in the circuits of a system may be produced by at least three nuclear weapon effects: system-generated EMP (SGEMP), EMP, and internal EMP (IEMP). For the purpose at hand, SGEMP effects on a system are associated with charge and current on the exterior surface of the system, due solely to the direct interaction of ionizing radiation (x rays, gamma rays) with the system itself. EMP effects on a system in the Compton-current region are associated with induced charge and current on the exterior surface of the system due to the interaction of electromagnetic fields with the system in the presence of a nonlinear, time-varying air conductivity. Lastly, IEMP effects on a system result from the penetration of ionizing radiation into a cavity within the system. This radiation produces an internal Compton-current density, which, in turn, gives rise to localized electromagnetic fields in the cavity. Attention is focussed here on EMP interaction phenomena that must be understood if the electromagnetic responses of military systems involved in tactical scenarios are to be assessed. Hopefully, this effort will contribute to the definition and evaluation of dominant EMP interaction phenomena associated with system configurations and environments peculiar to tactical scenarios.

The purpose of this paper is to analytically describe salient physical phenomena that dominate the electromagnetic response of an idealized gamma-thin system subjected to close-in EMP environments of tactical interest. Regarding the nature of tactical threats, since tactical operations involve men and equipment, man's susceptibility is the predominant factor that governs the levels of most nuclear weapon environments of interest in tactical warfare. This predominance is necessitated by the following considerations: (1) Man is relatively susceptible to most nuclear weapon environments, and this susceptibility is relatively invariant. (2) If man can survive all of the nuclear weapon environments associated with a given threat, the equipment he operates should also survive these environments. That is, if certain nuclear weapon environments, e.g., the blast wave or total radiation dose, are severe enough to kill all personnel able to operate the equipment, then the corresponding EMP effects on that equipment are not of interest. On the other hand, EMP effects on equipment should be evaluated for the worst-case EMP environment that is compatible with those nuclear weapon environment criteria that govern man's survivability. Specific magnitudes and time histories for EMP environments associated with specific tactical threats are not presented here. However, assumptions in this study were motivated by characteristics of these environments, which are described in general terms, as the need arises.

2. APPROACH

Early theoretical efforts¹⁻³ concerning EMP interaction with a conducting body in a Compton-current source region were, perforce, numerical. The conducting body was treated as a scatterer of the incident electromagnetic field that would have been present in the absence of the body. The scatterer was immersed in a transient air conductivity that was also assumed to be that present in the absence of the body. Maxwell's equations for the scattered fields, in the presence of the time-varying air conductivity, were solved numerically by a finite-difference technique or an eigenvalue technique with the boundary conditions at the surface of the body. This work was directed at missiles in flight that traverse the high-altitude Compton-current

¹C. D. Taylor, D. H. Lam and T. H. Shumpert, *Electromagnetic Scattering in Time Varying, Inhomogeneous Media, Interaction Note 41, Air Force Weapons Laboratory, Kirtland Air Force Base, NM (15 November 1968).*

²P. P. Toullos, *Missile Flying through a High-Altitude Source Region, Interaction Note 58, Air Force Weapons Laboratory, Kirtland Air Force Base, NM (19 February 1970).*

³D. E. Merewether, *Time Varying Air Conductivity--Results, Interaction Note 59, Air Force Weapons Laboratory, Kirtland Air Force Base, NM (19 February 1970).*

source region resulting from an exoatmospheric nuclear burst. The Compton current was accounted for in these studies through the incident fields. Furthermore, the presence of a ground plane was not necessary for the intended applications.

Kennedy⁴ employed the assumptions of Taylor and Toullos to calculate induced currents on a plane and a sphere. That is, incident fields were scattered from the obstacle in the presence of a time-varying air conductivity. Time histories of the currents were analyzed in two distinct phases: (a) wave phase, wherein displacement current dominates conduction current, and (b) diffusion phase, wherein conduction current dominates displacement current. Toullos' eigenvalue technique provided solutions in the wave phase (early times and low air conductivity), whereas solutions in the diffusion phase (later times and higher air conductivity) were obtained from a diffusion equation for the magnetic field by use of Laplace transforms. Kennedy's results indicated that as the skin depth in the air became small with respect to the obstacle's radius of curvature, the induced current became less dependent on the geometry of the obstacle. Although useful physical insight of this kind came out of the study, numerical results and conclusions were directed at hardened strategic systems expected to survive source-region EMP environments which are much more severe than those for unhardened tactical systems. Consequently, late-time responses of obstacles in proximity to ground due to tactical threats were beyond the scope of Kennedy's efforts.

The steady-state response of a conducting, gamma-thick prolate spheroid in a high-altitude EMP source region has been analytically investigated by Mo.⁵ Laplace's equation for the electrostatic problem of a charged spheroid immersed in a uniform field is solved by separation of variables and application of the boundary conditions. This charge on the prolate spheroid is assumed to be due solely to the Compton current that is collected by the obstacle's exposed surface area during the relaxation time of the ambient conducting medium. The spheroid is immersed in the saturated electric field that gives rise to a conduction current in the medium that just cancels the Compton current; that is, no magnetic field (driven by the currents in the medium) is present in the absence of the obstacle. The total electric field in the presence of the prolate spheroid, however, does drive a magnetic field, which, in turn, engenders a surface current on the obstacle; a differential equation for this steady-state surface current

⁴R. C. Kennedy, *Currents Induced on a Plane and Sphere Immersed in a Time-Varying Conductive Medium*, Interaction Note 127, Air Force Weapons Laboratory, Kirtland Air Force Base, NM (26 April 1972).

⁵T. C. Mo, *Analysis of the Response of a Conductor Immersed in an EMP Source Region--The Steady State*, RDA-TR-2301-009, R&D Associates, Santa Monica, CA (24 January 1975).

is presented and solved by Mo. Analytical and numerical results for the steady-state surface charge and current densities are derived and discussed for a missile-like body subjected to typical threat levels of EMP environments in a high-altitude source region. The steady-state approach, as applied by Mo, is also used in the present study to generate a late-time approximation for a gamma-thin sphere over a ground plane.

Recently, considerable attention has been devoted to direct numerical solution of Maxwell's equations with the appropriate Compton currents that are produced by the interaction of gamma rays with the air, ground, and obstacle.⁶ Two- and three-dimensional numerical calculations for various obstacles, with and without the presence of the ground, have been made for strategic systems/subsystems subjected to relatively high radiation levels. Such finite-difference numerical treatments are feasible and, indeed, quite appropriate for the intended applications because of at least two factors: (a) the high conductivity of the ambient medium about the obstacle and (b) the time frame of concern. For high air conductivity, the electromagnetic response of the obstacle is due primarily to local Compton currents in a relatively small volume about the obstacle; namely, a small skin depth in the ambient medium implies that "local effects dominate" the response of the obstacle. Consequently, if only early-time responses are of concern, an outer boundary condition can be implemented in a numerical approach that does not necessitate excessive computer memory. The efficacy of such an approach for unhardened tactical systems must yet be demonstrated, particularly since the time frame of concern may extend into milliseconds.

In this study, as well as in most of the work reviewed above, the Compton-current density and the transient air conductivity were assumed to be independent of the obstacle. Implicit in this assumption are several ramifications that may or may not significantly distort the physics of EMP interaction phenomena for tactical situations of concern. That is, a conductor subjected to bombardment by Compton-recoil electrons emits electrons back into the ambient transient plasma through various elastic and inelastic scattering reactions in the metal surface. Therefore, in general, a region of highly nonuniform conductivity exists close to the conductor. For simplicity, the existence of such a transient boundary layer is specifically ignored here. Furthermore, if the source region is indeed unperturbed by the obstacle, motions of Compton-recoil electrons and the mobility of secondary electrons are necessarily independent of the obstacle's contribution to the total electromagnetic field. That is, under these conditions, the reactive or

⁶S. J. Dalich, B. C. Goplen, and E. R. Parkinson, *Analysis of Close-in Coupling Effects*, SAI74-509-AQ, Science Applications, Inc., Albuquerque, NM (September 1974).

scattered electromagnetic field due to the presence of the obstacle can be determined in the classical manner. In view of the above considerations, the assumption of an unperturbed source region is clearly a convenience, rather than a justifiable premise, and EMP interaction phenomena associated with tactical engagements must be analyzed more rigorously, so that the validity of such a supposition can be delimited.

Even though the Compton-current density and the transient air conductivity are taken to be independent of an obstacle, numerical or analytical solution of a boundary-value problem involving an obstacle over a ground plane (with or without the presence of transient air conductivity) is still a rather formidable task. So, for useful approximations and development of physical intuition, additional assumptions are necessary to render such a problem analytically tractable. The following analyses were conducted in this vein: (a) an early-time analysis, wherein the ground plane is ignored and the transient air conductivity is replaced by an average value over an interval, and (b) a late-time analysis, wherein the ground plane is accounted for and conduction current is assumed to dominate displacement current in the air. In general, one would expect the early-time approximation to break down at times later than the minimum transit time required for electromagnetic radiation from surface current on the obstacle to scatter from the ground plane and illuminate the observation point. Similarly, one would expect the late-time approximation to break down at early times when displacement current in the air and the time derivative of the magnetic field are significant. An accurate numerical solution to the problem at hand is necessary so that the limits of validity for these approximations can be quantitatively established.

3. EARLY-TIME APPROXIMATION

A perfectly conducting sphere of radius "a" can be considered imbedded in a finitely conducting medium of infinite extent that is characterized by the electrical parameters $\langle \sigma \rangle$ (a time- and space-averaged conductivity) and ϵ_0 (the permittivity of free space). If $\sigma(\vec{r}, t)$ is the transient air conductivity (in the absence of any obstacle) for an actual tactical EMP threat of concern, then

$$\langle \sigma \rangle = \frac{1}{VT} \int_V \int_T \sigma(\vec{r}, t) d\vec{r} dt ,$$

where T is typically the maximum time of validity for our early-time approximation and V is of the order of the obstacle's volume. Since $\sigma(\vec{r}, t)$ is essentially uniform in space over the dimensions of typical tactical equipment, $\langle \sigma \rangle$ reduces to a simple average over a time

interval. Accounting for conduction currents in the ambient medium via the above simplification facilitates analytical treatment and, hopefully, does not preclude adequate engineering estimates for many practical purposes.

As depicted in figure 1, a perfectly conducting sphere is subjected to a current density of Compton-recoil electrons, $\vec{j}(\vec{r},t)$, which flows through the ambient conducting medium at a velocity v (which is nearly c , the velocity of light in free space, because of the average energy of the Compton-recoil electrons). This Compton-current density is assumed to be uniform in the xy plane and to flow unattenuated in the direction of increasing values of z :

$$\vec{j}(\vec{r},t) = \vec{j}(z,t) = f(t - z/v)u(t - z/v) \hat{e}_z, \quad (1)$$

where $f(t)$ is a given time history, \hat{e}_z is a unit vector in the positive z -direction, and

$$u(\xi) = \begin{cases} 1, & \xi > 0 \\ 0, & \xi < 0. \end{cases}$$

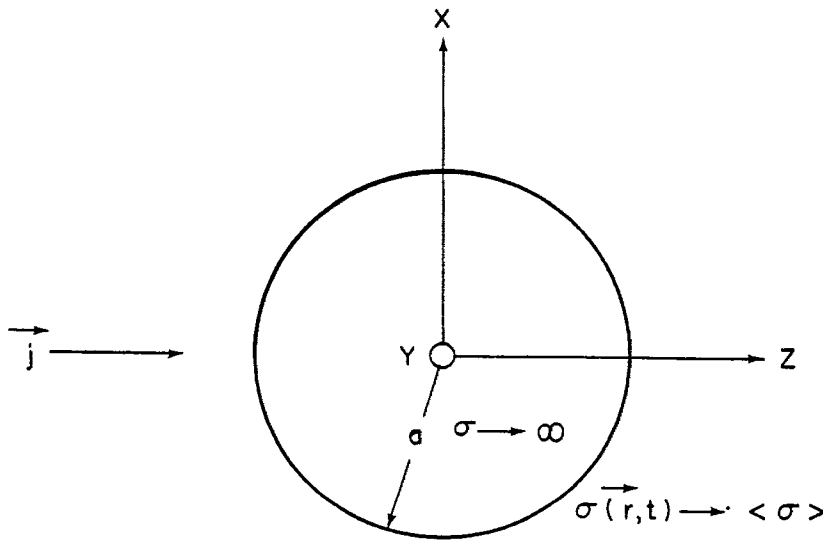

Figure 1. A perfectly conducting sphere subjected to a source-current density in an ambient conducting medium of infinite extent.

Maxwell's equations are as follows for the situation at hand:

$$\vec{\nabla} \times \vec{E}(\vec{r}, t) = - \frac{\partial}{\partial t} \vec{B}(\vec{r}, t) , \quad (2)$$

$$\vec{\nabla} \times \vec{H}(\vec{r}, t) = \vec{j}(\vec{r}, t) + \langle \sigma \rangle \vec{E}(\vec{r}, t) + \frac{\partial}{\partial t} \vec{D}(\vec{r}, t) , \quad (3)$$

$$\vec{\nabla} \cdot \vec{D}(\vec{r}, t) = \rho(\vec{r}, t) , \quad (4)$$

and

$$\vec{\nabla} \cdot \vec{B}(\vec{r}, t) = 0 \quad (5)$$

with the constitutive relation

$$\vec{D} = \epsilon_0 \vec{E} \quad (6)$$

and

$$\vec{B} = \mu_0 \vec{H} . \quad (7)$$

Maxwell's equations in the above form are driven by the source-current density of Compton-recoil electrons; that is, an electromagnetic field does not exist in the absence of the source-current density.

For convenience, the problem is analyzed in the frequency domain, so that the appropriate Fourier integrals must now be introduced, e.g.,

$$\vec{j}(\vec{r}, t) = \frac{1}{2\pi} \int_{-\infty}^{+\infty} \vec{j}(\vec{r}, \omega) e^{-i\omega t} d\omega \quad (8)$$

and

$$\vec{j}(\vec{r}, \omega) = \int_{-\infty}^{+\infty} \vec{j}(\vec{r}, t) e^{+i\omega t} dt = \vec{f}(\omega) e^{+i\omega z/v} \hat{e}_z . \quad (9)$$

A tilde used as an underscore denotes a frequency-domain function. Maxwell's equations in the frequency domain become

$$\vec{\nabla} \times \vec{\tilde{E}}(\vec{r}, \omega) = i\omega\mu_0 \vec{\tilde{H}}(\vec{r}, \omega) , \quad (10)$$

$$\vec{\nabla} \times \vec{\tilde{H}}(\vec{r}, \omega) = \vec{\tilde{j}}(\vec{r}, \omega) + (\langle \sigma \rangle - i\omega\epsilon_0) \vec{\tilde{E}}(\vec{r}, \omega) , \quad (11)$$

$$\vec{\nabla} \cdot \vec{\tilde{E}}(\vec{r}, \omega) = \rho(\vec{r}, \omega) / \epsilon_0 , \quad (12)$$

and

$$\vec{\nabla} \cdot \vec{\tilde{H}}(\vec{r}, \omega) = 0 . \quad (13)$$

In that which follows, analytical solutions of equations (10) to (13) are developed for the appropriate boundary conditions at the surface of the sphere.

As the first consideration, the electromagnetic field (in the absence of any obstacle) arises solely from the source-current density prescribed in equation (9). In the absence of an obstacle, a magnetic field does not exist in the conducting medium (demonstrated in app A); an electric field is present and is thus a consequence of vanishing total current density in the medium. This situation is essentially that described by Cohen⁷ as a "P" (plasma) mode.

The total electromagnetic field arising from the flow of source-current density about our perfectly conducting sphere can be readily determined from equations (10) to (13) by use of spherical vector wave functions. The source-current density can be represented as follows:⁸

$$\vec{\tilde{j}}(\vec{r}, \omega) = \underline{f}(\omega) e^{+i\beta r \cos \theta} \hat{e}_z = \beta^{-1} \underline{f}(\omega) \sum_{n=0}^{\infty} i^{n-1} (2n+1) \vec{\tilde{k}}_n^{(1)}(\beta) , \quad (14)$$

where $\vec{\tilde{k}}_n^{(1)}$ is an irrotational vector given by⁸

$$\vec{\tilde{k}}_n^{(1)}(\beta) = \hat{e}_r P_n(\cos \theta) \frac{\partial}{\partial r} j_n(\beta r) + \hat{e}_\theta \frac{1}{r} j_n(\beta r) \frac{\partial}{\partial \theta} P_n(\cos \theta) . \quad (15)$$

⁷M. H. Cohen, *Radiation in a Plasma. I. Cerenkov Effect*, *Phys. Rev.*, **123**, No. 3 (1 August 1961), 711-721.

⁸J. A. Stratton, *Electromagnetic Theory*, McGraw-Hill, New York (1941), 420.

P_n and j_n are the Legendre polynomial and spherical Bessel function of n th order, respectively. Since the source-current density is irrotational, the magnetic field is a solution of the homogeneous vector Helmholtz equation. Thus, the azimuthally symmetric magnetic field can be expressed as

$$\vec{H}(\vec{r}, \omega) = - (\beta k)^{-1} \underline{f}(\omega) \sum_{n=1}^{\infty} i^{n-1} (2n+1) \left[a_n \vec{n}_n^{(3)}(k) + b_n \vec{m}_n^{(3)}(k) \right], \quad (16)$$

where a_n and b_n must yet be determined through boundary conditions. The undefined vectors in equation (16) are necessarily solenoidal and can be calculated from

$$\vec{m}_n^{(3)}(k) = -\hat{e}_\phi h_n^{(1)}(kr) \frac{\partial}{\partial \theta} P_n(\cos \theta) \quad (17)$$

and

$$\begin{aligned} \vec{n}_n^{(3)}(k) = \hat{e}_r \frac{n(n+1)}{kr} h_n^{(1)}(kr) P_n(\cos \theta) + \\ \hat{e}_\theta \frac{1}{kr} \frac{\partial}{\partial r} \left[r h_n^{(1)}(kr) \right] \frac{\partial}{\partial \theta} P_n(\cos \theta), \end{aligned} \quad (18)$$

with $h_n^{(1)}$ denoting the spherical Hankel function of the first kind.

The coefficient a_n can be evaluated directly from equation (16), since the radial magnetic field must vanish at the surface of the conducting sphere; that is,

$$\hat{e}_r \cdot \vec{H}(r = a, \theta, \omega) = 0 \quad (19)$$

leads to

$$a_n = 0. \quad (20)$$

Apparently, then, the magnetic field is purely azimuthal, and equation (16) reduces to

$$\vec{H}(\vec{r}, \omega) = - (\beta k)^{-1} \underline{f}(\omega) \sum_{n=1}^{\infty} i^{n-1} (2n+1) b_n \vec{m}_n^{(3)}(k). \quad (21)$$

The value of b_n results from the boundary condition on the theta component of electric field,

$$\hat{e}_\theta \cdot \vec{E}(r = a, \theta, \omega) = 0 . \quad (22)$$

By use of the relation

$$\vec{\nabla} \times \vec{m}_n^{(3)}(k) = k \vec{n}_n^{(3)}(k) , \quad (23)$$

equation (11) yields the total electric field:

$$\vec{E}(\vec{r}, \omega) = \vec{E}^i(\vec{r}, \omega) + \vec{E}^s(\vec{r}, \omega) , \quad (24)$$

where

$$\vec{E}^i(\vec{r}, \omega) = - (\langle \sigma \rangle - i\omega\epsilon_0)^{-1} \vec{j}(\vec{r}, \omega) \quad (25)$$

and

$$\vec{E}^s(\vec{r}, \omega) = - (\langle \sigma \rangle - i\omega\epsilon_0)^{-1} \beta^{-1} \underline{f}(\omega) \sum_{n=1}^{\infty} i^{n-1} (2n+1) b_n \vec{n}_n^{(3)}(k) . \quad (26)$$

The solution to our boundary-value problem is, therefore, embodied in

$$b_n = - k j_n(\beta a) \left[\frac{\partial}{\partial r} \left[r h_n^{(1)}(kr) \right] \right]_{r=a}^{-1} . \quad (27)$$

The total charge on the perfectly conducting sphere, Q , can now be calculated from Gauss's flux theorem:

$$Q = \int_0^\pi \int_0^{2\pi} \hat{e}_r \cdot \vec{D}(r = a, \theta, \omega) (a^2 \sin \theta) d\theta d\phi . \quad (28)$$

Similarly, if the sphere is not present, the total charge Q_0 contained in the excluded volume of conducting medium is given by

$$Q_0 = \int_0^\pi \int_0^{2\pi} \hat{e}_r \cdot [\epsilon_0 \vec{E}^i(r = a, \theta, \omega)] (a^2 \sin \theta) d\theta d\phi. \quad (29)$$

Evaluation of the integrals in equations (28) and (29) reveals

$$Q = Q_0 = -4\pi a^2 \epsilon_0 \underline{f}(\omega) [(i\beta) \langle \sigma \rangle - i\omega \epsilon_0]^{-1} \left[\frac{\partial}{\partial r} j_0(\beta r) \right]_{r=a}, \quad (30)$$

so that the total charge on the sphere is identical to the total charge that would be present in the volume of conducting medium excluded by the sphere. If ωa is small compared to v , the charge density in the volume of conducting medium excluded by the sphere (eq (A-2)) is essentially uniform, and Q or Q_0 is simply this uniform charge density times the volume of the sphere.

The surface current on the perfectly conducting sphere, \vec{K} , is defined as

$$\vec{K}(\theta, \omega) = \hat{e}_r \times \vec{H}(r = a, \theta, \omega) = -\underline{H}_\phi(r = a, \theta, \omega) \hat{e}_\theta = K_\theta(\theta, \omega) \hat{e}_\theta, \quad (31)$$

such that

$$K_\theta(\theta, \omega) = \beta^{-1} \underline{f}(\omega) \sum_{n=1}^{\infty} i^{n-1} (2n+1) h_n^{(1)}(ka) \left[\frac{\partial}{\partial r} [r h_n^{(1)}(kr)] \right]^{-1} \cdot j_n(\beta a) \frac{\partial}{\partial \theta} P_n(\cos \theta). \quad (32)$$

If both $|ka|$ and $|\beta a|$ are small compared to unity, the following small argument approximations are useful:

$$\frac{d}{du} [u h_n^{(1)}(u)] \rightarrow -n h_n^{(1)}(u)$$

and

$$j_n(u) \rightarrow u^n / [1 \cdot 3 \cdot 5 \dots (2n-1)(2n+1)]$$

for $|u| \ll 1$. By use of these approximations and only the first term of the sum in equation (32), the surface current reduces to

$$K_{\theta}(\theta, \omega) \rightarrow -a[-\underline{f}(\omega) \sin \theta] = -a \underline{j}_{\theta}(r = a, \theta, \omega) . \quad (33)$$

At long wavelengths, then, a surface current on the sphere is established that exactly cancels corresponding Compton-current flow in the air.

4. LATE-TIME APPROXIMATION

EMP environments of tactical interest in Compton-current source regions exhibit, in general, steady-state or quasi-stationary behavior for times greater than about 1 μ sec. That is, time histories of typical electromagnetic fields and transient air conductivities decay slowly. So at these later times, total conduction current in the air dominates displacement current. Furthermore, the predominant components of a typical late-time electromagnetic field at or near the earth's surface are the vertical electric field and horizontal magnetic field. The transient air conductivity is essentially uniform in volumes of practical concern. These considerations constitute the physical basis for the analytical formulation and subsequent results developed below.

In figure 2, a perfectly conducting sphere, at a height h above a perfectly conducting ground plane, is immersed in a uniform, transient

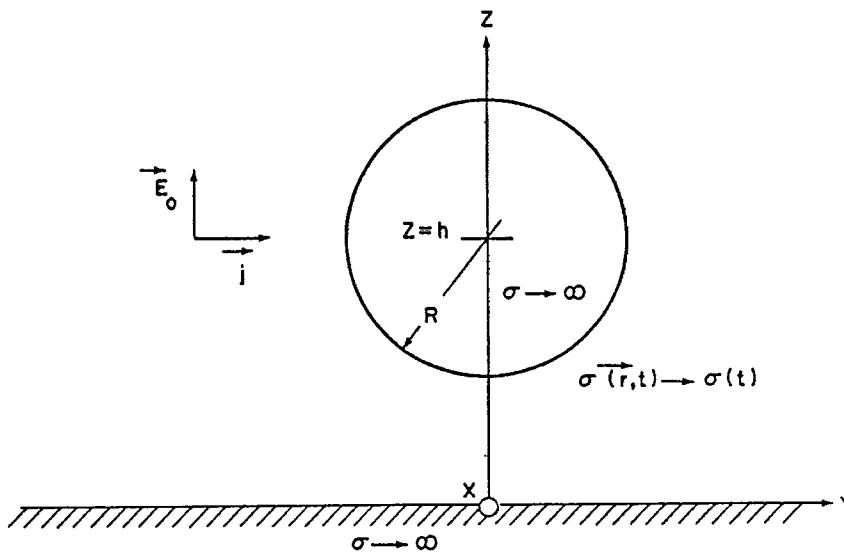

Figure 2. A perfectly conducting sphere over a ground plane subjected to a source-current density and uniform electric field in a transiently conducting ambient medium.

air conductivity and subjected to a current density of Compton-recoil electrons, $\vec{j}(\vec{r}, t)$. This current density flows in the positive y-direction at velocity v and is assumed to be uniform in the xz plane:

$$\vec{j}(\vec{r}, t) = f(t - y/v)u(t - y/v)\hat{e}_y . \quad (34)$$

In contradistinction to the previous early-time approximation, the source-current density flows in a direction transverse to the z axis of the sphere in this analysis.

Maxwell's equations for quasi-stationary electromagnetic fields and the Compton-current density specified in equation (34) take the form

$$\vec{\nabla} \times \vec{E}(\vec{r}, t) = 0 , \quad (35)$$

$$\vec{\nabla} \times \vec{H}(\vec{r}, t) = \vec{j}(\vec{r}, t) + \sigma(t)\vec{E}(\vec{r}, t) , \quad (36)$$

$$\vec{\nabla} \cdot \vec{E}(\vec{r}, t) = \rho(\vec{r}, t)/\epsilon_0 , \quad (37)$$

and

$$\vec{\nabla} \cdot \vec{H}(\vec{r}, t) = 0 . \quad (38)$$

The Compton-current density, transient air conductivity, and charge density are all assumed to be known in the absence of the sphere, but only the first two must be specified explicitly. Our objective is to determine the surface charge density, total charge, and surface current on the sphere in the presence of a perfectly conducting ground plane. To achieve this objective, equations (35) to (38) are solved by use of bispherical coordinates as described in appendix B.

The electric field in equations (35) to (37) can be represented as the sum of a primary field due solely to volume charge density in the air, \vec{E}_0 , and a secondary electric field due only to surface charge density on the sphere, \vec{E}_s :

$$\vec{E}(\vec{r}, t) = \vec{E}_0(\vec{r}, t) + \vec{E}_s(\vec{r}, t) . \quad (39)$$

The primary field is a solution of

$$\vec{\nabla} \times \vec{E}_0(\vec{r}, t) = 0 \quad (40)$$

and

$$\vec{\nabla} \cdot \vec{E}_0(\vec{r}, t) = \rho(\vec{r}, t)/\epsilon_0, \quad (41)$$

whereas the secondary field is a solution of

$$\vec{\nabla} \times \vec{E}_s(\vec{r}, t) = 0 \quad (42)$$

and

$$\vec{\nabla} \cdot \vec{E}_s(\vec{r}, t) = 0. \quad (43)$$

The primary and secondary fields are derivable from scalar potential functions, i.e.,

$$\vec{E}_0(\vec{r}, t) = -\vec{\nabla}\psi_0(\vec{r}, t) \quad (44)$$

and

$$\vec{E}_s(\vec{r}, t) = -\vec{\nabla}\psi_s(\vec{r}, t), \quad (45)$$

which, in turn, can be obtained from

$$\nabla^2\psi_0(\vec{r}, t) = -\rho(\vec{r}, t)/\epsilon_0 \quad (46)$$

and

$$\nabla^2\psi_s(\vec{r}, t) = 0 \quad (47)$$

with the appropriate boundary conditions. The surface charge density and the resultant total charge on the sphere follow directly, then, from knowledge of these potential functions.

The magnetic field can be obtained from knowledge of the electric field via equations (36) and (38). Knowledge of the magnetic field everywhere in space, however, is not necessary to determine surface current on the sphere. As is demonstrated in appendix C, equation (36) can be reduced to a differential equation that specifies the sphere's surface current in terms of the normal component of the total current density at the sphere's surface. So once the electric field is known, the surface current on the sphere can be obtained by integration of

$$\begin{aligned} h_{\eta}^{-1}(\mu_0, \eta) h_{\phi}^{-1}(\mu_0, \eta) \frac{\partial}{\partial \eta} [h_{\phi}(\mu_0, \eta) K_{\eta}(\eta, \phi, t)] \\ = j_{\mu}(\mu_0, \eta, \phi, t) + \sigma(t) E_{\mu}(\mu_0, \eta, t) , \end{aligned} \quad (48)$$

where K_{η} is assumed to be the only component of surface current.

Regarding the primary electric field and its adequate representation for this study, the late-time approximation, knowledge of the volume charge density in the air allows a determination of the primary electrostatic potential, by use, for instance, of the electrostatic Green's function for an infinite ground plane. State-of-the-art numerical predictions of close-in EMP environments of tactical interest, however, indicate that the primary electric field is principally vertical to the ground plane, particularly at times beyond 1 μ sec. Furthermore, this primary vertical electric field is taken to be essentially uniform over spherical volumes of concern here:

$$\psi_0(\vec{r}, t) \rightarrow -E_0(t)z = -E_0(t)a \sinh \mu (\cosh \mu - \cos \eta)^{-1} \quad (49)$$

as $\mu \rightarrow \mu_0$, where $E_0(t)$ is a known function of time.

For azimuthal symmetry, a solution of equation (47) for the secondary electric field is of the form⁹

$$\begin{aligned} \psi_s(\vec{r}, t) = (\cosh \mu - \cos \eta)^{\frac{1}{2}} \sum_{n=0}^{\infty} \{A_n(t) \exp[(n + \frac{1}{2})\mu] \\ + B_n(t) \exp[-(n + \frac{1}{2})\mu]\} P_n(\cos \eta) , \end{aligned} \quad (50)$$

where A_n and B_n must be determined from boundary conditions on the total electrostatic potential. Denoting the total potential by Ψ , viz.,

⁹P. M. Morse and H. Feshbach, *Methods of Theoretical Physics*, McGraw-Hill, New York (1953), 1299.

$$\Psi(\vec{r}, t) = \Psi_0(\vec{r}, t) + \Psi_s(\vec{r}, t), \quad (51)$$

the boundary condition at the ground plane is

$$\Psi(0, \eta, t) = 0, \quad (52)$$

whereas the sphere is taken to be at a known potential $V(t)$,

$$\Psi(\mu_0, \eta, t) = V(t). \quad (53)$$

$V(t)$ is due to total charge induced on the sphere by $E_0(t)$ and charge collected by the sphere from the air.

Equation (52), with equations (49) to (51), leads to

$$B_n(t) = -A_n(t) = -V_n(t)/2 \quad (54)$$

so that

$$\Psi_s(\vec{r}, t) = (\cosh \mu - \cos \eta)^{1/2} \sum_{n=0}^{\infty} V_n(t) \sinh [(n + 1/2)\mu] P_n(\cos \eta). \quad (55)$$

The remaining boundary condition can be implemented with the aid of the following identity:

$$(\cosh \mu_0 - \cos \eta)^{-1/2} = \sqrt{2} \sum_{n=0}^{\infty} \exp[-(n + 1/2)\mu_0] P_n(\cos \eta), \quad (56)$$

where μ_0 is positive. By equation (53),

$$\sum_{n=0}^{\infty} V_n(t) \sinh [(n + 1/2)\mu_0] P_n(\cos \eta) = \left[V(t) - 2E_0(t)a \frac{\partial}{\partial \mu_0} \right] (\cosh \mu_0 - \cos \eta)^{-1/2}$$

and, therefore,

$$V_n(t) = \sqrt{2} [E_0(t)a(2n + 1) + V(t)] \exp[-(n + 1/2)\mu_0] / \sinh [(n + 1/2)\mu_0]. \quad (57)$$

The surface charge density on the sphere, $\rho_s(\eta, t)$, can now be specified as

$$\begin{aligned} \rho_s(\eta, t) = & -\epsilon_0 E_\mu(\mu_0, \eta, t) = (\epsilon_0/a) \{-E_0(t)a \cosh \mu_0 \\ & + [V(t)/2] \sinh \mu_0 + [3E_0(t)a/2] \sinh^2 \mu_0 (\cosh \mu_0 - \cos \eta)^{-1} \\ & + (\cosh \mu_0 - \cos \eta)^{3/2} \sum_{n=0}^{\infty} V_n(t) (n + \frac{1}{2}) \cosh [(n + \frac{1}{2})\mu_0] P_n(\cos \eta) \} , \end{aligned} \quad (58)$$

since the outward-directed normal to the conducting sphere at $\mu = \mu_0 > 0$ is as defined in equation (C-10). This surface charge density is integrated over the entire surface of the sphere in appendix D for the total charge, Q_{sphere} :

$$Q_{\text{sphere}}(t) = Q_i(t) + Q_d(t) , \quad (59)$$

where Q_i is the total induced charge,

$$Q_i(t) = 8\pi\epsilon_0 a^2 E_0(t) \sum_{n=0}^{\infty} (2n + 1) / \{\exp[(2n + 1)\mu_0] - 1\} , \quad (60)$$

and Q_d is the total deposited charge,

$$Q_d(t) = 8\pi\epsilon_0 a V(t) \sum_{n=0}^{\infty} \{\exp[(2n + 1)\mu_0] - 1\}^{-1} . \quad (61)$$

The total induced charge on the sphere is nonzero because of the presence of the conducting ground plane. The induced charge on the ground plane due to the presence of the sphere, in turn, is clearly equal in magnitude and opposite in sign to the total charge on the sphere.

All that remains to be done in our late-time approximation is the determination of the surface current on the sphere by use of equation (48). Instead of actual determination of the surface current per se, convenience motivates solving for the total current flow across a circle on the sphere that circumscribes a plane area parallel to the ground plane:

$$I_\eta(\eta, t) = \int_0^{2\pi} K_\eta(\eta, \phi, t) h_\phi(\mu_0, \eta) d\phi . \quad (62)$$

Since the surface current must be finite at all points on the sphere, the total current defined in equation (62) must vanish at the poles, namely,

$$I_{\eta}(0, t) = I_{\eta}(\pi, t) = 0 . \quad (63)$$

Integration of equation (48) and use of equations (62) and (63) leads to

$$I_{\eta}(\eta, t) = \int_0^{\eta} \int_0^{2\pi} j_{\mu}(\mu_0, \eta, \phi, t) h_{\eta}(\mu_0, \eta) h_{\phi}(\mu_0, \eta) d\eta d\phi - [\sigma(t)/\epsilon_0] Q(\eta, t) , \quad (64)$$

where

$$Q(\eta, t) = \int_0^{\eta} \int_0^{2\pi} \rho_S(\eta, t) h_{\eta}(\mu_0, \eta) h_{\phi}(\mu_0, \eta) d\eta d\phi . \quad (65)$$

The total charge on only a portion of the sphere's surface, $Q(\eta, t)$, is evaluated explicitly in appendix E, but

$$Q(\pi, t) = Q_{\text{sphere}}(t) . \quad (66)$$

Since $t > y(\mu_0, \eta, \phi)/v$ for situations of interest, the μ component of the Compton-current density at the surface of the sphere can be expanded as

$$\begin{aligned} j_{\mu}(\mu_0, \eta, \phi, t) = & - \frac{Y(\mu_0, \eta, \phi)}{R} f(t) \\ & - \frac{Y(\mu_0, \eta, \phi)}{v} \frac{df(t)}{dt} \\ & + \frac{1}{2} \left[- \frac{Y(\mu_0, \eta, \phi)}{v} \right]^2 \frac{d^2 f(t)}{dt^2} + \dots , \end{aligned} \quad (67)$$

where R , as defined in appendix B, is the radius of the sphere. The Compton-current density also decays slowly at later times, so that only the first derivative in equation (67) contributes significantly to the integration in equation (64); consequently,

$$I_{\eta}(\eta, t) = \frac{1}{v} \frac{df(t)}{dt} \tau(\eta) - [\sigma(t)/\epsilon_0] Q(\eta, t) , \quad (68)$$

where

$$\tau(\eta) = \frac{1}{R} \int_0^\eta \int_0^{2\pi} Y^2(\mu_0, \eta, \phi) h_\eta(\mu_0, \eta) h_\phi(\mu_0, \eta) d\eta d\phi$$

or

$$\begin{aligned} \tau(\eta) = \pi a^4 R^{-1} \{ & [-(1/3) \sinh^2 \mu_0 + (\cosh \mu_0 - 1)] (\cosh \mu_0 - 1)^{-3} \\ & + [(1/3) \sinh^2 \mu_0 - \cos \eta (\cosh \mu_0 - \cos \eta)] (\cosh \mu_0 - \cos \eta)^{-3} \} \end{aligned} \quad (69)$$

For consistency in the late-time approximation, the total charge on the sphere (and thus the sphere's potential $V(t)$) must be defined through equation (68) at $\eta = \pi$:

$$\frac{1}{v} \frac{df(t)}{dt} = \sigma(t) Q_{\text{sphere}}(t) / \epsilon_0 \tau_{\text{sphere}} \quad (70)$$

with

$$\tau_{\text{sphere}} = \tau(\pi) = 4\pi R^3/3 . \quad (71)$$

Hence, the total current becomes, finally,

$$I_\eta(\eta, t) = [Q_{\text{sphere}}(t) \tau(\eta) / \tau_{\text{sphere}} - Q(\eta, t)] / [\epsilon_0 / \sigma(t)] . \quad (72)$$

5. CONCLUSION

Since the source-current density and the conductivity of the ambient medium were assumed to be independent of the obstacle in the early-time approximation, the early-time analytical results were obtained, essentially, by solution of a classical electromagnetic scattering problem. The total charge on the sphere was found to be identical to the total charge that would have been present in the volume of conducting medium excluded by the sphere. Furthermore, if the sphere was small enough, the theta component of surface current on the sphere was shown to exactly cancel the corresponding flow of source current in the air at the sphere's surface.

In the late-time approximation, the surface-charge density on a sphere over a ground plane was obtained by solution of an electrostatic boundary-value problem; this density, in turn, led to the total charge on the sphere in terms of its unspecified potential. The total charge

on the sphere was shown to comprise a total induced charge, which is not zero because of the presence of the ground plane, and a total deposited charge, which engenders the sphere's potential. Knowledge of the surface-charge density was then used to evaluate the total polar current flow on the sphere in the steady state. For consistency in the late-time approximation, the total charge on the sphere was shown to be proportional to the time derivative of the source-current density, thereby leading to a specification of the sphere's potential.

An attempt has been made, therefore, to generate approximate analytical results for the electromagnetic response of a conducting body over a ground plane subjected to source and conduction currents in the air. To the extent that the body is transparent to 1- or 2-MeV gamma rays, the early- and late-time approximations may adequately describe salient interaction phenomena associated with tactical EMP threats to electronic equipment housed in conducting enclosures aboveground. Finally, as pointed out previously, an accurate numerical solution, experimental data for the problem treated here, or both must be obtained for comparisons, so that the limits of validity can be quantitatively established for the early- and late-time approximations.

ACKNOWLEDGEMENT

The author thanks Daniel J. Spohn of the Harry Diamond Laboratories for many helpful discussions concerning electromagnetic environments associated with tactical nuclear threats to Army equipment.

LITERATURE CITED

- (1) C. D. Taylor, D. H. Lam and T. H. Shumpert, Electromagnetic Scattering in Time Varying, Inhomogeneous Media, Interaction Note 41, Air Force Weapons Laboratory, Kirtland Air Force Base, NM (15 November 1968).
- (2) P. P. Toullos, Missile Flying through a High-Altitude Source Region, Interaction Note 58, Air Force Weapons Laboratory, Kirtland Air Force Base, NM (19 February 1970).
- (3) D. E. Merewether, Time Varying Air Conductivity--Results, Interaction Note 59, Air Force Weapons Laboratory, Kirtland Air Force Base, NM (19 February 1970).
- (4) R. C. Kennedy, Currents Induced on a Plane and Sphere Immersed in a Time-Varying Conductive Medium, Interaction Note 127, Air Force Weapons Laboratory, Kirtland Air Force Base, NM (26 April 1972).
- (5) T. C. Mo, Analysis of the Response of a Conductor Immersed in an EMP Source Region--The Steady State, RDA-TR-2301-009, R&D Associates, Santa Monica, CA (24 January 1975).
- (6) S. J. Dalich, B. C. Goplen, and E. R. Parkinson, Analysis of Close-in Coupling Effects, SAI74-509-AQ, Science Applications, Inc., Albuquerque, NM (September 1974).
- (7) M. H. Cohen, Radiation in a Plasma. I. Cerenkov Effect, Phys. Rev., 123, No. 3 (1 August 1961), 711-721.
- (8) J. A. Stratton, Electromagnetic Theory, McGraw-Hill, New York (1941), 420.
- (9) P. M. Morse and H. Feshbach, Methods of Theoretical Physics, McGraw-Hill, New York (1953), 1299.

APPENDIX A. THE ELECTROMAGNETIC FIELD DUE TO THE SOURCE-CURRENT DENSITY

Equations (10) to (12) in the body of this report can be manipulated in the usual manner to yield the following inhomogeneous vector Helmholtz equation:

$$\nabla^2 \vec{E}(\vec{r}, \omega) + k^2 \vec{E}(\vec{r}, \omega) = -i\omega\mu_0 \vec{j}(\vec{r}, \omega) + \frac{1}{\epsilon_0} \vec{\nabla} \rho(\vec{r}, \omega) , \quad (\text{A-1})$$

where

$$k^2 = i\omega\mu_0 (\langle \sigma \rangle - i\omega\epsilon_0) .$$

The charge density appearing in equation (A-1) can be obtained from the divergence of equation (11) and is given by

$$\rho(\vec{r}, \omega) = \rho(z, \omega) = \frac{-i\beta}{(\langle \sigma \rangle / \epsilon_0 - i\omega)} j(z, \omega) , \quad (\text{A-2})$$

where

$$\beta = \omega/v .$$

Since the source-current density is in the z-direction and depends only on z, equation (A-1) becomes

$$\frac{d^2}{dz^2} E_z(z, \omega) + k^2 E_z(z, \omega) = -i\omega\mu_0 (1 - \beta^2/k^2) j(z, \omega) , \quad (\text{A-3})$$

and it is easy to demonstrate that the solution of this equation is

$$E_z(z, \omega) = - \frac{i\omega\mu_0}{k^2} j(z, \omega) . \quad (\text{A-4})$$

Substitution of this electric field into equation (10) yields a magnetic field that is identically zero.

APPENDIX B. BISPHERICAL COORDINATES

The bispherical coordinate system is described in many books on mathematical physics and electromagnetic theory. Bispherical and many other orthogonal coordinate systems, with informative applications to electromagnetics, are discussed thoroughly by Moon and Spencer.¹ If the z-axis is the axis of rotation for a bispherical system, rectangular coordinates (x,y,z) can be expressed in terms of bispherical coordinates (μ, η, ϕ) as follows:

$$\left. \begin{aligned} x &= a \sin \eta \cos \phi (\cosh \mu - \cos \eta)^{-1} , \\ y &= a \sin \eta \sin \phi (\cosh \mu - \cos \eta)^{-1} , \\ z &= a \sinh \mu (\cosh \mu - \cos \eta)^{-1} , \end{aligned} \right\} \quad (B-1)$$

where $\pm a$ are points on the z-axis corresponding to $\mu = \pm\infty$ and

$$\left. \begin{aligned} -\infty &\leq \mu \leq +\infty , \\ 0 &\leq \eta \leq \pi , \\ 0 &\leq \phi < 2\pi . \end{aligned} \right\} \quad (B-2)$$

Surfaces for constant coordinate values in the bispherical systems are shown in figure B-1; a sphere with its center on the z-axis can be generated when μ is a constant, an apple-shaped or spindle-shaped surface results when η is a constant, and a meridian plane corresponds to a constant value of ϕ . The xy plane also is a constant coordinate surface in the bispherical system (i.e., $\mu = 0$).

If \vec{r} is the position vector of an arbitrary point in space,

$$\vec{r} = x \hat{e}_x + y \hat{e}_y + z \hat{e}_z , \quad (B-3)$$

¹P. Moon and D. E. Spencer, *Field Theory for Engineers*, D. Van Nostrand (1960), 376-384.

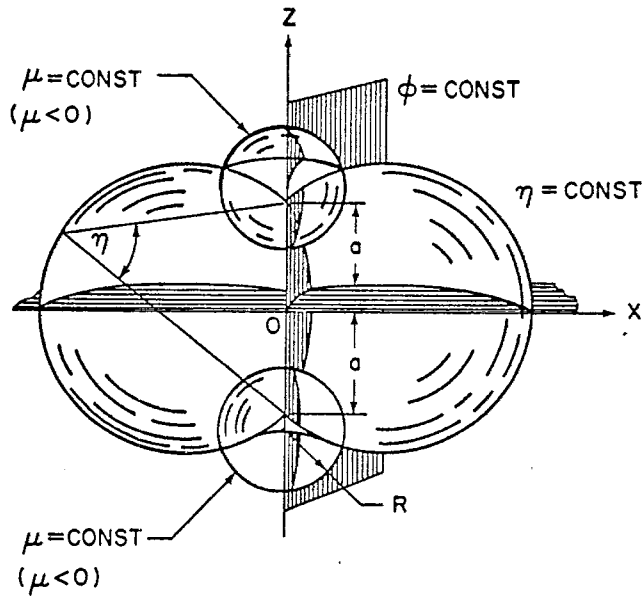

Figure B-1. Constant coordinate surfaces for the bispherical coordinate system.

The unit vectors in the bispherical system can be obtained from

$$\left. \begin{aligned}
 \hat{e}_\mu(\mu, \eta, \phi) &= \frac{\partial \vec{r}}{\partial \mu} \left| \frac{\partial \vec{r}}{\partial \mu} \right|^{-1} = \frac{1}{h_\mu(\mu, \eta)} \frac{\partial \vec{r}}{\partial \mu} , \\
 \hat{e}_\eta(\mu, \eta, \phi) &= \frac{\partial \vec{r}}{\partial \eta} \left| \frac{\partial \vec{r}}{\partial \eta} \right|^{-1} = \frac{1}{h_\eta(\mu, \eta)} \frac{\partial \vec{r}}{\partial \eta} , \\
 \hat{e}_\phi(\mu, \eta, \phi) &= \frac{\partial \vec{r}}{\partial \phi} \left| \frac{\partial \vec{r}}{\partial \phi} \right|^{-1} = \frac{1}{h_\phi(\mu, \eta)} \frac{\partial \vec{r}}{\partial \phi} ,
 \end{aligned} \right\} \quad (B-4)$$

wherein the "scale factors" are readily found to be

$$\begin{aligned}
 h_\mu(\mu, \eta) &= a (\cosh \mu - \cos \eta)^{-1} , \\
 h_\eta(\mu, \eta) &= h_\mu(\mu, \eta) , \\
 h_\phi(\mu, \eta) &= a \sin \eta (\cosh \mu - \cos \eta)^{-1} .
 \end{aligned} \quad (B-5)$$

The unit vectors \hat{e}_μ , \hat{e}_η , and \hat{e}_ϕ are in the directions of increasing values of μ , η , and ϕ , respectively. In particular, if μ is a positive constant, such as μ_0 , $\hat{e}_\mu(\mu_0, \eta, \phi)$ is an inward directed normal to the spherical surface of radius $R = a/\sinh \mu_0$.

The gradient and Laplacian of a scalar function and the divergence and curl of a vector function expressed in general orthogonal curvilinear coordinates are well known.² These general expressions can be readily particularized for bispherical coordinates, as defined in equations (B-1), through the use of equations (B-5).

²See, for instance, Murray R. Spiegel, *Vector Analysis*, Schaum Publishing Co., New York (1959), 137.

APPENDIX C. DIFFERENTIAL EQUATION FOR SURFACE CURRENT

In the absence of displacement current, the magnetic field \vec{H} is related to total conduction current \vec{J} through

$$\vec{\nabla} \times \vec{H}(\vec{r}, t) = \vec{J}(\vec{r}, t) . \quad (C-1)$$

Now let $\hat{n}(\vec{r}_S)$ be an outward-directed normal to a perfectly conducting surface S at a point on that surface denoted by \vec{r}_S . On the perfectly conducting surface, the normal component of the magnetic field vanishes, namely,

$$\hat{n}(\vec{r}_S) \cdot \vec{H}(\vec{r}_S, t) = 0 , \quad (C-2)$$

while the tangential magnetic field gives rise to surface current:

$$\hat{n}(\vec{r}_S) \times \vec{H}(\vec{r}_S, t) = \vec{K}(\vec{r}_S, t) . \quad (C-3)$$

A well-known vector identity provides the relation

$$\vec{\nabla} \cdot [\vec{H}(\vec{r}, t) \times \hat{e}_\mu(\vec{r})] = \hat{e}_\mu(\vec{r}) \cdot [\vec{\nabla} \times \vec{H}(\vec{r}, t)] - \vec{H}(\vec{r}, t) \cdot [\vec{\nabla} \times \hat{e}_\mu(\vec{r})]$$

or, by use of equation (C-1),

$$\vec{\nabla} \cdot [\vec{H}(\vec{r}, t) \times \hat{e}_\mu(\vec{r})] + \vec{H}(\vec{r}, t) \cdot [\vec{\nabla} \times \hat{e}_\mu(\vec{r})] = J_\mu(\vec{r}, t) . \quad (C-4)$$

The gradient can be expressed as

$$\vec{\nabla} = \frac{\hat{e}_\mu(\vec{r})}{h_\mu(\mu, \eta)} \frac{\partial}{\partial \mu} + \vec{\nabla}_{\eta\phi} , \quad (C-5)$$

where

$$\vec{\nabla}_{\eta\phi} = \frac{\hat{e}_\eta(\vec{r})}{h_\eta(\mu, \eta)} \frac{\partial}{\partial \eta} + \frac{\hat{e}_\phi(\vec{r})}{h_\phi(\mu, \eta)} \frac{\partial}{\partial \phi} , \quad (C-6)$$

so that equation (C-4) becomes

$$\vec{\nabla}_{\eta\phi} \cdot [\vec{H}(\vec{r}, t) \times \hat{e}_\mu(\vec{r})] + \vec{H}(\vec{r}, t) \cdot [\vec{\nabla} \times \hat{e}_\mu(\vec{r})] = J_\mu(\vec{r}, t) . \quad (C-7)$$

APPENDIX C

Therefore, on the surface S defined by $\mu = \mu_0$, equation (C-7) becomes

$$\begin{aligned} \vec{\nabla} \cdot \vec{K}(\vec{r}_S, t) &= J_\mu(\vec{r}_S, t) \\ (2) \end{aligned} \quad (C-8)$$

where

$$\begin{aligned} \vec{\nabla} \cdot \vec{K}(\vec{r}_S, t) &= \vec{\nabla}_{\eta\phi} \cdot \vec{K}(\vec{r}_S, t) + [\vec{K}(\vec{r}_S, t) \times \hat{n}(\vec{r}_S)] \cdot \\ (2) \quad &\cdot [\vec{\nabla} \times \hat{e}_\mu(\vec{r})]_{\vec{r}=\vec{r}_S}, \end{aligned} \quad (C-9)$$

since for $\mu_0 > 0$,

$$\hat{n}(\vec{r}_S) = -\hat{e}_\mu(\vec{r}_S) \quad (C-10)$$

and

$$\vec{K}(\vec{r}_S, t) \times \hat{n}(\vec{r}_S) = \vec{H}(\vec{r}_S, t) \quad (C-11)$$

If there is only one component of surface current, namely,

$$\vec{K}(\vec{r}_S, t) = K_\eta(\vec{r}_S, t) \hat{e}_\eta, \quad (C-12)$$

then

$$\begin{aligned} \vec{\nabla}_{\eta\phi} \cdot \vec{K}(\vec{r}_S, t) &= h_\mu^{-1}(\mu_0, \eta) h_\eta^{-1}(\mu_0, \eta) h_\phi^{-1}(\mu_0, \eta) \cdot \\ &\cdot \frac{\partial}{\partial \eta} [h_\phi(\mu_0, \eta) h_\mu(\mu_0, \eta) K_\eta(\vec{r}_S, t)] \end{aligned}$$

or

$$\begin{aligned} \vec{\nabla}_{\eta\phi} \cdot \vec{K}(\vec{r}_S, t) &= h_\eta^{-1}(\mu_0, \eta) h_\phi^{-1}(\mu_0, \eta) \frac{\partial}{\partial \eta} [h_\phi(\mu_0, \eta) K_\eta(\vec{r}_S, t)] \\ &+ h_\mu^{-1}(\mu_0, \eta) h_\eta^{-1}(\mu_0, \eta) K_\eta(\vec{r}_S, t) \frac{\partial}{\partial \eta} h_\mu(\mu_0, \eta) \quad (C-13) \end{aligned}$$

Finally, since

$$\begin{aligned}
 & [\vec{K}(\vec{r}_S, t) \times \hat{n}(\vec{r}_S)] \cdot [\vec{\nabla} \times \hat{e}_\mu(\vec{r})]_{\vec{r}=\vec{r}_S} \\
 &= [K_\eta(\vec{r}_S, t) \hat{e}_\phi(\vec{r}_S)] \cdot \left[-\hat{e}_\phi(\vec{r}_S) h_\mu^{-1}(\mu_0, \eta) h_\eta^{-1}(\mu_0, \eta) \cdot \frac{\partial}{\partial \eta} h_\mu(\mu_0, \eta) \right], \quad (C-14)
 \end{aligned}$$

the differential equation for surface current is given by

$$h_\eta^{-1}(\mu_0, \eta) h_\phi^{-1}(\mu_0, \eta) \frac{\partial}{\partial \eta} [h_\phi(\mu_0, \eta) K_\eta(\vec{r}_S, t)] = J_\mu(\vec{r}_S, t) . \quad (C-15)$$

APPENDIX D. TOTAL CHARGE ON THE SPHERE

For the total charge on the sphere, Q_{sphere} , the following surface integration must be carried out:

$$Q_{\text{sphere}}(t) = \int_0^\pi \int_0^{2\pi} \rho_s(\eta, t) h_\eta(\mu_0, \eta) h_\phi(\mu_0, \eta) d\eta d\phi, \quad (\text{D-1})$$

where the surface charge density, ρ_s , is defined in equation (58) in the body of the report. Consequently, the total charge can be expressed as

$$\begin{aligned} (2\pi\epsilon_0 a)^{-1} Q_{\text{sphere}}(t) &= [-E_0(t)a \cosh \mu_0 + V(t) \sinh \mu_0/2] F_1(\mu_0) \\ &+ [(3/2)E_0(t)a \sinh^2 \mu_0] F_2(\mu_0) \\ &+ \sum_{n=0}^{\infty} V_n(t) (n + \frac{1}{2}) \cosh [(n + \frac{1}{2})\mu_0] G_n(\mu_0), \quad (\text{D-2}) \end{aligned}$$

wherein

$$F_1(\mu_0) = \int_0^\pi (\cosh \mu_0 - \cos \eta)^{-2} \sin \eta d\eta = 2(\sinh \mu_0)^{-2}, \quad (\text{D-3})$$

$$F_2(\mu_0) = \int_0^\pi (\cosh \mu_0 - \cos \eta)^{-3} \sin \eta d\eta = 2 \cosh \mu_0 (\sinh \mu_0)^{-4}, \quad (\text{D-4})$$

and

$$\begin{aligned} G_n(\mu_0) &= \int_0^\pi P_n(\cos \eta) (\cosh \mu_0 - \cos \eta)^{-\frac{1}{2}} \sin \eta d\eta \\ &= \sqrt{2} (n + \frac{1}{2})^{-1} \exp[-(n + \frac{1}{2})\mu_0]. \quad (\text{D-5}) \end{aligned}$$

Some mathematical manipulation is now necessary to simplify equation (D-2). First, S is defined as

$$S(t) = \sum_{n=0}^{\infty} V_n(t) (n + \frac{1}{2}) \cosh [(n + \frac{1}{2})\mu_0] G_n(\mu_0), \quad (\text{D-6})$$

APPENDIX D

and then S_1 and S_2 are defined as

$$S_1(t) = 2E_0(t)a \sum_{n=0}^{\infty} (2n+1) \{ \exp[-(2n+1)\mu_0] + 1 \} / \{ \exp[2n+1)\mu_0] - 1 \} \quad (D-7)$$

with

$$S_2(t) = 2V(t) \sum_{n=0}^{\infty} \{ \exp[-(2n+1)\mu_0] + 1 \} / \{ \exp[(2n+1)\mu_0] - 1 \} \quad (D-8)$$

so that

$$S(t) = S_1(t) + S_2(t) . \quad (D-9)$$

Next, use of an identity (along with its first derivative),

$$\sum_{n=0}^{\infty} \exp[-(2n+1)\mu_0] = (2 \sinh \mu_0)^{-1} , \quad (D-10)$$

leads to

$$S_1(t) = -E_0(t)a \cosh \mu_0 (\sinh \mu_0)^{-2} + 4 E_0(t)a \sum_{n=0}^{\infty} (2n+1) / \{ \exp[(2n+1)\mu_0] - 1 \} \quad (D-11)$$

and

$$S_2(t) = -V(t) (\sinh \mu_0)^{-1} + 4 V(t) \sum_{n=0}^{\infty} \{ \exp[(2n+1)\mu_0] - 1 \}^{-1} \quad (D-12)$$

The total charge on the sphere becomes, therefore,

$$(2\pi\epsilon_0 a)^{-1} Q_{\text{sphere}}(t) = E_0(t) a \cosh \mu_0 (\sinh \mu_0)^{-2} \\ + V(t) (\sinh \mu_0)^{-1} + S(t)$$

or

$$Q_{\text{sphere}}(t) = 8\pi\epsilon_0 a^2 E_0(t) \sum_{n=0}^{\infty} (2n+1) / \{\exp[(2n+1)\mu_0] - 1\} \\ + 8\pi\epsilon_0 a V(t) \sum_{n=0}^{\infty} \{\exp[(2n+1)\mu_0] - 1\}^{-1} . \quad (\text{D-13})$$

APPENDIX E. TOTAL CHARGE ON A SEGMENT OF THE SPHERE'S SURFACE

The charge defined in equation (65) in the body of the report becomes

$$\begin{aligned}
 (2\pi\epsilon_0 a)^{-1} Q(\eta, t) &= [-E_0(t)a \cosh \mu_0 + V(t) \sinh \mu_0/2] f_1(\eta) \\
 &+ [(3/2)E_0(t)a \sinh^2 \mu_0] f_2(\eta) \\
 &+ \sum_{n=0}^{\infty} V_n(t) (n + \frac{1}{2}) \cosh [(n + \frac{1}{2})\mu_0] g_n(\eta) , \quad (E-1)
 \end{aligned}$$

where

$$f_1(\eta) = (1 - \cos \eta) [(\cosh \mu_0 - 1) (\cosh \mu_0 - \cosh \eta)]^{-1} , \quad (E-2)$$

$$f_2(\eta) = (\frac{1}{2}) [(\cosh \mu_0 - 1)^{-2} - (\cosh \mu_0 - \cos \eta)^{-2}] , \quad (E-3)$$

and

$$g_n(\eta) = \int_{\cos \eta}^1 P_n(u) (\cosh \mu_0 - u)^{-\frac{1}{2}} du . \quad (E-4)$$

The function g_n can be expressed as an infinite series:

$$g_n(\eta) = \sqrt{2} \sum_{m=0}^{\infty} \exp[-(m + \frac{1}{2})\mu_0] h_{mn}(\cos \eta) , \quad (E-5)$$

where

$$h_{mn}(\cos \eta) = \int_{\cos \eta}^1 P_m(u) P_n(u) du . \quad (E-6)$$

When m and n are different integers, equation (E-6) reduces to¹

$$h_{m \neq n}(\cos \eta) = \frac{\sin \eta}{(m-n)(m+n+1)} \left[P_m(\cos \eta) \frac{d}{d\eta} P_n(\cos \eta) - P_n(\cos \eta) \frac{d}{d\eta} P_m(\cos \eta) \right]. \quad (E-7)$$

When $m = n > 0$, equation (E-6) has been cast into the form of a recursion relationship:²

$$h_{nn}(\cos \eta) = (2n+1)^{-1} \{ (2n-1)h_{n-1,n-1}(\cos \eta) - \cos \eta [(P_{n-1}(\cos \eta))^2 + (P_n(\cos \eta))^2] + 2P_{n-1}(\cos \eta)P_n(\cos \eta) \}, \quad (E-8)$$

which can be implemented for any positive integer starting with

$$h_{00}(\cos \eta) = 1 - \cos \eta. \quad (E-9)$$

¹W. Magnus, F. Oberhettinger, and R. P. Soni, *Formulas and Theorems for the Special Functions of Mathematical Physics*, Springer-Verlag, New York (1966), 191.

²S. Chang and T. B. A. Senior, *Scattering by a Spherical Shell with a Circular Aperture*, The University of Michigan, Scientific Report No. 5 (AFCRL-69-0203) (April 1969), 102.