

# Electromagnetic Scattering by Thin Inhomogeneous Circular Cylinders<sup>1</sup>

Clayborne D. Taylor

Sandia Laboratory, Albuquerque, N. Mex. 87115, U.S.A.

(Received December 8, 1966; revised January 30, 1967)

The general problem of electromagnetic wave scattering by thin inhomogeneous circular cylinders is completely formulated. An integral equation for the induced axial current distribution is derived and solved for an incident plane wave of arbitrary direction of propagation. A knowledge of this induced current allows the determination of the scattered fields as well as the scattering cross section.

For convenience the conductivity is only considered to vary axially. Numerical results are presented for the induced axial current and scattering cross section. An important application of this work is in missile vulnerability studies. To this end numerical results are presented for a missile having an ionized exhaust trail. The conductivity of the exhaust trail is considered to taper exponentially along its axis.

## 1. Introduction

The general problem of electromagnetic wave scattering from an inhomogeneous circular cylinder is solved for an electrically thin cylinder, i.e.,  $k_0 a \ll 1$ , where  $a$  is the cylinder radius and  $k_0$  is the propagation constant of the incident radiation. In this formulation the cylinder is considered to have only axial variations in its constitutive properties. Also it is assumed that an internal impedance per unit length may be defined for the cylinder. However, outside of these restrictions, the formulation is completely general.

By deriving and solving an integral equation, an expression is obtained for the current distribution induced on an inhomogeneous cylinder immersed in a general electromagnetic field. The inhomogeneous scatterer is represented by a circular cylinder with an internal impedance per unit length having an axial variation. This representation is also used by Wu and King (1965) in a very specialized theory treating a transmitting antenna with a particular axial variation of the internal impedance. The solution presented here, which is quite general, requires that the current distribution be represented by a finite Fourier series; the expansion coefficients are obtained by forcing the series representation to satisfy the original integral equation. A proposed method for aiding the convergence is also presented. An accurate solution for the induced current distribution that is analytically tractable may be used to obtain the scattered fields as well as the back-scattering cross section.

In the present day missile studies it is necessary to know accurately the electromagnetic wave scattering characteristics of finite-length cylinders. When the missile ionized exhaust plume is present, a knowledge of the scattering characteristics of inhomogeneous cylinders is needed. Typical parameters for a missile-plume study are used to obtain numerical results. The incident field is considered to be a plane wave with an arbitrary direction of propagation.

## 2. Analysis

### 2.1. Integral Equation for the Current Distribution

Consider a cylindrical structure of length  $2h$  extending from  $z = -h$  to  $z = h$  (see fig. 1). Provided that the cylinder is electrically thin, the illumination may be considered to be rotationally

<sup>1</sup> The research reported here was supported by USAF contract AFSWC Order (29-601)-64-4457.

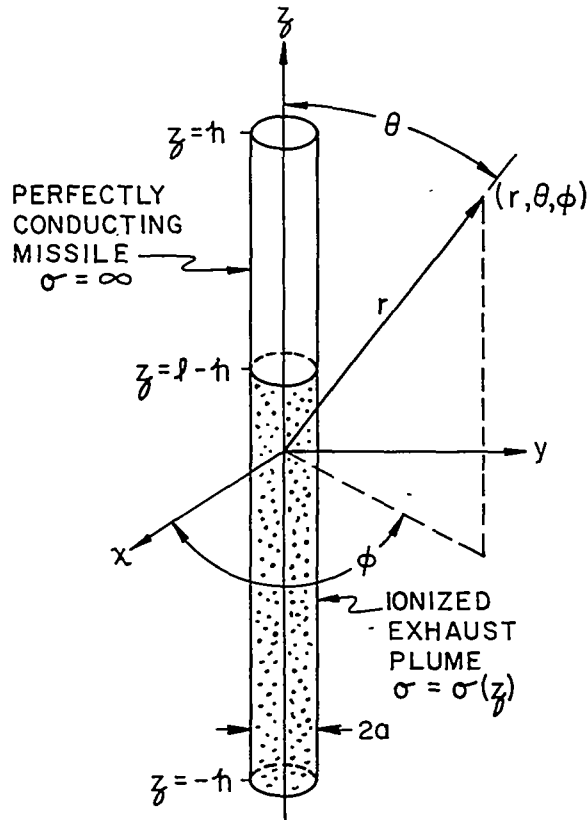

FIGURE 1. Missile with its ionized exhaust plume represented by an inhomogeneous circular cylinder of length  $l$ .

symmetric about its surface. It is easily shown that the scattered vector potential  $A_z^s(a, z)$  at the surface of the cylinder satisfies the differential equation

$$\left(\frac{\partial^2}{\partial z^2} + k_0^2\right) A_z^s(a, z) = j \frac{k_0^2}{\omega} [E_z^t(a, z) - E_z^i(a, z)], \quad (1)$$

where the assumed (but suppressed) time dependence is  $\exp(j\omega t)$ ;  $E_z^t(a, z)$  is the total electric field at point  $z$ ; and  $E_z^i(a, z)$  is the incident field at point  $z$ . It should be pointed out that (1) requires

$$\text{grad div } \vec{A}^s(r, z) \approx \hat{z} \frac{\partial^2}{\partial z^2} A_z^s(r, z), \quad (2)$$

where  $\hat{z}$  is the unit vector in the  $z$  direction.

If it is assumed that an internal impedance per unit length,  $z^i(z)$ , may be defined for the cylindrical structure of varying conductivity, then it is correct to write as the defining equation for  $z^i(z)$ ,

$$E_z^t(a, z) = z^i(z) I_z(z), \quad (3)$$

where  $I_z(z)$  is the total axial current at point  $z$ . Of course, (3) requires that rotational symmetry obtains. Combining (1) and (3), defining  $E_z^i(z) = E_z^i(a, z)$ ,

$$\left(\frac{\partial^2}{\partial z^2} + k_0^2\right) A_z^s(a, z) - j \frac{k_0^2}{\omega} z^i(z) I_z(z) = -j \frac{k_0^2}{\omega} E_z^i(z). \quad (4)$$

For an electrically thin cylinder

$$A_z^s(a, z) = \frac{\mu_0}{4\pi} \int_{-h}^h dz' I_z(z') K(z, z'), \tag{5}$$

where 
$$K(z, z') = \exp [-jk_0 \sqrt{(z-z')^2 + a^2}] / \sqrt{(z-z')^2 + a^2}. \tag{6}$$

Using (5) in (4) yields the integral equation for the current distribution

$$\int_{-h}^h dz' I_z(z') \hat{K}(z, z') - j \frac{4\pi k_0}{\zeta_0} z^i(z) I_z(z) = -j \frac{4\pi k_0}{\zeta_0} E_z^i(z), \tag{7}$$

where  $\zeta_0$  is the characteristic impedance of free space and

$$\hat{K}(z, z') = \left( \frac{\partial^2}{\partial z^2} + k_0^2 \right) K(z, z'). \tag{8}$$

Since  $k_0 a \ll 1$ ,  $\hat{K}(z, z')$  is a highly peaked function about  $z - z' = 0$  [even more so than  $K(z, z')$ ].

### 2.2. Solution for the Current Distribution

It is observed that the kernel is an even function of  $(z - z')$  and therefore may be represented

$$\hat{K}(z, z') = k_0^3 \sum_{n=0}^{\infty} A_n \cos \frac{n\pi}{2h} (z - z') \tag{9}$$

where

$$A_n = \frac{k_0^{-2} K'(h, -h)}{k_0 h \epsilon_n} (-1)^n + \frac{1 - \left( \frac{n\pi}{2k_0 h} \right)^2}{k_0 h \epsilon_n} \int_0^{2h} d(z - z') K(z, z') \cos \frac{n\pi}{2h} (z - z'), \tag{10}$$

(1)

$$\left. \begin{aligned} k_0^{-2} K'(h, -h) &= -\frac{(1 + jk_0 R_h)}{(k_0 R_h)^3} (2k_0 h) e^{-jk_0 R_h} \\ R_h &= \sqrt{4h^2 + a^2} \\ \epsilon_n &= 2 \quad n = 0 \\ &= 1 \quad n \geq 1 \end{aligned} \right\} \tag{11}$$

ic field  
uires

(2)

A general representation for the current distribution that satisfies the boundary conditions  $I_z(h) = I_z(-h) = 0$  is

$$I_z(z) = -j \frac{4\pi U}{\zeta_0} \sum_{m=0}^{\infty} \left[ I_m^s \cos \frac{2m+1}{2} \frac{\pi}{h} z + I_m^a \sin \frac{m\pi}{h} z \right]. \tag{12}$$

(3)

The constant  $U$  (in volts) will be chosen later to simplify the mathematics.

mmetry

(4)

Since 
$$\cos \frac{n\pi}{2h} (z - z') = \cos \frac{n\pi}{2h} z \cos \frac{n\pi z'}{2h} + \sin \frac{n\pi}{2h} z \sin \frac{n\pi}{2h} z', \tag{13}$$

then

$$\begin{aligned}
 & j \frac{\zeta_0}{4\pi U} \int_{-h}^h dz' I_z(z') \hat{K}(z, z') \\
 &= k_0^3 h \sum_{\substack{n=0 \\ m=0}}^{\infty} \left\{ A_n I_m^s \cos \frac{n\pi}{2h} z \int_{-h}^h dz' \cos \frac{n\pi}{2h} z' \cos \frac{2m+1}{2} \frac{\pi}{h} z' \right. \\
 &\quad \left. + A_n I_m^a \sin \frac{n\pi}{2h} z \int_{-h}^h dz' \sin \frac{n\pi}{2h} z' \sin \frac{m\pi}{h} z' \right\}. \quad (14)
 \end{aligned}$$

It is convenient to break up the sum over  $n$  to a sum over odd  $n$  plus a sum over even  $n$ ;

$$\begin{aligned}
 & j \frac{\zeta_0}{4\pi U} \int_{-h}^h dz' I_z(z') \hat{K}(z, z') \\
 &= k_0^3 h \sum_{\substack{n=0 \\ m=0}}^{\infty} \left\{ A_{2n} \left[ I_m^s \gamma_{nm}^s \cos \frac{n\pi}{h} z + I_m^a \delta_{nm} \sin \frac{n\pi}{h} z \right] \right. \\
 &\quad \left. + A_{2n+1} \left[ I_m^s \delta_{nm} \cos \frac{2n+1}{2} \frac{\pi}{h} z + I_m^a \gamma_{nm}^a \sin \frac{2n+1}{2} \frac{\pi}{h} z \right] \right\}, \quad (15)
 \end{aligned}$$

where

$$\gamma_{nm}^s = \frac{4(2m+1)(-1)^{m+n}}{\pi[(2m+1)^2 - 4n^2]}, \quad (16)$$

$$\gamma_{nm}^a = \frac{8m(-1)^{m+n}}{\pi[(2n+1)^2 - 4m^2]}, \quad (17)$$

$$\delta_{nm} = \begin{cases} 0 & n \neq m \\ 1 & n = m \end{cases}. \quad (18)$$

It is also convenient to express  $z^i(z)$  as a sum of odd and even functions, i.e.,

$$z^i(z) = z_e^i(z) + z_o^i(z), \quad (19)$$

where

$$z_e^i(z) = [z^i(z) + z^i(-z)]/2, \quad (20)$$

$$z_o^i(z) = [z^i(z) - z^i(-z)]/2. \quad (21)$$

Substituting (15) into (7), multiplying the result by  $\cos \frac{p\pi}{h} z$ , and integrating over  $z$  yields

$$\sum_{m=0}^{\infty} \{ [(k_0 h)^2 (\epsilon_p A_{2p} + A_{2m+1}) \gamma_{pm}^s + \alpha_{pm}^s I_m^s + \beta_{pm}^s I_m^a] \} = S_p^s, \quad (22)$$

where

$$\alpha_{pm}^s = -j \frac{4\pi}{\zeta_0} \int_{-h}^h z_e^i(z) \cos \frac{2m+1}{2} \frac{\pi}{h} z \cos \frac{p\pi}{h} z dz, \quad (23)$$

$$\beta_{pm}^s = -j \frac{4\pi}{\zeta_0} \int_{-h}^h z_0^i(z) \sin \frac{m\pi}{h} z \cos \frac{p\pi}{h} z dz, \tag{24}$$

$$S_p^s = \frac{1}{U} \int_{-h}^h E_{ze}^i(z) \cos \frac{p\pi}{h} z dz, \tag{25}$$

$$E_{ze}^i(z) = [E_z^i(z) + E_z^i(-z)]/2. \tag{26}$$

(14)

Also, using  $\sin(2p+1/2)(\pi/2)z$  instead of  $(p\pi/h)z$  in the foregoing procedure yields

$$\sum_{m=0}^{\infty} \{[(k_0 h)^2(\epsilon_m A_{2m} + A_{2p+1})\gamma_{pm}^a + \beta_{pm}^a]I_m^a + \alpha_{pm}^a I_m^s\} = S_p^a, \tag{27}$$

where

$$\alpha_{pm}^a = -j \frac{4\pi}{\zeta_0} \int_{-h}^h z_0^i(z) \cos \frac{2m+1}{2} \frac{\pi}{h} z \sin \frac{2p+1}{2} \frac{\pi}{h} z dz, \tag{28}$$

$$\beta_{pm}^a = -j \frac{4\pi}{\zeta_0} \int_{-h}^h z_0^i(z) \sin \frac{m\pi}{h} z \sin \frac{2p+1}{2} \frac{\pi}{h} z dz, \tag{29}$$

(15)

$$S_p^a = \frac{1}{U} \int_{-h}^h E_{z0}^i(z) \sin \frac{2p+1}{2} \frac{\pi}{h} z dz, \tag{30}$$

$$E_{z0}^i(z) = [E_z^i(z) - E_z^i(-z)]/2. \tag{31}$$

(16)

The foregoing equations show that the symmetric and asymmetric components of the current are coupled, and that this coupling is due to the asymmetry of the internal impedance of the structure.

(17)

Because the current distribution is expected to be an extremely well behaved function, the infinite series expansion given by (12) may be truncated at some high order  $N$ , where  $N^2 \gg \left(\frac{k_0 h}{\pi}\right)^2$ , and yet maintain reasonable accuracy. The effect of this truncation is the truncation of the series in (22) and (27) at order  $N$  (Duncan and Hinchey, 1960).

(18)

Although the series given by (12) is expected to be reasonably convergent for  $k_0 h < 10$  and for fairly smooth conductivity variations, the convergence may be improved by use of a good approximation to  $I_z(z)$ . Instead of using (12), one might use

(19)

$$I_z(z) = f(z) - j \frac{4\pi U}{\zeta_0} \sum_{m=0}^{\infty} \left[ I_m^s \cos \frac{2m+1}{2} \frac{\pi}{h} z + I_m^a \sin \frac{m\pi}{h} z \right], \tag{32}$$

(20)

(21)

where  $f(z) = I_z(z)$ . As yet no candidates for  $f(z)$  exist; however, an investigation is being conducted.

Consider that the cylindrical structure is irradiated by a plane wave where  $k_0 a \ll 1$ . The  $z$  component of the incident electric field may be represented in the general form

(22)

$$E_z^i(z) = E_0 \sin \psi \sin \theta \exp[-jk_0 z \cos \theta], \tag{33}$$

where the direction of propagation is at an angle  $\theta$  with the positive  $z$  axis, and the electric field is directed at an angle  $\psi$  with the normal to the plane determined by the  $z$  axis and direction of

(23)

propagation. Therefore,

$$\left. \begin{aligned} E_{ze}^i(z) &= E_0 \sin \psi \sin \theta \cos [k_0 z \cos \theta] \\ E_{zo}^i(z) &= -jE_0 \sin \psi \sin \theta \sin [k_0 z \cos \theta] \end{aligned} \right\} \quad (34)$$

Then from (25)

$$S_p^s = \frac{2 \sin(k_0 h \cos \theta) (-1)^p}{1 - (p\pi/k_0 h \cos \theta)^2 \cos \theta} \quad (35)$$

but if  $\theta = \pi/2$ ,

$$S_p^s = 2k_0 h \delta_{p0}, \quad (36)$$

or if  $k_0 h \cos \theta = \ell\pi$ , where  $\ell$  is an integer, then

$$S_p^s = k_0 h \delta_{\ell p}, \quad (37)$$

where the constant  $U$  is defined

$$U = \frac{1}{k_0} \sin \psi \sin \theta E_0; \quad (38)$$

and, from (30),

$$S_p^a = j \frac{2 \cos(k_0 h \cos \theta) (-1)^p}{1 - [(2p+1)\pi/2k_0 h \cos \theta]^2 \cos \theta} \quad (39)$$

but if  $\theta = \pi/2$ ,  $S_p^a = 0$ , or if  $k_0 h \cos \theta = (2\ell+1)\pi/2$ , where  $\ell$  is an integer, then

$$S_p^a = -jk_0 h \delta_{\ell p}. \quad (40)$$

### 2.3. Internal Impedance per Unit Length

For a general treatment of the internal impedance per unit length of uniform cylindrical conductors, the author defers to King (1963). However, it is necessary in this study to consider inhomogeneous conductors. For convenience, the permittivity and permeability of the conductors are considered to be uniform and are, respectively,  $\epsilon$  and  $\mu$ . The conductivity is considered to vary axially, i.e.,  $\sigma = \sigma(z)$ . A heuristic argument is now used to obtain the expression for the internal impedance per unit length.

According to King, if a cylinder that is long compared to its radius ( $2h \gg a$ ) is a sufficiently good conductor ( $\sigma/\omega\epsilon \gg 1$ ), its internal impedance may be written

$$z^i = \frac{k}{2\pi a \sigma} \frac{J_0(ka)}{J_1(ka)}, \quad (41)$$

where

$$k = (1-j) \sqrt{\frac{\omega \mu \sigma}{2}}. \quad (42)$$

Suppose now that the cylinder has an axial variation in conductivity such that

$$\sigma(z+10a) - \sigma(z) \ll \sigma(z), \quad (43)$$

or

$$\frac{d}{dz} \sigma(z) \ll \frac{1}{10a} \sigma(z), \quad (44)$$

at some point  $z$  on the structure. Under the considerations made in obtaining (41), it is seen that the internal impedance for the section between  $z$  and  $z + 10a$  is

$$z^i(z) = \frac{k(z)}{2\pi a \sigma(z)} \frac{J_0[k(z)a]}{J_1[k(z)a]} \tag{45}$$

If the conditions given by (43) and (44) hold over the whole structure, then it follows that (45) predicts the variation of the internal impedance for the cylindrical structure with an axial variation in conductivity.

### 2.4. Scattered Fields

Because of the azimuthal symmetry of the scattering, the scattered field components may be written

$$E_z^s(\rho, z) = -j \frac{\zeta_0}{4\pi k_0} \int_{-h}^h dz' I_z(z') \hat{K}_r(z, z'), \tag{46}$$

$$E_\rho^s(\rho, z) = j \frac{\zeta_0 \rho}{4\pi k_0} \int_{-h}^h dz' \frac{(1 + jk_0 R_r)}{R_r^2} K_r(z, z') \frac{\partial}{\partial z'} I_z(z'), \tag{47}$$

$$H_\phi^s(\rho, z) = \frac{\rho}{4\pi} \int_{-h}^h dz' I_z(z') \frac{(1 + jk_0 R_r)}{R_r^2} K_r(z, z'), \tag{48}$$

where  $(\rho, \phi, z)$  are the usual cylindrical coordinates and

$$K_r(z, z') = \frac{e^{-jk_0 R_r}}{R_r} \tag{49}$$

$$R_r = \sqrt{(z - z')^2 + \rho^2} \tag{50}$$

$$\hat{K}_r(z, z') = \left( \frac{\partial^2}{\partial z^2} + k_0^2 \right) K_r(z, z'). \tag{51}$$

In the far zone of the cylinder, i.e.,  $k_0 r \gg 1$ , (48) reduces to

$$H_\phi^s(r, \theta_1) \approx j \frac{k_0 \sin \theta_1}{4\pi} \frac{e^{-jk_0 r}}{r} \int_{-h}^h dz' I_z(z') e^{jk_0 \cos \theta_1 z'}. \tag{52}$$

Here,  $r$  and  $\theta_1$  represent the radial distance and the polar angle, respectively, specifying the field point. Using (12) in (52) yields

$$H_\phi^s(r, \theta_1) \approx \frac{e^{-jk_0 r}}{r} \left\{ \frac{k_0 h U \sin \theta_1}{\zeta_0} \sum_{m=0}^{\infty} [I_m^s A_m^s(\theta_1) + I_m^a A_m^a(\theta_1)] \right\}, \tag{53}$$

where, in general

$$A_m^s(\theta_1) = \frac{4(2m+1)\pi \cos(k_0 h \cos \theta_1) (-1)^{m+1}}{4(k_0 h)^2 \cos^2 \theta_1 - (2m+1)^2 \pi^2}, \tag{54}$$

$$A_m^a(\theta_1) = j \frac{2m\pi \sin(k_0 h \cos \theta_1) (-1)^m}{(k_0 h)^2 \cos^2 \theta_1 - m^2 \pi^2}, \tag{55}$$

but if  $k_0 h \cos \theta_1 = (2\ell + 1)\pi/2$  for some integer  $\ell$ , then

$$A_m^s(\theta_1) = \delta_{\ell m}, \quad (56)$$

or if  $k_0 h \cos \theta_1 = \ell\pi$ , then

$$A_m^a(\theta_1) = j\delta_{\ell m}. \quad (57)$$

Of course, the electric field component in the far field is simply

$$E_\theta^s(r, \theta_1) \approx \zeta_0 H_\theta^s(r, \theta_1). \quad (58)$$

It is also of interest to obtain the radar or backscattering cross section of the cylindrical scatterer. According to King (1956), it is

$$\sigma_{sc} = 4\pi r^2 \left| \frac{E_\theta^s(r, \theta)}{E^i(a, z)} \right|^2 \sin^2 \psi, \quad (59)$$

provided the scatterer is in the far zone of the observer.<sup>2</sup> If  $|E^i(a, z)|^2$  is taken as  $E_0^2$  and  $E_\theta^s(r, \theta)$  as given by (58), then (59) expresses the conventional backscattered cross section where the backscatter polarization is taken to be in the same direction as the incident. Therefore,

$$\sigma_{sc} = 4\pi(k_0 h)^2 k_0^{-2} \sin^4 \theta \sin^4 \psi \left| \sum_{m=0}^{\infty} [I_m^s A_m^s(\theta) + I_m^a A_m^a(\theta)] \right|^2. \quad (60)$$

Note that  $\sigma_{sc} = 0$  for  $\theta = 0$  or  $\psi = 0$ . This occurs because the cylindrical scatterer is considered to be electrically thin.

## 2.5. Numerical Results

As stated earlier, the infinite series expansion for the unknown current distribution may be truncated at order  $N$ . Figure 2 shows the variation in the obtained center current,  $I_z(0)$ , on a perfectly conducting cylinder for various values of  $N$ . Harrison (1966) has been able to effect an accurate solution for the current induced on a perfectly conducting cylinder. He uses an iterative solution technique iterating over 100 times when necessary to obtain highly accurate results. To make a comparison, his result for the center current is also given in figure 2. Inspection of this figure shows that when  $N = 30$ , acceptable accuracy is obtained. Therefore,  $N$  is taken to be 30 to generate the data which will be presented subsequently.

In order again to verify the solution technique, a uniformly conducting rod was treated. The results are presented in figure 3 and compared with the results of Taylor, Harrison, and Aronson (1967). Good agreement is shown; furthermore, this curve shows that the simple shifted-cosine trial function used in variational solutions of resistive antennas is not correct for this example. This phenomenon is discussed in detail by Taylor, Harrison, and Aronson.

An important application of the electromagnetic scattering from an inhomogeneous cylinder is in missile vulnerability studies. Figures 4 through 7 represent typical cases of interest in these studies. The scatterer is shown in figure 1. For convenience the ionized exhaust plume is considered to have the following exponential variation in conductivity:

$$\sigma(z) = \sigma(\ell - h) e^{-\alpha(\ell - h - z)}. \quad (61)$$

<sup>2</sup> It should be pointed out that  $\psi$  as defined here is the complement of the  $\psi$  defined by King.



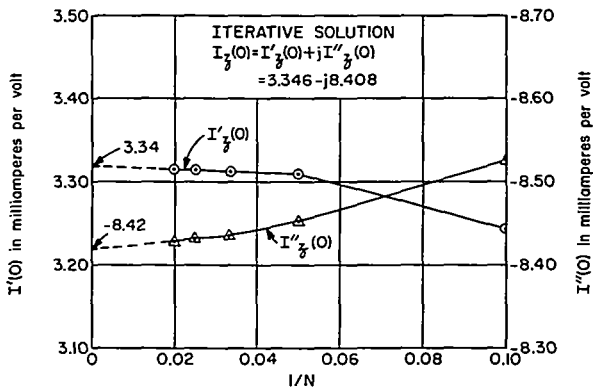

FIGURE 2. The center current on a perfectly conducting rod as a function of the number of terms used in the solution with  $k_0h = \pi$ ,  $\Omega = 2 \ell n 2h/\alpha = 10$ ,  $E_0 = k_0$  and  $\theta = \psi = \pi/2$ .

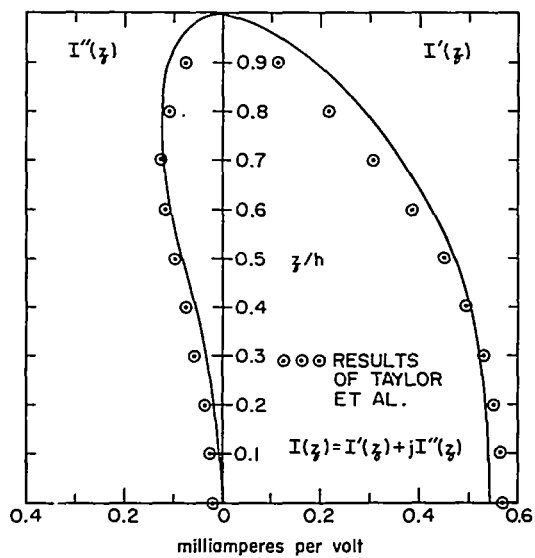

FIGURE 3. Current distribution on a uniformly conducting rod with  $k_0h = 1$ ,  $\Omega = 2 \ell n 2h/\alpha = 10$ ,  $\sigma = 0.1$  mhos/m,  $f = 5.6$  meg Hz,  $E_0 = k_0$ ,  $\theta = \psi = \pi/2$ .

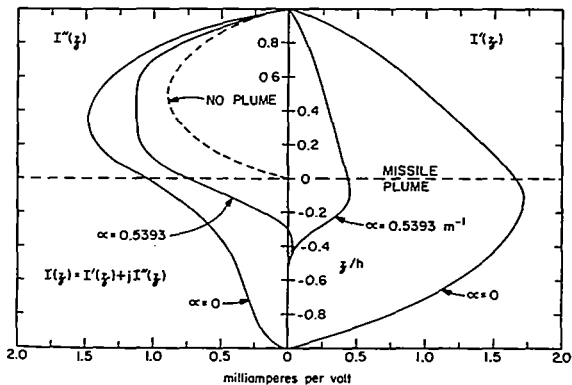

FIGURE 4. Current distributions on a missile and exhaust plume for  $k_0h = 1.0$ ,  $\Omega = 2 \ell n 2h/\alpha = 10$ ,  $\ell = h$ ,  $f = 2.8$  meg Hz,  $\theta = \psi = \pi/2$ ,  $E_0 = k_0$  and  $\sigma(\ell - h) = 0.1$  mhos/m. Note:  $I'(z) \ll 1$  mA per volt for the "no plume" case.

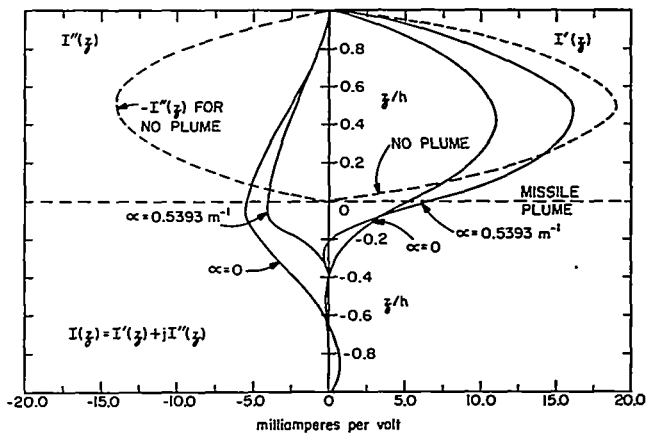

FIGURE 5. Current distributions on a missile and exhaust plume for  $k_0h = 2.6$ ,  $\Omega = 2 \ell n 2h/\alpha = 10$ ,  $\ell = h$ ,  $f = 5.4$  meg Hz,  $\theta = \psi = \pi/2$ ,  $E_0 = k_0$  and  $\sigma(\ell - h) = 0.1$  mhos/m.

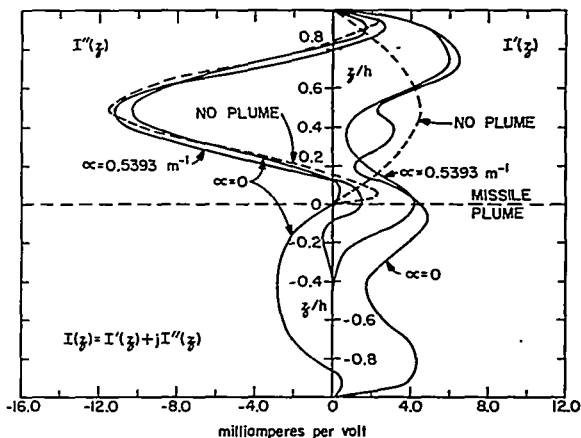

FIGURE 6. Current distributions on a missile and exhaust plume for  $k_0h = 7.0$ ,  $\Omega = 2 \ell n 2h/\alpha = 10$ ,  $\ell = h$ ,  $f = 19.6$  meg Hz,  $\theta = \psi = \pi/2$ ,  $E_0 = k_0$  and  $\sigma(\ell - h) = 0.1$  mhos/m.

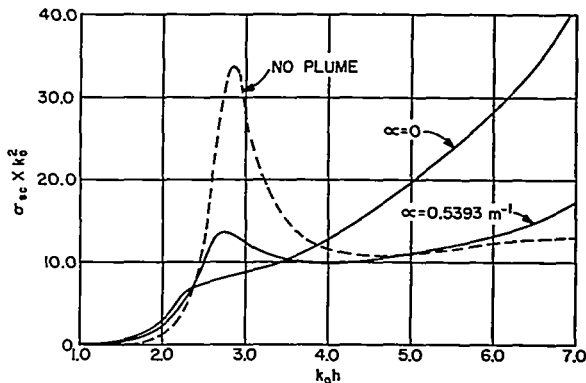

FIGURE 7. Backscattering cross section of a missile and exhaust plume as a function of electrical length,  $\Omega = 2 \ell n 2h/\alpha = 10$ ,  $\sigma(\ell - h) = 0.1$  mhos/m,  $\theta = \psi = \pi/2$ ,  $\ell = h = 17$  m.

(56)

(57)

(58)

scat-

(59)

$(r, \theta)$   
back-

(60)

dered

ay be  
a per-  
an ac-  
rative  
results.  
of this  
be 30

. The  
ronson  
-cosine  
ampl.

ylinder  
n these  
is con-

(61)

Although only a few cases are presented, some significant trends may be observed.

The electrical length of the missile in figure 4 is fairly short. The effect of the plume, even one of low conductivity, is to increase the electrical length thereby increasing the induced current on the missile. In figure 5, the missile is near a resonant length and the effect of the plume is again to increase the electric length. However, in this case the increased length is further from the resonant length, thereby decreasing the current on the missile. Note that for  $\alpha = 0.5393 m^{-1}$  the induced current in the plume essentially goes to zero near  $z = -0.4h$ . Figure 6 gives the current distribution on a relatively long structure demonstrating again the aforementioned effects.

The principal effects of the presence of an ionized exhaust plume are most clearly shown in figure 7. Here the backscattering cross section is plotted as a function of frequency. It is seen that the resonances of the missile having an ionized exhaust plume are considerably damped. Moreover, the resonant frequency is decreased by the presence of an ionized exhaust plume.

### 3. Conclusion

The general problem of electromagnetic scattering from a thin circular cylinder has been formulated so as to include cylinders of axially varying conductivity. Admittedly the methodology is approximate; however, an exact treatment of this problem is virtually impossible. The approximations made are not altogether new, but have been borne out as reasonable from previous work and experience.

A low-frequency solution to the problem of electromagnetic scattering from a missile with its plume has been obtained by Harrison, Taylor, and Ruquist (1965). Their work is accurate, but quite restricted as compared to the formulation presented here. However, the paper contains much qualitative information that could not be included in the present article.

From the numerical results of this study it is clear that the presence of the ionized exhaust plume has a surprisingly large effect upon the induced current in the missile for low-plume conductivities. Another interesting result that is obtained is the damping effect upon the resonant current buildup.

---

The author is grateful to Dr. Charles Harrison, Jr. for reading this paper and offering useful suggestions for its improvement, to Barbra Ford for typing the manuscript, and to R. E. Domres for writing the program for the digital computer.

### 4. References

- Duncan, R. H., and F. A. Hinchey (1960). Cylindrical antenna theory, J. Res. NBS **64D** (Radio Prop.), No. 5, 569-584.
- Harrison, C. W., Jr. (private communication) Sandia Corp., Albuquerque, N. Mex. 87115.
- Harrison, C. W., Jr., C. D. Taylor, and R. D. Ruquist (1965), A preliminary report on the interaction of an electromagnetic field with a missile having ionized trail, Sandia Corp. Rept. SCR-65-984, Albuquerque, N. Mex.
- King, R. W. P. (1956), The Theory of Linear Antennas, ch. IV, sec. 13 (Harvard Univ. Press, Cambridge, Mass.).
- King, R. W. P. (1963), Fundamental Electromagnetic Theory, ch. V (Dover Publications, Inc., New York, N.Y.).
- Taylor, C. D., C. W. Harrison, Jr., and E. A. Aronson (1967), Resistive receiving and scattering antenna, IEEE Trans. Ant. Prop. **AP-15**, No. 3.
- Wu, T. T., and R. W. P. King (1965), The cylindrical antenna with nonreflecting resistive loading, IEEE Trans. Ant. Prop. **AP-13**, No. 3, 369-373.