

CES DN 28

PULSED POWER TECHNOLOGY FOR CONTROLLED
THERMONUCLEAR FUSION

by

L. S. LEVINE and I. M. VITKOVITSKY

Plasma Physics Division
Naval Research Laboratory
Washington, D. C. 20390

August 1973 P

To be published in the Proceedings of the Fourth Symposium on Engineering
Problems of Fusion Research (Washington, 1971).

SUMMARY

Over the past few years, the technology of pulsed power generators has been developed to the level where it is possible to produce powers of the order of 10^{12} W for times of the order of 10^{-7} sec. Such generators are most commonly utilized to produce intense relativistic electron beams, and this paper briefly surveys the existing state of the art of generators and relativistic beams. As examples, recent work at NRL is considered in some detail. Finally, several potential applications of this technology in controlled fusion research will be discussed.

I. INTRODUCTION

Pulsed power technology, in the context of this paper, refers to the design and development of generators capable of delivering electromagnetic power at levels of the order of 10^{12} W for times of the order 10^{-7} sec or less. This technology has been largely, although not exclusively, applied to the generation of high current, pulsed, relativistic electron beams, and it is this aspect which will be emphasized in the present paper.

The entire field of pulsed power technology is less than ten years old¹, and the first paper dealing with experimental observations of intense relativistic electron beams was published in 1966². Research began at NRL a year or so later, under the leadership of A. C. Kolb, W. Lupton and D. C. dePackh. Since the field is so new, however, and since so many of the results have not yet reached the published literature, one of the goals of this paper is to briefly survey the field and provide some references to original sources where more details can be found. A second objective will be to provide an introduction to some of the research and development presently

underway at NRL, and to use that program as a focus to elucidate some of the more general comments which will follow. Finally, we discuss a subject which is of primary interest to the participants in this Conference, the possible applications of pulsed power technology and relativistic beams to controlled thermonuclear fusion. This is a field which is in its infancy, so that many of the applications are still speculative. Researchers in the pulsed power and relativistic beam field are generally quite optimistic, however, about the long range implications of the technology for CTR.

II. SURVEY OF PULSED POWER AND INTENSE RELATIVISTIC BEAMS

The range of parameters that characterize present intense relativistic electron beam generators is listed in Table 1. A few general comments can be made regarding these parameters. First, available beam energies are well within the capabilities of more traditional pulsed capacitor bank technology, although the operating voltages here are considerably higher. This implies that if, as is usual, the initial energy storage is in a capacitor bank, some mechanism such as a Marx generator or pulse transformer is required to increase the voltage at which the energy is delivered. Second, the power levels are in the 10^{11} to 10^{13} W range, considerably above the levels available directly from capacitor banks. Thus, the energy must be transferred from the original source to a "fast" section such as a charged transmission line, from which it can be delivered very rapidly to the load. To extend this point somewhat, the impedances of these generators or loads tend to be low (0.1 to 100 ohms) and, in order to deliver energy in 10^{-7} or 10^{-8} seconds,

considerable care must be devoted to minimizing all series inductances in the system, including that of the load and of switches within the system. A third observation is that the current densities within the diodes or relativistic electron beams are of the order of 10^3 to 10^5 A/cm², so the power densities are in the range of 10^8 to 10^{12} W/cm² which is more than sufficient to destroy such objects as calorimeters and probes placed in the path of the beams. Moreover, these current densities correspond to electron densities of the order of 10^{11} to 10^{13} cm⁻³, which is comparable to that of many laboratory plasmas.

The general structure of relativistic beam generators was alluded to above, and is shown schematically in Fig. 1. The initial energy storage is usually in a capacitor bank which is connected in the form of a Marx generator³. Such generators are now commercially available⁴, and have reached fairly high levels of sophistication. The Marx generator is switched to pulse charge a pulse forming line which is either in the form of a conventional transmission line, or is in a Blumlein configuration⁵, in order to double the voltage delivered at the load. The pulse forming line may be either coaxial or planar, depending in part on the geometry of the load to which the energy is to be delivered.

A successful variation of the above procedure has been employed by Ion Physics Corporation on several low energy generators⁶. By using, as the dielectric in the fast section, high pressure gas with good long-time breakdown properties, they have been able to charge the pulse forming line directly from a d.c. power supply.

The dielectric used in the pulse forming section may be any material which has a high dielectric constant for efficient energy storage, and a high dielectric strength to prevent breakdown, at least over the time scales during which high voltages appear on the pulse line. In practice, high pressure gas⁶, oil⁷, mylar⁸, and water⁹ have all been used successfully and, at NRL, we have had experience with all but the first. A detailed analysis of design considerations, such as has been presented for the NRL Gamble II generator¹⁰, shows that the time-dependent breakdown properties of the various dielectrics make water a logical choice for low impedance (below $\sim 6 \Omega$) coaxial systems, and oil, a candidate for higher impedance systems¹¹.

Switching the energy from the pulse forming line to the diode load presents considerable problems. One must typically hold off several megavolts until the command to fire is given. At the same time, the inductance of the switch must be kept sufficiently low that the inductive risetime (L/R) remains small compared to the pulse duration. These problems were to some extent avoided in the original designs of Gamble I and II by using two over-volted (i.e., self-triggered) water gaps in each generator (one is used at the input to the pulse forming line, and one at the output), and by operating the pulse line at a higher impedance than is desired at the generator output, in order to reduce the inductive risetime due to the switches. However, to preserve statistical reproducibility, these switches must each be set to fire at 80 to 90% of peak voltage, which imposes a considerable energy penalty. Therefore, both machines are being converted to command-triggered operation. In Gamble I, this has been done by using a single channel gas

switch at the input to the pulse forming line, and a multiple channel gas switch at the output. Both switches were designed and fabricated by Ion Physics Corporation¹², but only the former has been installed to date. It has been operated up to 2.8 MV with a jitter of 30 nsec. The higher voltages (6.8 MV) on the pulse forming line of Gamble II make gas switching less practical and a triggered water switch is presently being developed by Shipman for use on that machine. It is shown schematically in Fig. 2.

Generators which work at lower pulse line impedances present even more stringent inductance requirements and sophisticated multichannel, low-jitter command switching, such as was discussed at this Conference¹³, is required. Finally, at lower voltages (100's of kV), solid dielectric switching is very appealing because of the low inductances, although some inconvenience is involved in replacing the switch after each firing. Self-triggered solid switches were developed by Martin and his coworkers at AWRE¹¹ and triggered multichannel switches have been developed at NRL¹⁴. A new approach, involving laser triggering of solid switches was discussed at this Conference by the Cornell group¹⁵. This seems particularly promising when careful time correlation is required.

The energy, having been switched out of the pulse forming line, travels down to the diode region. There are really two regions of engineering interest here, the diode support structure and the field emission diode itself. The former is subject to the same two constraints encountered with switches, namely, to maintain a low inductance configuration while preventing voltage breakdown. As an example of the state of the art, the G-4 diode structure¹⁰, which is used on Gamble I and II, is shown schematically in Fig. 3. The

acrylic spacers, alternated with aluminum rings, serve to insulate the cathode region from the grounded outer tank, and guide the electromagnetic energy flow toward the diode. The interior sides of the acrylic spacers are angled to decrease the probability of voltage breakdown. The spacers also act as a mechanical interface between the water and the vacuum regions of the diode. Great care must be exercised in the design of this structure to minimize voltage flashover. For example, metallic falsework is introduced to redistribute the fields and produce a more uniform distribution of potential gradient across the insulator surfaces. A version of Boers' electrostatic field plotting code¹⁶ and an electrolytic field plotting tank were used extensively in the design work. The G-4 diode structure was designed to hold off 1.5 MV for 70 to 80 nsec and provide an effective inductance of about 30 nH.

At the currents and voltages considered here, the behavior within the field emission diode region is exceedingly complex. Although considerable research has been done, no complete or self-consistent picture of the phenomena has emerged yet^{8,9,17}. The dominant mechanism is generally agreed to be field emission, but the flow is not generally space-charge limited, particularly in low impedance diodes. This latter phenomenon is reflected in the fact that the measured impedances of such diodes tend to be considerably below the classical Child-Langmuir value for a planar diode:

$$Z = 136 \left(\frac{d}{r} \right)^2 V^{-1/2}$$

where d is the cathode-anode spacing, r is the cathode radius, and V is the voltage in megavolts. In several experiments, the scaling of impedance has been found to depend on diode geometry and voltage as predicted by Child-Langmuir theory, although the constant factor is much less than that given above¹⁷.

The reduced impedance is presumably due to the presence, within the gap, of ions or plasma which neutralize some of the space charge. The diode region is typically maintained at pressures of the order of 10^{-5} to 10^{-8} Torr and ions produced by electron collisions with the ambient gas can certainly play an important role in the diode dynamics. Moreover, other material is believed to enter the diode gap from the anode (either anode material or gas on the anode surface) and the cathode (by the explosion of whiskers or sputtering or vaporization of material from the surface)⁹. These are probably important in the later parts of the pulse. An additional complication is the presence of a "prepulse" voltage which appears across the diode preceding the main pulse. This is due to the charging voltage on the pulse forming line being capacitively coupled across the output switch. The prepulse can be an appreciable fraction of the main pulse amplitude, reaching levels of the order of hundreds of kilovolts. It is deliberately suppressed on some generators but appears to have beneficial, although not well understood, effects on other machines such as Gamble I and II. It may be related to the time for intense field emissions to start for a given type of cathode. It is clear, in any event, that the presence of large prepulse voltages on a diode can significantly alter the diode dynamics during the main pulse.

Another characteristic which distinguishes these diodes from more conventional ones is the fact that, because of the very high currents, the self magnetic fields can appreciably alter the dynamics of the electrons in the diode gap. Under typical conditions within these diodes, this can lead to intense pinching of the beam¹⁸. As an example, on Gamble II a beam of $I = 1.0$ MA ($B_{\text{self}} = 40$ kG), emitted from a ring cathode of 5.0 cm diameter, will deliver the bulk of its energy to a spot less than 2 cm in diameter at the anode, although the anode-cathode separation is only 0.7 cm. In order to

suppress this pinching, an axial magnetic field of several kilogauss is imposed on the diode region. Semiempirical relations have been derived¹⁸ which can predict the conditions under which diode pinching will occur, and the axial fields that are required to prevent it.

The presence of ions, prepulse and self magnetic field all must play some role in the observed deviation from the Child-Langmuir model. The principal source of low impedance, however, is generally felt to be the existence of a "plasma cathode". This refers to a sheath of plasma which is believed to form early in the pulse at the surface of the field emission cathode, and to provide the source of most of the electron emission during the pulse. This sheath is believed to form, no matter what type of cathode is employed (e.g. - multiple needles, ridged metal, metal plates with plastic-filled inserts, sharp edged rings or razor blades). Indirect evidence indicates that the plasma sheath expands toward the anode at velocities of 10^6 to 10^7 cm/sec thereby effecting the time dependence of the impedance¹⁹. The precise nature of the plasma cathode, and its relation to details of cathode geometry or to the other factors mentioned above are not understood at present. Semiempirical techniques, however, do generally permit adequate control over diode behavior during the duration of the pulse. As an example, Fig. 4 shows the measured current and voltage as a function of time at the diode of the Gamble II generator. Also shown are the calculated values of impedance and power as functions of time. Note that the impedance is maintained at a fairly constant value for the duration of the pulse. The cathode employed was made of a 4 cm diameter disk of aluminum coated stainless steel in which a spiral groove had been cut.

While empirical relations do exist, we are presently able to predict the diode impedance a priori, only for high impedance diodes. There, the relatively lower currents and larger gaps permit a less complex situation. Thus, Boers¹⁶

has applied classical Child-Langmuir space charge theory to the case of a cathode consisting of a stalk with a hemispherical tip and a planar anode, and good agreement was found with measured impedances.

After being generated, the beam is extracted from the diode into a drift tube by passing it through a thin anode window. To minimize electron scattering, very thin anode foils, using materials such as 1/4 mil aluminized mylar, are employed. The drift region is generally constructed of metallic cones or cylinders, or lucite tubing with metallic screening along the inner wall. Except in the presence of very strong axial magnetic guide fields, some sort of conducting return path for the beam current has been found to be necessary for efficient beam propagation. The bulk of the return current does not flow in the conducting walls but in the plasma channel produced by the beam itself. Thus it is necessary to either provide neutral gas at such a pressure that gas breakdown and a plasma return current can easily form, or a preionized medium within the drift region. The pressure range over which efficient beam propagation is observed, extends from ~ 200 mTorr to 2 Torr in neutral air.

In the absence of this plasma or counterstreaming current, magnetic self-forces would tend to pinch the beam and prevent its propagation. Indeed, early theoretical studies²⁰ indicated that there should exist a critical current above which magnetic pinching would prevent propagation, but it has been experimentally observed that "magnetic neutralization" by counterstreaming currents permit beams far in excess of the critical current to propagate.

There have been a large number of theoretical and experimental studies concerning the details of relativistic beam propagation in neutral gas²¹, in

plasma²², and in applied magnetic fields²³. It goes beyond the scope of this article to discuss them except to comment briefly on some of the more important results. Beams of total energies from 10^3 to 10^5 J have been produced, and efficient propagation of beams of the order of 10^4 J has been observed over distances of one meter in the presence of axial magnetic fields²⁴. Beam concentration has been demonstrated by the use of converging magnetic fields²⁵, and preliminary attempts have been made to combine several beams²⁶. Thus it now seems feasible to consider the availability of beams of as much as 10^5 to 10^6 J, which have power densities in excess of 10^{11} W/cm² for times of the order of 10^{-7} sec, and which can be propagated, manipulated, and combined. Some possible implications of such beams for controlled fusion will be discussed in Section IV.

III. NRL FACILITIES

The characteristics of a number of NRL generators are shown in Table 2. In addition to those listed, we should mention a 40 ohm oil Blumlein line which was used for high impedance diode studies, and several low impedance parallel plate mylar Blumlein lines²⁷ which have been used to drive theta pinch coils for collisionless shock wave studies.

The first generator listed in Table 2 is a low impedance coaxial water Blumlein line²⁸. It represents a fairly inexpensive and compact generator that is suitable for routine laboratory operation. By using a Blumlein geometry, the voltage requirements on the initial energy storage system are reduced. This, in turn, has allowed us to use a simple air-insulated "swinging-LC"²⁹ generator instead of a more cumbersome oil-filled

Marx generator.

The next generator listed is presently being designed and built at NRL³⁰ to serve as an injector for a large electron ring accelerator being constructed at the University of Maryland³¹. The generator is shown schematically in Fig. 5. It consists of a Marx generator which charges a 10 ohm coaxial water Blumlein line. The pulse from this goes into a coaxial oil transmission line which, because of a tapered inner conductor, acts as a voltage (and impedance) step-up transformer. The output of the oil line, in turn, drives a high impedance diode. The rationale behind this fairly complex design was to develop a relatively high voltage and high impedance system in which the initial energy storage and the switching could be done at the lowest possible voltages.

The last two generators listed in Table 2 are Gamble I and Gamble II. The design principles for these two generators are basically the same, and have been discussed in detail elsewhere^{9, 10}. Very briefly, they are charged coaxial water transmission lines which utilize a tapered coaxial water section as a step-down transformer between the pulse forming line and the diode load. They are both designed to produce a 1 MV potential across the appropriate diode load for a time of 50 nsec, although the operating figures shown in Table 2 are more typical of routine operation. They both utilize relatively slow Marx generators which discharge into a water transfer (or intermediate storage) capacitor. This, in turn, is switched to charge the pulse forming line, which discharges into the high impedance input of the tapered transformer section. The transformer output finally delivers the energy to the field emission diode where the beam is formed. These various

sections are shown in Fig. 6, which is a schematic of Gamble II. The electrical characteristics of the two generators are compared in more detail in Table 3.

One final aspect of the NRL work should be mentioned briefly. We have embarked on a program of computer simulation of relativistic electron beam behavior to supplement the experimental studies³². This work utilizes a very sophisticated computer code, known as CYLRAD, that can analyze the two-dimensional behavior of electrons and ions with time. It includes the effects of self-consistent fields between particles as well as applied fields, boundaries, and radiation effects. Early results are quite promising and we expect it to be a very useful adjunct to our studies.

IV. APPLICATIONS TO CONTROLLED FUSION

While the preceding sections have dealt with accomplishments and described the existing state of the art, this last section must be primarily speculative. The field of pulsed power and relativistic electron beams is, itself, very young and the application of it to controlled thermonuclear fusion is really just in its infancy. All that will be attempted here is to mention some of the more promising approaches that have been suggested.

It might be of value to start by noting some of the characteristics of these beams that make them interesting for fusion. First, as was discussed earlier, intense beams have very high power densities and quite respectable energies. Moreover, a significant fraction of that energy can be in the form of large azimuthal self-magnetic fields, which could be utilized for plasma containment. Second, as beams they can produce turbulence

in plasmas and interact with this turbulence to heat the plasma much more efficiently than by classical resistive mechanisms. Finally, because they are highly nonneutral, they can provide a deep electrostatic potential well for trapping ions.

The large power densities available have led to the suggestion³³ that relativistic electron beams be used to hit small solid pellets of a D-T mixture, much as has been considered for lasers. There are several interesting points of comparison between relativistic beams and Q-switched lasers. Lasers are capable of higher power densities because photon beams can be focussed to such small spot sizes, and because the pulse duration can be reduced to picoseconds. On the other hand, existing relativistic beams can deliver over two orders of magnitude more energy than Q-switched lasers. Further, electron beams are far more efficient in conversion of capacitor bank energy to energy delivered at a target, and beams are about one hundred times less expensive per joule of delivered energy.

Detailed calculations of the interaction between the beam and the pellet have not been published, but some collective interaction is generally assumed. Based on preliminary calculations, Winterberg³³ has estimated that an input energy of 5×10^6 J is necessary to produce an inertially confined fusion plasma. Eden and Saunders³⁴ have calculated that, even with a heavy solid tamper surrounding the D-T pellet, it would take $\sim 10^9$ J to produce any useful energy return. More recently, however Babykin, et al³⁵ have estimated that only $\sim 10^5$ J would be required in 1 nsec, if one considers tamping and the large magnetic fields associated with the beam.

No experimental data has been reported yet relevant to this approach.

A second application that has been suggested for relativistic beams is to use them to fill Astron-like machines. Here, relativistic beams are used to produce layers of rotating electrons which provide a suitable magnetic field configuration for trapping hot ions. Two, somewhat different, approaches to this problem have already been attempted. In the first³⁶, an annular electron beam was passed through a cusp magnetic field to cause it to rotate. It was then made to move in an axial mirror field with resistive rings to damp its axial motion, thus creating an Astron-like configuration. In the second approach³⁷, a small intense relativistic beam was injected nearly tangentially within a cylindrical chamber placed in an axial mirror field. The beam swept out a helical path between the mirror points of the field, thus again forming an Astron-like configuration. Using this latter technique, field reversals of 100% have been reported in a small system.

The notion of using an intense relativistic electron beam to turbulently heat a plasma is appealing in that it represents an extension of the considerable body of knowledge that has already been accumulated on beam-plasma interactions. Because the parameters of these beams are so different from those of the conventional electron beams which have been used to heat plasmas, much of the theoretical analysis of such interactions will have to be modified, but very little has been done to date. Neither have there been any experimental results reported yet of turbulent heating by relativistic beams. One interesting approach³⁸ to fusion might involve turbulently heating ions by a relativistic beam, and simultaneously using

the electrostatic potential well produced within a beam to trap the hot ions. Again, very little work has been done on this possibility.

V. SUMMARY AND ACKNOWLEDGEMENTS

The purpose of this paper was to provide a cursory introduction to the field of pulsed power technology and relativistic electron beams to engineers working in the controlled fusion program. As is evident from the text and references, this field is new and growing quite rapidly. It has reached the stage of maturity at which serious consideration is being given to its potential applicability to controlled thermonuclear fusion. Several possible ways in which it might be applied were mentioned, but they should be regarded as a framework for stimulating further thought within the CTR community, rather than as a definitive list of approaches.

It is a pleasure to acknowledge the cooperation of the members of the relativistic beam groups at NRL and Cornell University in preparing this paper. The research at NRL has been supported by the Defense Atomic Support Agency.

REFERENCES

1. J. C. Martin, private communication.
2. S. E. Graybill and S. V. Nablo, Appl. Phys. Lett. 8, 18 (1966).
3. E. Mark, Elektrotechnische Zeitschrift 45, 652 (1925); R. A. Fitch, "Marx and Marx-Like High Voltage Generators", in the Proceedings of this Conference.
4. For example, Marx generators can be purchased from Maxwell Laboratories, Inc. of San Diego, Calif., and Physics International of San Leandro, Calif.
5. A. D. Blumlein, "Electrical Network for Forming and Shaping Electrical Waves", U. S. Patent No. 2,465,840, March 29, 1949.
6. S. E. Graybill and S. V. Nablo, IEEE Trans. on Nucl. Sci. NS-14, 782 (1967); J. R. Uglum, S. E. Graybill, and S. V. Nablo, Rev. Sci. Instr. 40, 1413 (1969).
7. W. T. Link, IEEE Trans. on Nucl. Sci. NS-14, 777 (1967); T. H. Martin, IEEE Trans. on Nucl. Sci. NS-16, 59 (1969).
8. J. J. Clark, M. Ury, M. L. Andrews, D. A. Hammer, S. Linke, in the Record of the Tenth Symposium on Electron, Ion, and Laser Beam Technology, L. Marton, Ed. (San Francisco Press, San Francisco, 1969), p. 117.
9. J. Block, J. Burton, J. Frame, D. Hammer, A. C. Kolb, L. S. Levine, W. H. Lupton, W. F. Oliphant, J. D. Shipman, Jr., I. M. Vitkovitsky, "The NRL Relativistic Electron Beam Program", to be presented at the Eleventh Symposium on Electron, Ion, and Laser Beam Technology (Boulder, Colorado, May, 1971).
10. J. D. Shipman, Jr., "The Electrical Design of the NRL Gamble II Pulse Generator", in the Proceedings of this Conference; also NRL Memorandum Report 2212 (March, 1971).

11. Much of the original data concerning dielectric breakdown, as well as a variety of other information concerning the design, construction and operation of pulsed power generators, was developed by J. C. Martin and his coworkers at A.W.R.E., Aldermaston, England.
12. H. Milde, private communication.
13. D. Markins, "Low Jitter Command Trigger System for Megavolt Generators", in the Proceedings of this Conference. Multichannel switching without command triggering has also been employed. See, for example, I. M. Vitkovitsky, "Multichannel Switching for High Power Discharges", NRL Memo Report No. 1831, Oct, 1967.
14. R. W. Waynant, J. D. Shipman, Jr., R. C. Elton, and A. W. Ali, Appl. Phys. Lett. 17, 383 (1970).
15. M. Ury, D. Morse, and M. Friedman, "Laser-Triggered Solid Dielectric Switching", in the Proceedings of this Conference.
16. J. E. Boers "Digital Computer Simulation of High Current, Relativistic and Field Emission Electron Tubes", to be presented at the Eleventh Symposium on Electron, Ion, and Laser Beam Technology (Boulder, Colorado, May, 1971); J. E. Boers and D. Kelleher, J. Appl. Phys. 40, 2409 (1969).
17. J. Clark, "Operational Characteristics and Entrance Conditions of a High-Current Relativistic Electron Beam Accelerator", Ph. D. Thesis, Cornell University (Ithaca, N.Y., 1969); I. M. Vitkovitsky, in the Proceedings of the Sixth Symposium on Fusion Technology (Commission of the European Communities, Luxembourg, 1970), p. 59.
18. D. Hammer, F. Oliphant, I. Vitkovitsky, and V. Fargo, "Interaction of Accelerating High Current Electron Beams with External Magnetic Fields", submitted for publication.
19. R. K. Parker, "The Behavior of Low-Impedance Field Emission Diodes", to be presented at the Eleventh Symposium on Electron, Ion, and Laser Beam Technology (Boulder, Colorado, May, 1971).

20. H. Alfvén, Phys. Rev. 55, 425 (1939); J. D. Lawson, J. Elec. and Cont. 3, 587 (1957); J. D. Lawson, J. Elec. and Cont. 5, 146 (1958).
21. G. Yonas and P. Spence, in the Record of the Tenth Symposium on Electron, Ion, and Laser Beam Technology, L. Marton, Ed. (San Francisco Press, San Francisco, 1969), p. 144; M. L. Andrews, H. Davitian, D. A. Hammer, H. H. Fleischmann, J. A. Nation, and N. Rostoker, Appl. Phys. Lett. 16, 98 (1970).
22. D. A. Hammer and N. Rostoker, Phys. Fluids 13, 1831 (1970); L. S. Levine, I. M. Vitkovitsky, D. A. Hammer, and M. L. Andrews, J. Appl. Phys. 42, 1863 (1971).
23. M. Andrews, J. Bzura, H. Fleischmann, N. Rostoker, Phys. Fluids 13, 1322 (1970); J. Bzura and S. Linke, Bull. Amer. Phys. Soc. 15, 1452 (1970).
24. D. A. Hammer, J. L. Block, L. S. Levine, I. M. Vitkovitsky, Bull. of the Amer. Phys. Soc. 16, 595 (1971).
25. H. Davitian, J. Bzura, W. Gardner, S. Linke, I. Vitkovitsky, and L. Levine, Bull. Amer. Phys. Soc. 15, 1452 (1970).
26. J. Nation, private communication.
27. L. S. Levine, I. M. Vitkovitsky, and A. C. Kolb, in Shock Tubes: Proceedings of the Seventh International Shock Tube Symposium, I. Glass, Ed. (Univ. Toronto Press, Toronto, 1970), p. 463.
28. J. J. Condon, in the Record of the Tenth Symposium on Electron, Ion, and Laser Beam Technology, L. Marton, Ed. (San Francisco Press, San Francisco 1969), p. 131.
29. R. A. Fitch and V.T.S. Howell, Proc. IEE 111, 849 (1964).
30. J. J. Condon and W. H. Lupton, private communication.
31. M. P. Reiser, "University of Maryland ERA Concept", presented at the 1971 Particle Accelerator Conference (Chicago, March, 1971).

32. J. P. Boris and R. Lee, "Computational Studies of Relativistic Electron Beams", to be presented at the Eleventh Symposium on Electron, Ion, and Laser Beam Technology (Boulder, Colorado, May, 1971).
33. F. Winterberg, Phys. Rev. 174, 212 (1968).
34. M. J. Eden and P. A. H. Saunders, Nuclear Fusion 11, 37 (1971).
35. M. V. Babykin, E. K. Zavoiskii, A. A. Ivanov, L. I. Rudakov, "Assessment of the Use of a High-Power Beam of Relativistic Electrons for Thermonuclear Fusion", to be presented at the Fourth Conference on Plasma Physics and Controlled Nuclear Fusion Research (Madison, Wisconsin, June, 1971).
36. M. Friedman, Phys. Rev. Lett. 25, 567 (1970).
37. H. Fleischmann, Bull. Amer. Phys. Soc. 16, 97 (1971).
38. M. Friedman and N. Rostoker, private communication.

FIGURE CAPTIONS

- Figure 1. Schematic representation of a relativistic electron beam generator.
- Figure 2. Triggered water switch for the pulse forming line of Gamble II.
- Figure 3. The G-4 diode envelope employed on Gamble I and II, showing: (1) field emission cathode; (2) inner (cathode) conductor; (3) outer (ground) conductor; (4) acrylic spacer rings; (5) aluminum rings; (6) metallic falsework to guide energy flow; (7) vacuum region; (8) water region.
- Figure 4. Measured diode beam behavior on Gamble II. The cathode was 4 cm in diameter; the diode gap was 6.5 mm; the background pressure was 2×10^{-4} Torr; and the applied axial magnetic field was 8 kG. Total beam energy was 28 kJ.
- Figure 5. Schematic of ERA injector.
- Figure 6. The Gamble II generator, showing: (1) Marx generator; (2) polyurethane diaphragm separating oil and water sections; (3) water transfer capacitor; (4) pulse forming line; (5) tapered transformer section; (6) field emission diode.
- Table 1. Parameters of intense relativistic electron beams.
- Table 2. NRL relativistic electron beam generators.
- Table 3. Electrical parameters of the Gamble generators.

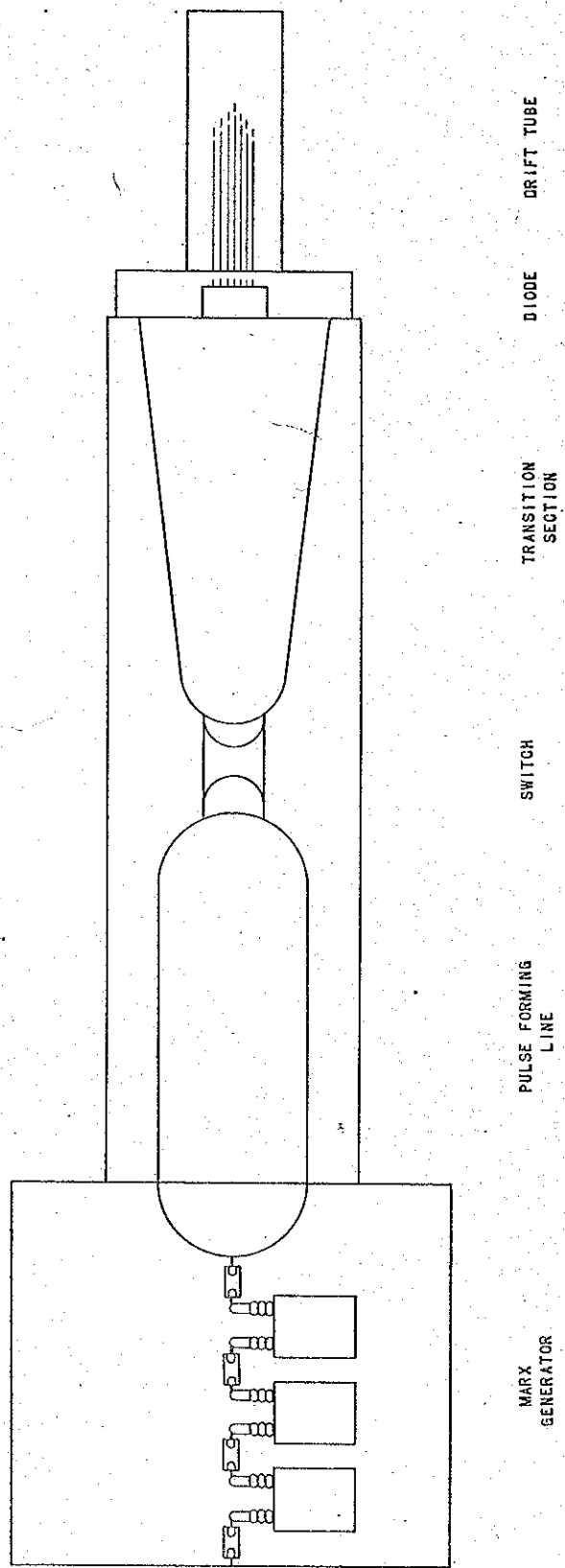

Figure 1.

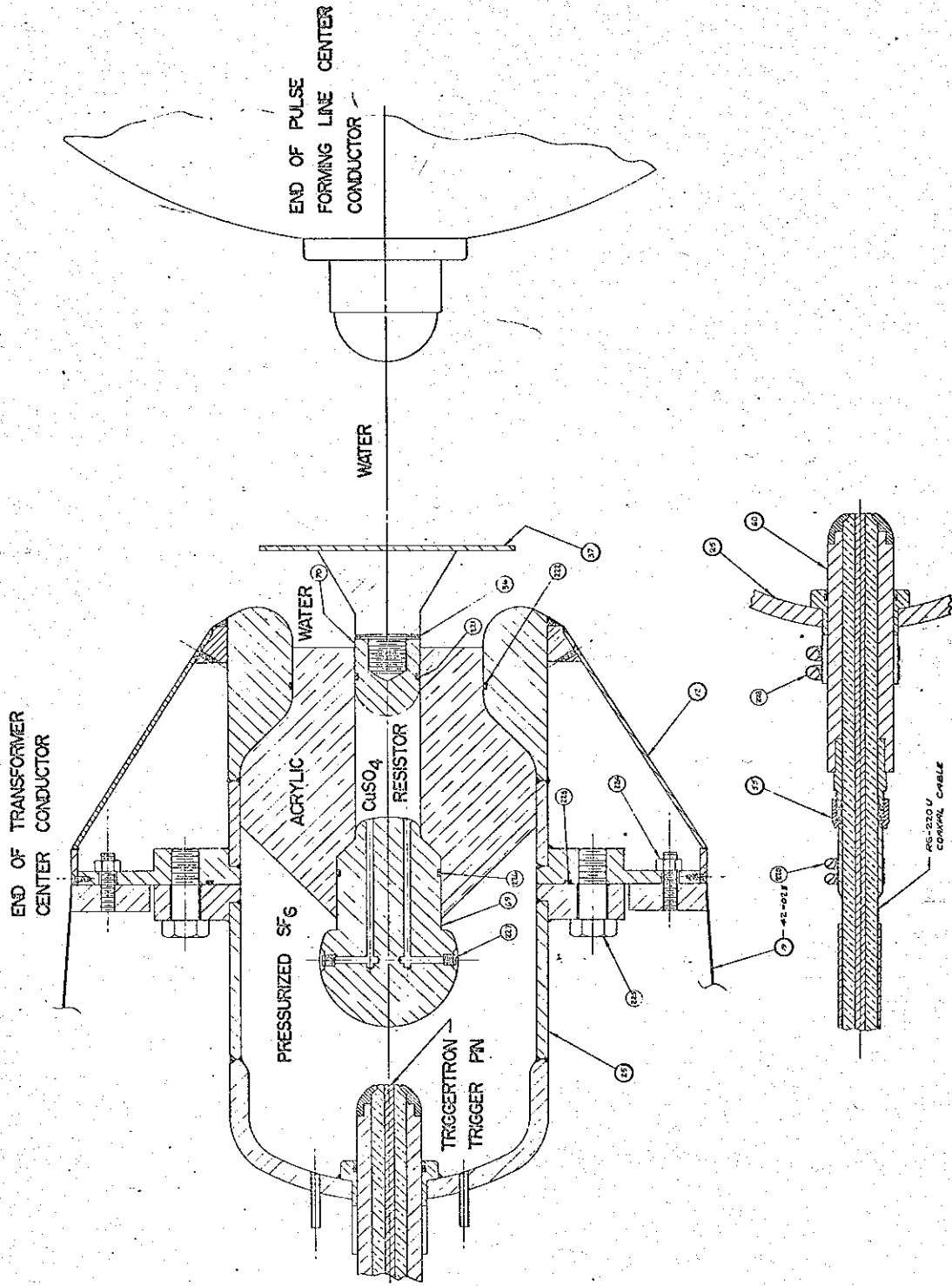

Figure 2.

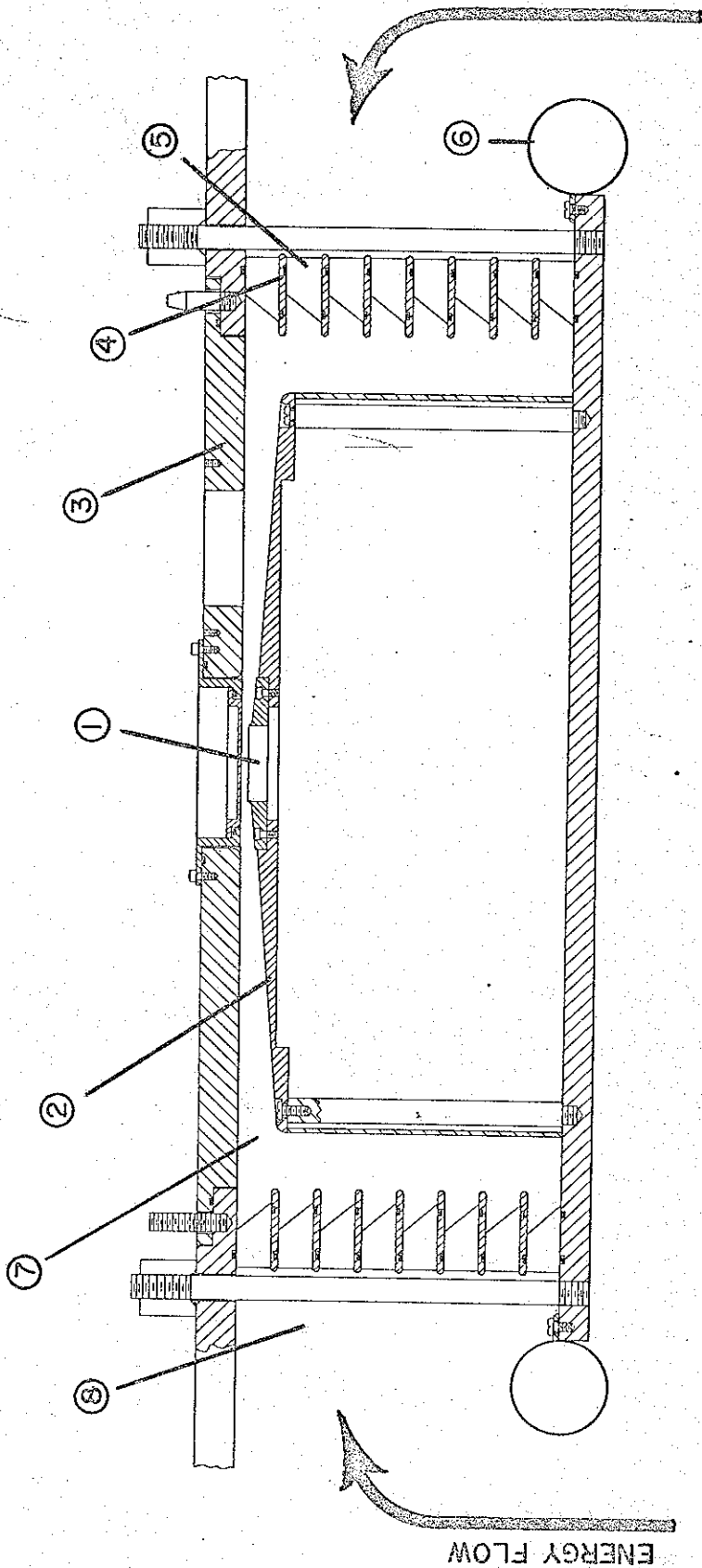

Figure 3.

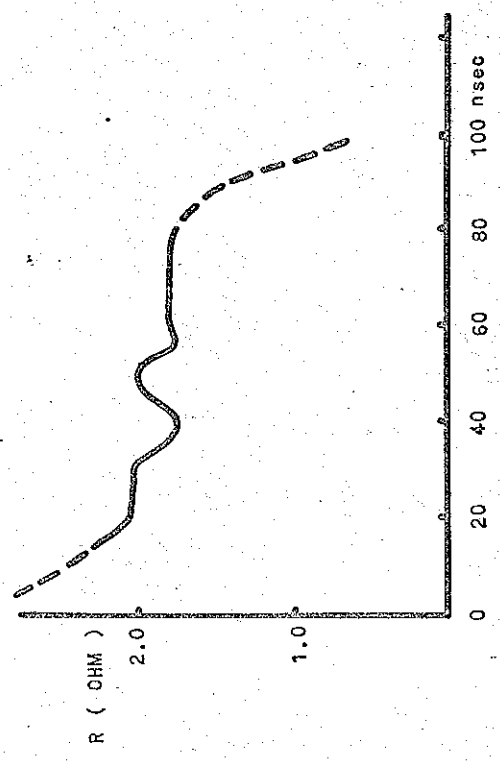
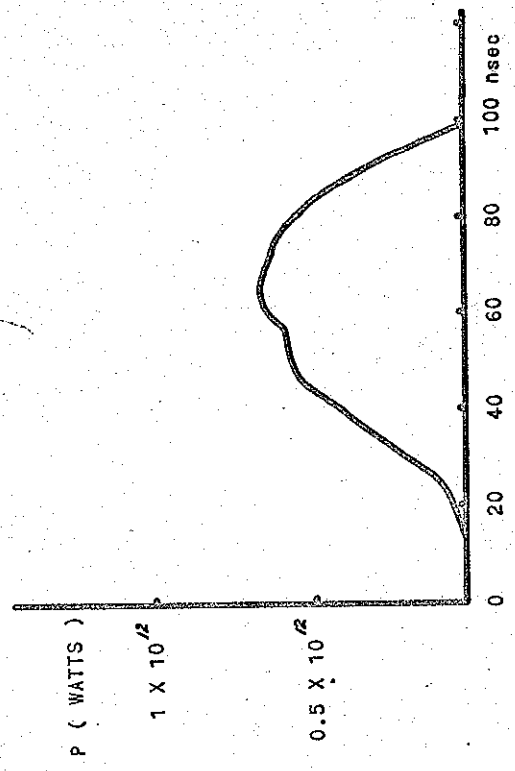
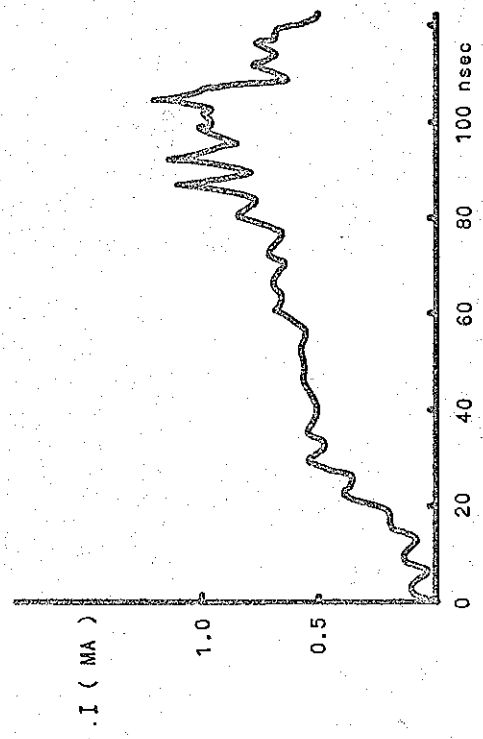
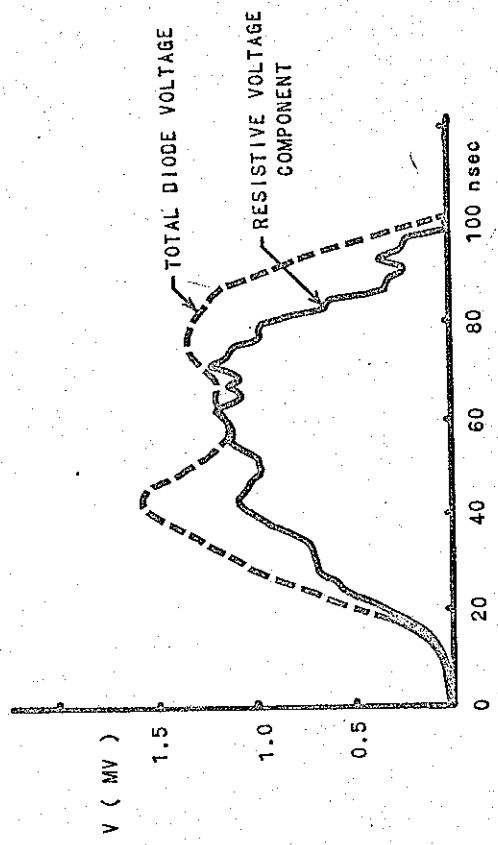
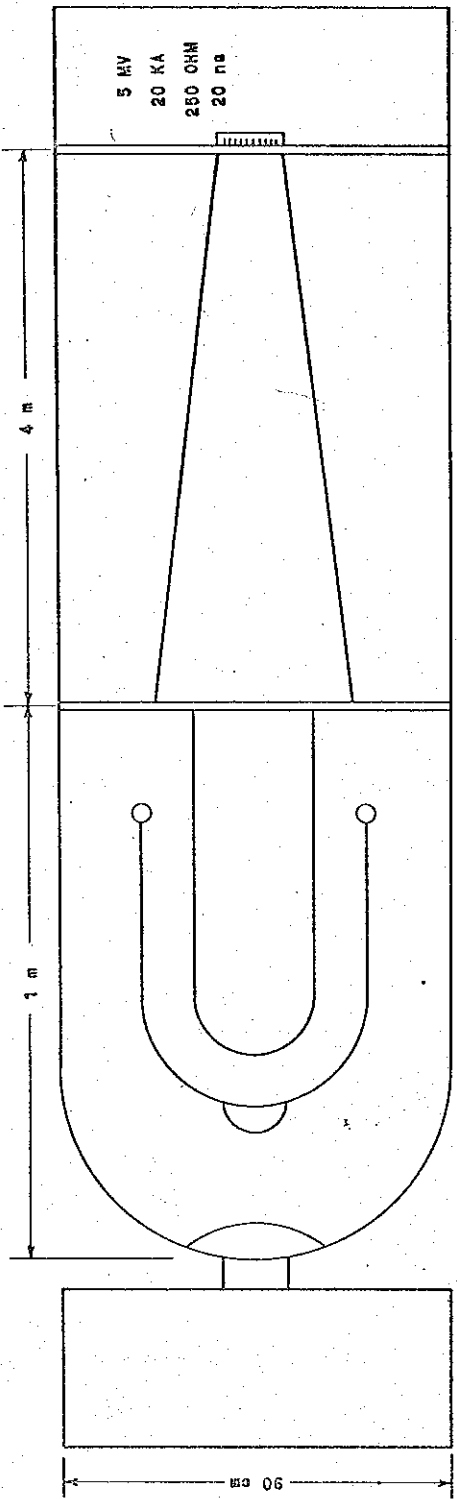

Figure 4.



HIGH IMPEDANCE DIODE SECTION

OIL COAXIAL TRANSFORMER SECTION
(42 OHM INPUT; 80 OHM OUTPUT)

WATER BLUMLEIN SECTION
(10 OHM)

1 MV MARX

Figure 5.

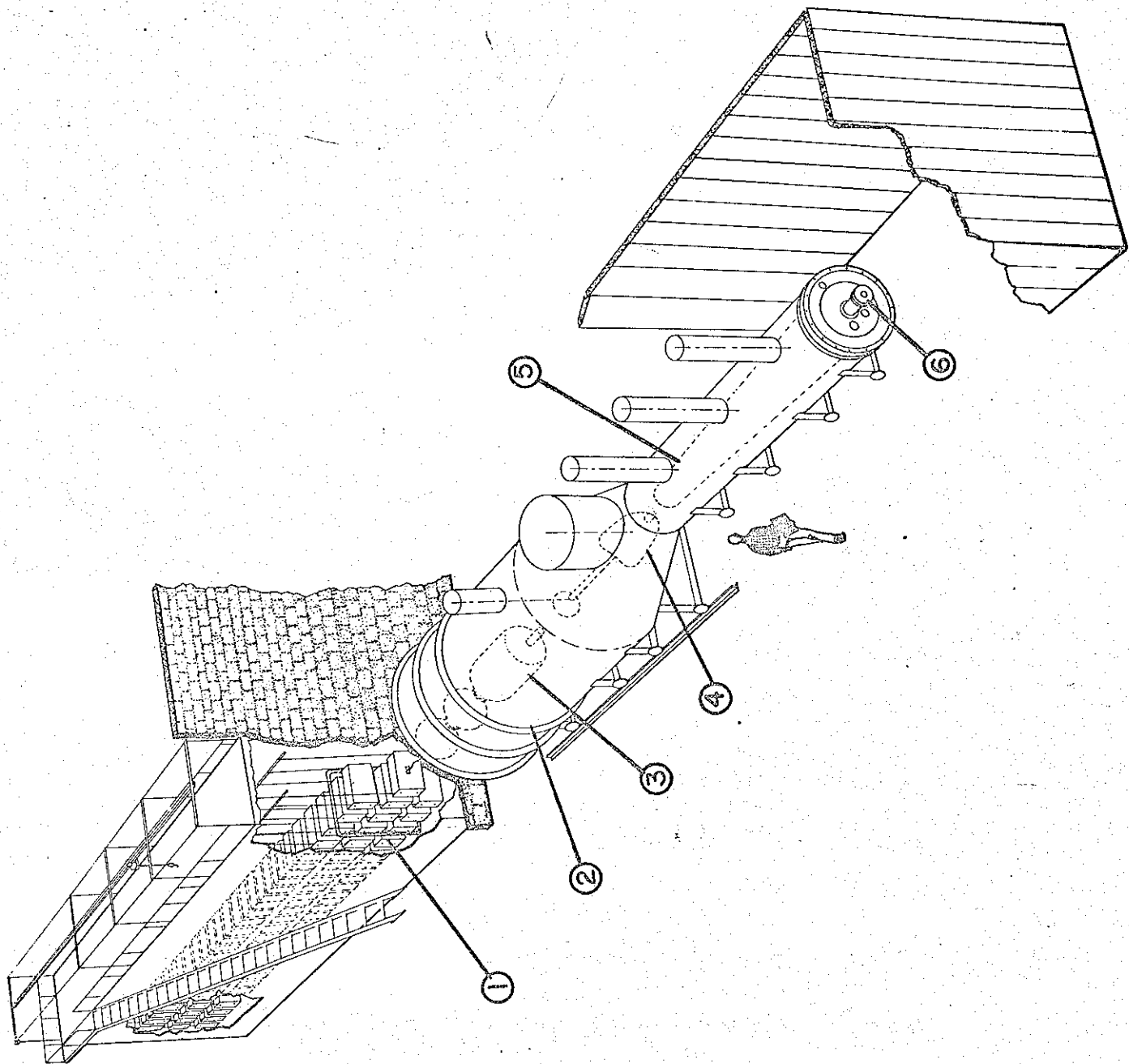

Figure 6.

PARAMETERS OF INTENSE RELATIVISTIC ELECTRON BEAMS

—ELECTRON ENERGIES	100 keV	-	10 MeV
—BEAM CURRENTS	10 kA	-	1 MA
—PULSE WIDTHS	10 nsec	-	100 nsec
—BEAM ENERGIES	1 kJ	-	1 MJ

Table 1.

NRL RELATIVISTIC ELECTRON BEAM GENERATORS

	7 OHM LINE	ERA INJECTOR	GAMBLE I	GAMBLE II
TYPE	COAXIAL WATER BLUMLEIN LINE	COAXIAL WATER AND OIL LINES	COAXIAL WATER TRANSMISSION LINE	COAXIAL WATER TRANSMISSION LINE
MEAN LOAD IMPEDANCE	7 OHM	250 OHM	1.5 OHM	0.7 OHM
ELECTRON ENERGY	500 keV	5 MeV	750 keV	900 keV
BEAM CURRENT	70 kA	20 kA	500 kA	1.3 MA
PULSE WIDTH	50 nsec	20 nsec	50 nsec	50 nsec
BEAM ENERGY	1.7 kJ	2.0 kJ	20 kJ	55 kJ

Table 2.

ELECTRICAL PARAMETERS OF THE GAMBLE GENERATORS

	<u>Gamble I</u>	<u>Gamble II</u>
<u>Marx Generator</u>Capacity	12 nF	4.1 nF
Output Voltage	3.3 MV	6.0 MV
Energy Stored	66 kJ	228 kJ
<u>Intermediate Storage Capacitor</u>Capacity	8.7 nF	7.4 nF
Voltage	3.7 MV	6.0 MV
Energy Stored	60 kJ	133 kJ
<u>Pulse Forming Line</u>Transmission Line Impedance	4.0 Ohms	5.8 Ohms
Capacity	6.25 nF	4.3 nF
Voltage	4.0 MV	6.8 MV
Energy Stored	50 kJ	100 kJ
Output Pulse Duration	50 nsec	50 nsec
<u>Coaxial Transformer</u>Input Impedance	4.0 Ohms	5.8 Ohms
Output Impedance	1.53 Ohms	1.53 Ohms
Output Voltage	1.0 MV	1.0 MV
Design Load	1.0 Ohms, 20 nH	0.6 Ohms, 20 nH
Energy Delivered to Load	32 kJ	60 kJ

Table 3.