

Circuit and Electromagnetic System Design Notes

Note 15

February 1973

PULSE CHARGED LINE FOR LASER PUMPING

J. C. Martin
Atomic Weapons Research Establishment
Aldermaston
England

Originally published as
SSWA/JCM/732/373



INTRODUCTION

The aim of this short series of experiments was to show the feasibility of a generator providing a current of about 300 kA with a maximum rate of rise of about 8×10^{13} amps per second, by means of a cheap, simple system. In addition, it was desirable that the generator should use gas switches, so that the rate of firing could be a few a minute. The above requirements meant that the approach used by John Shipman of NRL (which uses triggered solid dielectric switches) would not be satisfactory. John Shipman's elegant system provides a short circuit current of 500 kA and a slightly faster rise to the current pulse, but it was felt that even though the performance of the new system was going to be poorer, its speed of operation and cheapness would compensate for this.

There was not time in the 6 weeks available to build a full system (whose width of lines would be about 1.4 metres) so a 60 cm wide strip of it was built, mainly to test the multichannel operation of the start and pulse sharpening gaps and to check out other features of the construction of the lines. Two people were engaged on the building and testing of the sub system and the work was terminated a little prematurely by one of them (JCM) getting plastered (the right leg). However, it was felt that demonstration of all the main points had been achieved and that with only a modest amount of further development the full system could be made to work.

OUTLINE OF SYSTEM

The basic generator is a strip line Blumlein circuit. The Blumlein circuit is normally shown with 2 equal impedance lines (Z) and when charged to V_0 and switched with an ideal gap, provides an output voltage of V_0 into the matching impedance of $2Z$. The duration of the pulse is the two-way pulse transit time. However, there is no need for the lines to be of equal impedance: they can be unequal and in this case it is desirable that they should be. Neither need they be of equal length and again, in this application it is functionally desirable to make the unswitched line significantly shorter.

Fig. 1 shows the schematic of the Blumlein employed and the equivalent circuit. Switched with an ideal gap, the first pulse duration is now that of the two-way transit of the shorter line. Thus, if the load R approximates to a short-circuit, the current provided will reach a value of $2V_0/Z_1 + Z_2$, with ideal switching. In practice, if the start switch has a rather slow rise, the pulse voltage across R will have a poor rise and also not reach the ideal switch voltage value in a finite length line. The second point is not as serious as the first from a laser application point of view.

The rise time of the start gap was expected to be 30 ns or so, far too slow to provide good laser pumping. However, this difficulty was to be circumvented by providing a pulse sharpening gap to the left of the load. This gap would be much more quickly charged than the start gap and hence would be more compact and could be operated at higher fields and with many more channels than the very much more slowly charged start gap. However, the use of a pulsed sharpening gap throws away the first 20 ns or so of the rise of the pulse before it closes, providing the fast rising pulse to the load. However, the gas in the lasing cell only provides an output for a few ns, so the length of the right hand part of the Blumlein needs only be some 10 ns in electrical length, while the left hand line needs to be some 30 ns.

Figure 2 shows the circuit with the pulse sharpening gap in it and also gives representative wave forms.

A major objective of the experiments described here was to show that the pulse sharpening gap would go into proper plasma conduction channels quickly, since recent Russian work has shown that uniform field unpressurised gaps had a fairly long (~ 10 ns) phase when current is carried in broad columns of ionised gas before the thin plasma channels form. This gives a poor rise to the output pulse. This phenomenon had been seen in edge plane gaps charged in times like 100 ns, when significant current occurred before the rapid voltage collapse phase took place ('fizzle'). It was known that this phase got much shorter as the gas was pressurised: however, it was not certain that in terms of a few ns the phenomenon had disappeared with pressurised edge plane gaps. Indeed, with carbon dioxide it was found that the fizzle phase was significant at quite high gas pressures.

CHOICE OF START GAP

While it was clear that the sharpening gap should be a pressurised edge plane gap, there were two choices as to what the start gap should be. The two distinct systems would have been a DC charged Blumlein system with a triggered uniform field rail gap, or a pulse charged line with an edge plane gap. For the DC approach, the uniform field gap would still have to be operated multichannel and this would have required a fast trigger pulse and, even with this, multichannel operation of a DC gap at 70 kV has not been demonstrated with an adequate number of channels, to my knowledge. However, edge plane gaps have been operated with an adequate number of channels. (Multichannel Gaps, J. C. Martin, Switching Note 10, referred to in future as 'The MC Note'). The use of edge plane gaps, however, meant that the Blumlein would have to be pulse-charged quickly and this would require the addition of a low inductance small bank to the system. A secondary advantage of this approach was that tracking problems would be much eased by pulse charging. A DC

charged 70 kV line can be run in air, but very considerable care is needed to prevent tracking around the line and the start gap. However, a pulse charged line can easily be made and indeed during all the tests no tracking around the line was observed at any time, despite the edge grading getting pretty grotty at times.

Thus, to enable an edge plane start gap to be used and to ease tracking problems, a pulse charged Blumlein approach was selected. In retrospect I think the decision was a good one. However, a DC charged system with a multichannel uniform triggered gap would be simpler (once the development work had been done) and almost certainly is feasible, but would require significantly more development work, in my opinion.

Thus the final schematic of the system is as shown in Figure 3.

The inductances L_1 and L_2 , are selected so that the two roughly equal capacities of the two parts of the Blumlein charge at the same rate, preventing a significant prepulse appearing across the pulse sharpening gap.

The 60 cm wide system will now be described and the results obtained with it given. The full system will then be outlined and some comments given about its testing and expected operation.

60 CM WIDE LINE

1. BANK

The small bank consisted of two AWRE-made 100 kV condensers in parallel with a rail gap at one end and the pulse output at the other - see Figure 4. The capacitors are low inductance and have a value of 70 nF each. The tabs of each winding in them are brought out on one face and form a low inductance line when the return conductor is placed close to this face. The spark gap is a pressurised rail gap in a 2" OD perspex cylinder with 0.5 cm wall thickness. The rods which form the two electrodes are 5/8" OD brass rod, 6" long, and are spaced 0.60 cm apart in this gap (which is not optimum but just one that happened to be available). The ends of the brass rods are shaped as shown in Figure 5 and rounded in all dimensions, so that the field decreases away from the maximum value it has in the central portion of the rail gap. This shaping is not critical and after carving off the brass bits indicated can be done with a coarse file in about half an hour for a pair of electrodes. No very perfect finish is required, but a rough polish with one grade of sandpaper is used after a smooth contour has been filed.

The low inductance connections between the spark gap and the capacitor are shown in Figure 6. There is a flux excluding prism which also stabilises the voltage at the mid plane of the

gap at $V/2$. Where the gap is charged 0 , V this metal insert is allowed to float at $V/2$. Where plus and minus charging is used (which is the preferred arrangement, but was not used in the 60 cm tests), the metal flux excluder is earthed via a few kilohm resistor chain. The fact that the surface voltage gradient is divided into two half voltage gains because surface tracking goes at V^2 or higher. There are also $\sim 1/16$ " flat sheet perspex guards simplexed onto the perspex tube and the mylar insulation of the main line is twin stuck against the spark gap body. Additional sheets of mylar are included around the main feeds. The flux excluder (which lowers the inductance of the gap significantly) is made by wrapping ~ 4 thou copper around a wooden triangular cross-section prism. This in turn is covered with double-sided sticky tape holding a mylar wrap down and the smallest face is then twin stuck to mid plane thin perspex sheet. The construction and insulation external to the gap is very similar to that of the start gap, which will be sent to the builders of the 140 cm line.

The DC breakdown of the gap can be calculated to a couple of percent, using the treatment given in DC Breakdown Voltages of Non Uniform Gaps in Air, Dielectric Strength Note 16.

The calculated and experimental breakdown values for air are given below. These values apply after the gap has been fired a few times initially to condition off projections and whiskers. The breakdown channels should be distributed over the central region of the rods and not occur frequently (if at all) at the curved ends, if their shaping has been done correctly.

TABLE I
DC BREAKDOWN OF THE RAIL GAP

P Absolute (atmospheres of air)	V Breakdown Calculated (kV)	V Breakdown Observed (kV)
1	21	20
2	37.5	37
3	54.5	52.5

It might be as well to insert a word of explanation about all the calculations in this note. These are essentially designer's calculations and are only good to 10 per cent, or even poorer. In other words, these are designed to act as good estimates before manufacture and as a check that operation is as intended, as the system is made. The only real test of the system is that it performs as required at the end of the day: however,

it is useful to check numerically that everything is roughly going according to plan at each stage, so rather crude calculations of expected performance are made before testing each stage and it is ensured that these agree tolerably, but not slavishly, well before proceeding to the next one.

The calculation of the inductance of the bank and switch up to the output strip transmission line is given below, as an example of how it is treated. Again, only crude approximations are used because this is all that is justifiable without a great deal of work which would be a waste of time and uneconomical.

INDUCTANCE OF SPARK GAP

SPARK CHANNEL

The plasma column expands at the rate of $\sim 3 \times 10^5$ cm/sec and hence at ~ 50 ns the channel radius is $\sim .015$ cm and the radius of the rod is $\sim .4$ cm. Hence the inductance of the plasma channel at the time of interest is given by

$$L \sim 2 l \ln b/a$$

where l is channel length, b rod radius and a channel radius.

$$\text{So } L_{\text{spark}} \sim 2 \times 0.6 \times \ln 30 \\ \sim 4 \text{ nH.}$$

The rail feeds to the channel have an inductance along them of about 4 nH/cm. The channel is fed from two directions and assuming the rails (width w) are fed uniformly along their length, the inductance

$$L_{\text{feed}} \approx \frac{4 \times w}{12} \text{ nH}$$

$$\text{i.e. } L_{\text{feed}} \sim 5 \text{ nH.}$$

There is then the fact that the rails are fed only in three places (4 cm apart) by short connectors through the perspex spark gap wall. Each of these stubs has an inductance of about $2 \times 0.7 \times 2 \sim 3$ nH and hence $L_{\text{stubs}} \sim 2$ nH. The copper feeds widen as they leave the spark gap to lower the inductance, but taking them as still being ~ 15 cm wide, the inductance of the area inside and just outside of the spark gap shaded in Figure 6 is given by

$$L_{\text{gap body}} \sim \frac{12.6 \text{ Area}}{W} \text{ nH}$$

$$\text{i.e. } L_{\text{gap body}} \sim \frac{12.6 \times 14}{15} \sim 12 \text{ nH.}$$

Thus the spark gap inductance $\sim 23 \text{ nH}$.

In addition to this there is inductance of the short feed between the spark gap and the condenser $\sim 2 \text{ nH}$, giving an inductance up to condenser $\sim 25 \text{ nH}$.

The capacitors each have an inductance of $\sim 25 \text{ nH}$, giving 12 nH in parallel. There is $\sim 3\text{-}4 \text{ nH}$ in the low inductance beyond the capacitors, giving a value all up of $\sim 40 \text{ nH}$. (Which, by experience, is usually a little bit on the low side).

The measured value was obtained by firing the bank into a short circuit at $\sim 25 \text{ kV}$ and was found to be about 45 nH and also gave an internal resistance of 0.2 ohm approximately from the damping. The capacitor internal resistance depends a bit on frequency but is of the order 0.4 ohm each from previous determinations, in good agreement with the above.

Thus the bank basic characteristics are as given in Figure 7. The bank should not be rung repeatedly at high volts into a short without any extra damping, as this reduces the capacitor life: however, at 70 kV it would give 90 kiloamps approximately into a short. The bank is simply fired by just reducing the gap pressure by venting the compressed air. The air flow is arranged so that the fresh air is introduced at the bottom of the gap and exhausted at the top of the cylinder and the rate of change in general for gaps should be about once every shot, but this is not at all critical and can be much lower for this gap which can be over-pressurised. The gap body can take well over 100 psig and is tested to this value after construction, while wrapped in waste cloth, in case it were to blow up. It is normally run at 30 per cent over the breakdown pressure and is automatically flushed when the pressure is lowered to fire it.

THE LINES

The lines shown diagrammatically in Figure 2 were made 250 cm long from the start gap to the pulse sharpening gap and 110 cm beyond to the end of the system. Initially the insulation of the LHS line was a total of $2 \times 1/32''$ polythene and $4 \times 2 \text{ thou}$ mylar. The RHS was insulated by $4 \times 2 \text{ thou}$ and $3 \times 5 \text{ thou}$ mylar. The impedances of these (if perfectly assembled) would have been about 0.76 and 0.20 ohms respectively for a 60 cm width, giving a total Blumlein output impedance of 0.96 ohm . However, life is not quite that simple, because in a practical assembly there are thin films of air between the dielectric

sheets. This has two effects: firstly these air films may increase the impedance somewhat (up to 10 per cent), and secondly (and more importantly) these air films break down during the pulse charging of the lines, increasing the capacity of the lines viewed as a "lumped constant" capacity. This introduces a $(dc/dt)^{-1}$ term into the charging circuit of the low inductance bank, causing increased dumping and reducing the ringing gain from the bank to the lines. Thus it is desirable to assemble the lines in such a way that these air films are as thin as it is practically possible to achieve.

The method used to achieve a good assembly is to put the dielectric layers between fairly thin copper sheets (3 to 4 thou) and then push them together with a steady DC pressure. This is achieved by placing the lines between two 1/2" plywood sheets which are faced on the inside with spongy 1/4" sheets of rubber. This rubber needs to be pretty compressible (~ 70-80 per cent air) and when localised loads are placed on top of the sandwich, the plywood acts as a stiff member, flexing only a little under them, and the spongy rubber applies essentially uniform pressure all over the copper dielectric line. In actual practice, 6" concrete cubes were available to load the line (weighing about 20 lb each) and some 25 of these were distributed over the top of the sandwich, giving a pressure of about 10^{-2} of an atmosphere to assemble the lines.

After the line has been fired a number of times, charge separation occurs inside the line and this leads to additional electrostatic assembly forces which help to compact the line. As an example of what can be achieved, the capacity of the LHS was calculated to be 15-1/2 nF with no air present and the measured capacity was 12.6 nF after a fair number of firings. Thus, in addition to the 70 thou or so insulation, there was only some 6 thou of air. For the RHS the calculated capacity (allowing for extra insulation under the load and near the peaking gap) was about 26 nF, while the measured capacity was 17-1/2 nF. This indicates that in addition to 21 thou of mylar there was some 3 thou of air, on the average. There are as many interfaces on the RHS as on the LHS, but the mylar here is thinner and lies flatter than the dielectric on the LHS.

Figure 8 gives a sketch of the cross-section of the line near the edge of the copper, showing the details of the edge control as well as those of the line construction.

A few notes about the construction of the line follow. The sponge rubber is Evo-stuck to the plywood (Evostik is an impact adhesive). A layer of 2 thou mylar is then stuck to the rubber face. The copper line is stuck to this mylar with two lengths of 3" Twin stick double-sided tape. The edge tracking control blotting paper is then stuck outside the edge of the copper with Twin-stick. The dielectric layers are then placed in position and the top assembly then placed above and weighted down.

EDGE CONTROL

As the line is pulse charged, very big stresses are generated to the edge of the copper lines and in the absence of tricks to smear out these in a controlled way, flash round may occur. The tricks used in this line are threefold. Firstly the copper is bent back on itself (1/2" or so), giving a smooth edge of twice the thickness of the main copper. In addition, the space between the mylar sheets stuck to the sponge rubber immediately adjacent to the copper edge is filled by blotting paper or filter paper for a width of about 1-1/2". This edging can be conveniently made by sticking lengths of the paper to 3" twinstick and cutting this up the middle. It is very desirable to use a porous paper for the edge control and not to fill up the space with solid material, otherwise the necessary grading at the edge will not occur by coronoring and edge puncture of the main dielectric may well take place. The third trick is to fold the top and bottom 2 thou mylar up and down over the plywood/rubber, so that any tracking that does get as far as the edge of the wood is forced to move away from the final edge of the dielectric, breaking the field here into a series of disconnected regions, each holding only a fraction of the voltage.

GAIN FROM THE BANK TO THE LINE

In theory, it is a simple matter to calculate the ringing gain of the Bank/line when the latter is viewed as a "lumped constant" capacity. Figure 9 gives the relation for a loss-less circuit and also a reasonable approximate gain for a circuit with a series and parallel resistance, valid when the damping is not too large. The difficulty in applying this relation is in defining what R_p should be. Any real resistances can obviously be allowed for, but there are two additional effects which decrease R_p . One is the air breakdown within the lines, mentioned above, for which an estimation can be made. Certainly the value of C_1 to be used is near the theoretical or no-air one, as the air must break down at operating voltages on the lines. This is because the field in the air reaches values of 1 MV/cm or higher. The air when it breaks may not become totally conducting when looked at from the point of view of a pulse travelling up the line, but during the relatively slow charging phase, the capacity must rise to close to the theoretical value. Another dc/dt term arrives from corona moving out from the edges of the line. This effect is minimised by the edge control techniques mentioned above (sealing the edges of the copper completely will just lead to main dielectric breakdown, a phenomenon exploited in solid dielectric switches), but it still exists and it, too, causes a reduction in R_p .

An estimation of the ringing gain to be expected will be given later in this note, as an example.

After the line had been used for a while to do various tests and to make some edge plane breakdown measurements, its impedance was reduced by removing one of the 1/32" polythene sheets from the LHS, this giving an impedance (complete air breakdown) of 0.42 ohm and a generator internal impedance of 0.62 ohm, with air breakdown, and 0.72 ohm if the air did not break down completely. To cover the two possibilities, the line impedance would be taken as 0.65 ohm which probably closely corresponds to the impedance of the second version of the line.

There is an effect due to the fast rate of charging of the line. Typically the \sqrt{LC} of the bank charging is of the order of 40 ns. The "effective" \sqrt{LC} of the LHS line, the longest, is about 8 ns, thus there is a significant voltage drop down the line, if it is fed at the sharpening gap, and the voltage at the start gap may be ~ 10 per cent lower, since it fires before peak volts. However, this is only of real importance in measuring the breakdown voltage of the gap; the pulse travelling up the line is, of course, the voltage across the start gap when this fires. This effect is minimised by taking a little care about the location of the feed point of the lines from the bank. The start gap is arranged to fire near, but before, peak volts on the charging waveform, in order to achieve multichannel operation, and it is the time of this breakdown on the waveform which decides the actual difference between start gap volts and feed point volts.

START GAP

The actual start gap will be sent to those intending to build the large system, so that an extensive description of the gap and its insulation can be avoided. However, Figure 10 gives a sketch of the gap. The perspex body is 1-1/2" OD, with 3 mm wall thickness, and the "plane" electrode is made from 1/2" brass rod. The edge is made from 1/32" thick strip, which is 1.1 cm wide. The gap between the edge and the rod is 0.70 cm and is uniform to about .005 cm. The length of the rod and edge are about 8" and the uniform length some 16 cm, the ends of both rod and edge being curved back as in the bank gap, but done rather crudely in this case. The brass strip is sharpened, rather poorly, by filing at an angle of about 20° and with a final edge radius of about 0.01 cm. The overall length of the gap is about 15", including the demountable pressure caps at either end.

The two electrodes are fed in four places each along their length, brass fittings on the outside of the gap containing small O rings and also pressing down onto the 3 thou copper of the output feeds to make electrical contact, as well as gas sealing. The inside of these stubs are fitted to the edge by slotting and then soft soldering. This method is fundamentally sound, but hard soldering should have been used instead of soft, as the stubs could be torn off by the over-enthusiastic use of the spanner.

The line tapers from the 20 cm or so of the switch out to the 60 cm of the line over a distance of some 30 cm and the insulation thickness is reduced over this region to a little under a half of what it is in the main line, in order to keep a roughly constant impedance. The insulation in this region is quite tricky and the use of Twinstick has been minimised, because it has an appreciable thickness in its own right.

In retrospect, the start gap was made too narrow and it would have been better to have electrodes some 35-40 cm wide. It was the first small pressurised E/P gap I had made and I was not sure how difficult it was going to be to fabricate it, when made by largely unskilled labour. As it turned out, it proved quite easy to make and a very fair uniformity of gap was obtained even when made by an amateur in a couple of days. The consequence of making it too small in length was that even when it operated multichannel (which it did with delightful regularity), its inductance was quite big and the resulting pulse travelling up the line had a poor rise (e folding ~ 25 ns at best).

THE SHARPENING GAP

Figure 11 gives a sketch of the gap. The electrodes are 55 cm long and the overall length of the gap about 85 cm. The "plane" electrode was made from 1/4" OD brass rod, while the edge electrode was made of strip 0.6 cm wide. The edge of this was filed down to a 15° angle and the final radius was about .005 cm. The gap was 0.61 cm, but the variation in this was up to 0.02 cm. This came about from over-confidence, leading to failure to drill the holes in the perspex tube at regular enough intervals. Despite this big variation in gap width, up to 40 channels were observed, although there was a definite series of bald patches where the gap was bigger than average. There should be no difficulty in holding the spacing constant to .005 cm when the gap is made properly. It may pay to thicken up the strip slightly to, say, 50 thou, to get extra stiffness.

Both electrodes are fed every 2" by stubs through the tube wall and make contact electrically to a square section brass bar which has 0 ring cones drilled in it at each stub point. The pressure scaling was quite satisfactory up to 80 psig, except when a stub was pulled off the edge strip by over-enthusiastic use of the spanner and/or poor soldering.

The bottom of the gap is sealed to a 3" wide, approximately 2 mm thick, perspex sheet by some careful simplexing. The bottom of this perspex sheet is twinstuck to the insulation of the line and at up to voltages of 90 kV across the gap, no tracking at all was observed. The pulse volts are on for an effective time of only a few ns, of course, which helps enormously in easing tracking at this point.

In the real application the start gap will be inclined across the strip line at an angle to the voltage front, but in these tests it was at right angles to the long length of the lines. The length of the sharpening gap in the full system will be some 200 cm and while it can be made in one piece I am sure, there is no reason why the electrodes cannot be made in, say, 60 cm lengths, or even three gaps can be made and simplexed end to end without degrading its performance significantly, providing the edge plane spacing is maintained constant throughout, should a single gap prove difficult to make.

This completes the description of the major items in the system. It is worth giving a few general remarks about the accuracy with which everything is made. In general, the assembly can be very poorly toleranced. Very little in the system need be carefully made and great care does not have to be taken over any part of it, with the exception of the gaps. Here there are three regions where some care has to be exercised. Firstly the insulation wrapping to prevent tracking should be done with some care. Secondly the gaps have to be pressure tight. Thirdly the gap in the edge plane should be held constant to better than 1 per cent. This will mean over a considerable length the standard deviation of the gap will be some ± 0.2 per cent. The absolute value of the gap is not too important, since this can be corrected for by changing its operating pressure, but it should be within, say, 10 per cent of the ones built for the 60 cm line tests.

In addition to the fact that the system can be fairly crudely made (except where noted), the numbers given in this note may not be exact and errors may have crept in on occasions; again, this is not of major importance. So the calculations given, while in the correct ball park, may not be exact to a few per cent; even so, they are probably better than the theory justifies.

ARRANGEMENTS OF EXPERIMENTS AND MONITORING

Initially, as was mentioned above, the bank characteristics were measured and checked against theory. The next set of experiments were carried out with the LHS line only in place, but with the start gap in position. This was over-pressurised so that it did not break. Some 30 ohms were placed across the line at the end remote from the start gap, in the form of 3 parallel chains of 8 resistors each. A signal was tapped off one resistor in one chain to monitor the waveforms. The ringing gain was then obtained and the operation of the start gap investigated for a range of gases at different pressures and for each polarity on the sharp edge. The ringing period of the line was investigated and also the rise time of the pulse from the start gap.

The sharpening gap was then built and placed in position and the line on the RHS of the system finished. The charging rates of the two bits of line were then balanced to give as small a prepulse as possible. The main monitor at this time was a chain across the LHS line just before the sharpening gap. This consisted of a chain of ten 10Ω resistors tapping off one or two into the 100Ω cable of the 'scope. To measure the out-of-balance signal, the 'scope cable was placed straight across the sharpening gap. In addition to these monitoring points, the load had been represented by $100 \times 10 \Omega$ resistors in parallel across the width of the line, giving a nominal 0.1Ω series resistor. These were mounted in the line in a low inductance way and acted as a current monitor. The resistors used in this monitor were not the same as those used elsewhere in the monitoring, being physically rather smaller.

The system earth was arranged to be at the top line, just before the sharpening gap. In order to reduce earth currents, a 600Ω approx resistor was placed in the earth line from the bank, comprising 8 large 1 watt resistors, 2 in parallel, 4 in series. There was also, of course, a resistor in the charging lead from the power pack (2 megohms). Thus the system was DC earthed in two places (three when the safety dumps were down on the power pack) but had only one earth (that of the signal cable) from a pulsed point of view. Even this was not a direct earth for the medium-high frequencies, because of another pick up suppression technique we employ. This consists of winding some 50 yards of mains lead on a cardboard or plastic drum to form an inductance of the order of a millihenry. This acts as a choke for the high frequencies (of impedance of the order of kilohms or greater) and limits the current flowing in the earth conductor of the coax to tens of amps rather than kiloamps. For low frequencies and DC, of course, the 'scope is still earthed. When this trick is used it is necessary to put $0.1 \mu\text{F}$ bypass condensers between both live and neutral to earth at both ends of the mains inductor. This is because equal pulse currents flow down the three cores of the mains lead.

For very high frequencies, the earth of the system is not definable anyway, and it radiates in a more or less balanced way before settling down with something tending to zero on the top plate.

The 'scope used in the experiments has a number of unusual characteristics and is a home-built system. The tube is an old Ferranti tube (made in limited numbers and no longer available) which has an accelerating potential of 20 kV, magnetic focusing and a twin line x deflection system consisting of two rods crossing the tube with the beam passing between them. The deflection sensitivity is very low ($5\text{-}1/2$ kV/cm on the film) which is a very useful characteristic when measuring high voltage pulses, because it makes the attenuators simple to build. This tube was the first one to write faster than the velocity

of light about 15 years ago. The active electronics in the 'scope is a single spark gap which provides the deflection sweep and brightening pulse. The sweep is approximately exponential, which we have found to be a useful feature in most of our work. The whole system is remarkably immune to pickup and, indeed, on one occasion we floated one of these 'scopes up to 1 million volts on a microsecond pulse and then recorded a high speed pulse, a situation that most 'scopes would not be happy in.

With the particular version of the 'scope we were using, the tube HT voltage was quite stable and hence the X deflection constant, but the sweep deflection system was somewhat time-dependent. However, whenever the time measurements were important, a calibration was done before and after the shots. The exponential nature of the sweep was also a minor inconvenience in some of this work, but, in general, the very fast response time of the 'scope (see the later section on output pulse rise time) and its immunity to pick up were very considerable advantages. The only reason that a brief description of the 'scope has been included is that it explains various unusual features of the waveforms obtained.

Any fast 'scope (better than or equal to 100 megacycles response) should be able to perform quite well, but more care will be needed with the attenuation, and with pick up suppression, than we had to use.

There was one additional feature added to the bank which has not been mentioned to date and that is the location of a 40 ohm resistor across the pulse output of the condensers. This consisted of some 40 large 1 watt resistors in a series parallel arrangement and had two functions. Firstly it provided a load to discharge the system, if the bank were fired and the start gap did not break, thus discharging the lines in a few microseconds and so avoiding a late time track around the edges of the lines. Secondly it added to the damping of the oscillations in the bank circuit in such circumstances to prevent it ringing on too long. This is not very important but as a general policy we do not like capacitors and gaps to ring through too many cycles. The resistive load across the capacitor could not be too low in value, as it would affect the ringing gain of the charging circuit, so that the value chosen was a compromise, on the high side.

The last item to be mentioned in this section is the resistors used in the system. Except for the Oil Blumlein output load/current monitor, these were old-fashioned 1 watt ceramic cased composition carbon resistors (size 3 cm long by 1 cm in diameter). These resistors can be used as delivered up to 15 kV per resistance, for high speed pulses such as those encountered in these experiments. They will absorb up to 2 joules without any significant change in resistance, either pulse or DC, and

can be used up to about 5 joules with some slight drift, which, however, can be cancelled out in a potential divider arrangement. Around 8 joules per pulse they blow up. Unfortunately, our Stores no longer stock these, but now use physically much smaller resistors and while we have some stocks of the old type, when we had to make up the 0.1 ohm resistor we had to use the more modern type. These we have not tested for high voltage pulse operation, but we have looked at a range of American resistors in the past, of very similar size. These all showed DC changes at significantly lower overall voltages and energy depositions (reasonable because of the small length and lower volume) and in general if a 10 per cent DC drop in resistance was found after a number of pulses, then the impedance was down 30 to 40 per cent during the high voltage pulse. This is indeed what happened to the output load and is discussed further towards the end of this note. Such resistors would still be useable in a voltage monitor providing the signal is taken off one of a chain via a high impedance feed, so the tap off resistance had essentially the same voltage pulse on it as would the others in the chain.

Figure 12 shows how the voltage monitor was attached to the line. An essentially similar method of construction was used to make the attachment between the bank and the two lines. This attachment also formed the two inductors, but because it was required that these feeds should not have more than 40 nH or so, the feeds were 8" wide and were attached to the lines through long slots in the plywood. The feeds were also only about 1 cm apart over most of their length and were wrapped in sheets of mylar and had curved up edges, to prevent flash-over during the charging pulse.

60 CM LINE RESULTS

RINGING GAIN

The ringing gain results will be given for the second version of the line, where the calculated capacity of the LHS was 30 nF and the observed 24 nF, while those of the RHS were 26 and 17-1/2 nF respectively. This version was the one with only one sheet of 1/32" polythene in the LHS line. Figure 14 gives a tracing of the waveform for bank volts of 30 kV and gives a first peak gain of 1.13 and a half period of 150 ns. The reason tracings are given of the records is that it was intended to take a series of good records for this note at the end of the experiments, but this was not done as I had to go into hospital and was relatively immobile for a period of 5 weeks. During this time, various parts of the system had to be used for another investigation. This left only the records in the book and these were working records usually containing 4 or 5 traces on each print in order to save Polaroid film. As such, they are rather confusing and it was decided to trace representative records rather than have a lot of photographic reproductions

done which would not have been of high quality and would also have been rather confusing.

The value of the total load capacity being rung from the bank was bounded by the values of 41 nF (no air breakdown) and 56 nF (total air breakdown). The voltage on the bank was not very high (it could not be raised much higher because the start E/P would have broken later on in the wave form) and hence complete breakdown was unlikely and in addition the fact that some charge separation existed in the line after a series of firings, both suggest that the total air breakdown value would be too high. Thus a value about 50 nF for the load capacity is taken. This gives a value for the bank plus feed inductance of around 62 nH, based on a value of C_{eff} of 37 nF. This is reasonable, but perhaps a little low, since the bank inductance was 45 nH and the value for each feed inductance was estimated at about 45 nH, giving an estimated total inductance of around 67 nH. However, neither of the above numbers is better than about 10 per cent, nor is there much point in obtaining greater accuracy, as was mentioned earlier.

To get the calculated first peak gain, using the approximate relation given in Figure 9, a value of R_p is needed as well as the value of R_s , which is 0.2Ω approx. There is besides the dt/dc term, a 100Ω monitor and 40Ω across the bank. The dt/dc is estimated to be a time of $2\sqrt{LC_{eff}}$ equal to 100 ns and a capacity change of about 10 nF giving about 10 ohms. Thus $R_p \sim 7-1/2$ ohms, most of which comes from the dt/dc term (which cannot strictly be treated as a plain resistance, anyway). The first peak gain becomes 0.74 (0.74 + 0.76) which comes out very fortuitously as 1.12. This degree of agreement is highly accidental and an agreement to 5 per cent would be much more usual, and worse would not worry me much. The main virtue of these calculations is to suggest how improvements can be made. For instance, if the damping had mainly been in the series resistor, efforts might have been made to decrease this. Alternatively it is seen that the 40 ohms across the bank output was not contributing much to the loss of ringing gain. Also, if more detailed analysis of the waveform is made (allowing for the RC drop), a damping factor of about 0.67 per half cycle is obtained, compared with the one suggested by the above calculation of 0.75. However, this too has its errors, both in measurement and theory, so the disagreement may not be real. The treatment also suggests that at much higher voltages the gain may drop to only a few percent over one, as the air in the line breaks down more completely.

OUT OF BALANCE SIGNAL

Figure 14 shows a tracing of the out of balance signal across the sharpening gap, measured directly with the 'scope. The amplitude is about + 1.6 kV for 30 kV on the bank, ie about + 5 per cent. The record was the best obtained after a small amount

of fiddling, this being done by changing the spacing of one of the feeds, ie altering the inductance. I do not know what pre-pulse voltage can be applied to the E/P gap without altering its performance, but I would not think that a 5 per cent pre-pulse would have much effect. However, this can easily be tested, although we did not have time to do this.

START E/P GAP

Figure 15 is a tracing of a record of the operation of the start gap without the sharpening gap going. From this the breakdown field can be obtained for various gases and pressures. Most of the work so done was obtained with version A of the LHS and no RHS line, fairly early in the programme. This data, and also some derived from the sharpening gap, have been written up in "Results from Two Pressurised Edge Plane Gaps", J. C. Martin; I. Grimson; Switching Note 20. These results will not be covered again in this note. However, two points will be briefly covered. One is the apparent electrical length of the line and the degree of overswing shown in Figure 15; the other is the number of channels.

The apparent electrical length of the line deduced from Figure 15 is about 40 ns, considerably longer than the expected time of 25 ns. The explanation for this lies in the finite rise of the pulse from the start gap. The calculated rise time is dealt with more fully below, but can be taken as about 23 ns (maximum slope parameter) for the start gap working with about 10-15 channels in it. This pulse reaching the sharpening gap, which is open circuit, is reflected and returns to the start gap, at which it again reflects with a change of polarity, but in addition it is integrated by the inductance of the start gap, giving a pulse whose maximum slope is now about 40 ns, and this is delayed by about 10 ns more than the two-way transit time of 25 ns. The process repeats itself each time the maximum slope increases, the time at which this occurs being delayed as well. Figure 16 shows three successive pulses and the resultant waveform is sketched. The effect in the case shown is to increase the apparent two-way transit to about 42 ns and also the first peak voltage, instead of doubling, rises only to 78 per cent or so of this.

To check the real electrical length of the line, a solid gap was substituted for the start gap and this gave a two way transit of 25 ns. The rise time of this pulse here was about 7 ns (maximum slope). Even in this case (which was done with version A of the LHS line) the overswing was about 90 per cent of voltage doubling. The two causes of this were the fact that the voltage at the gap was less than at the monitoring point, as mentioned early. This was the major effect, but there was still a residual effect of the finite rise of the pulse from the gap. In the record shown in Figure 15, the lower impedance, version B, LHS lines were used and the rate of charge of the

line was significantly less and about 5 per cent of the failure to double is due to this effect. Thus the first reflected pulse would be expected to be about 73 per cent of voltage doubling; alternatively the overswing is 50 per cent of the initial switching amplitude, as the record shows.

As the maximum current the sharpening gap can drive is directly related to this peak to peak voltage, the poor rise time of the switch has a significant effect on the short circuit current after sharpening. In addition, the rate of rise of voltage on the sharpening gap is directly related to that of the start gap output pulse and this is one of the factors which controls the number of channels in the sharpening gap, and hence the rise time of the sharpened pulse. The major factor in the rise time from the start gap is the "external" inductance of the spark gap body and if this had been made twice as long, the start gap rise time would have been significantly improved, leading to more overswing and more channels in the sharpening gap.

The start gap inductive and resistive phases are not the only things which can give poor pulse rise times, as some gases show frizzle at pressures not much over one atmosphere. This is covered in the edge plane note and, for instance, carbon dioxide is particularly bad in this respect. As a result of the data obtained in that note, it was decided to use nitrogen of the gases tested, although air was not much inferior. In addition, the best number of channels was obtained from both the edge plane gaps with the edges being driven negative. But, again, the results with the edges positive were scarcely inferior. However, the data to be covered from now on will be given for nitrogen and negative edge polarity.

The number of channels in the start gap depends on the point on the waveform at which it is arranged to fire. In order to get as much volts on the line as possible, while still having a reasonable rate of change of voltage at the time of gap firing, it was arranged for the start gap to operate at about 90 per cent of the peak line volts. In fact, the number of channels was not a very rapidly varying function of this firing voltage, provided the gap closed before peak.

When the start gap closed at 90 per cent of peak volts, the number of channels was about 16, on average. An open photograph of two of the start gap firings is shown (Fig. 16A) on the page of photographs. The camera is simply tilted between records and some additional, rather faint, channels can be seen in the original Polaroid prints, which have been lost in the reproduction.

An approximate calculation of the number of channels to be expected will now be given. Familiarity with the multichannel note will be assumed. The inductance of the various parts of the gap will now be considered, as was done for the bank gap.

Spark channel radius $\sim 3 \times 10^{-3}$ $L_{\text{spark}} \sim 2 \times 0.7 \times 5$
 $\sim 7 \text{ nH/channel}$.

Inductance of feed to channel ($\omega = 15 \text{ cm}$) at 6 nH/cm

$$L_{\text{feed}} \sim \frac{15 \times 6}{12} \sim 7 \frac{1}{2} \text{ nH for 1 channel} .$$

Stub Inductance (4 stubs) $\sim 1.5 \text{ nH}$
 (each side)

Gap body Inductance $\sim 12.6 \times \frac{7}{20} \sim 4.5 \text{ nH}$.

The first two terms depend on the number of channels and give

$$L_{\text{in}} \approx \frac{16}{n} \text{ nH}.$$

The second two terms have to be added when deriving the output rise time of the pulse but are treated as part of the feed circuit when calculating the likely number of channels.

$$L_{\text{out}} \approx 6 \text{ nH}.$$

Considering first the number of channels to be obtained,

$$\begin{aligned} \text{thus } Z_{\text{eff}} &\sim Z_{\text{line}} + \omega L_{\text{out}} \\ &\sim 0.4 + 5 \times 10^7 \times 6 \times 10^{-9} \\ &\sim 0.7 \text{ ohms.} \end{aligned}$$

$$\text{Therefore } \tau_L \sim \frac{16}{0.7 n} = \frac{23}{n} \text{ ns}$$

where n is the number of channels.

Using representative breakdown fields, τ_R can be obtained and is

P psig	τ_R (ns)
0	$13.6/n^{1/3}$
14	$10.2/n^{1/3}$
22 1/2	$8.4/n^{1/3}$

Also $\tau_{\text{transit}} \sim 15/30n = 0.5/n$ ns .

This, depending as it does on $1/n$, can be combined with $0.1 \tau_L$ to give

$$0.1 \tau_L + 0.8 \tau_{\text{trans}} = 2.7/n$$

and Table II can now be obtained.

TABLE II

n	$0.1 \tau_L + 0.8 \tau_{\text{trans}}$	$0.1 \tau_R$			ΔT		
		p = 0	14 1/2	22	p = 0	14 1/2	22
1	2.7	1.4	1.0	0.8	4.1	3.7	3.5
2	1.3	1.1	0.8	0.6	2.4	2.1	1.9
4	0.65	0.9	0.6	0.5	1.55	1.25	1.15
8	0.3	0.7	0.5	0.4	1.0	0.8	0.7
16	0.15	0.55	0.4	0.3	0.7	0.55	0.45
32	0.07	0.45	0.3	0.25	0.52	0.37	0.32

Now T is required, which is related to the rate of rise of the pulse at firing time, and for breakdown at 90 per cent of peak volts $T \sim 2.2\sqrt{LC} \sim 110$ ns. Also σ is wanted. Figure 3 of the MC note gives it as 0.25 per cent for $t_{\text{eff}} \sim \sqrt{LC}$, which is for firing at 90 per cent of peak volts. To this must be added the jitter caused by the error in edge plane separation. In this gap the maximum change of gap was about 0.7 per cent, but this was a pretty uniform slope from one end to the other and the transit time helps to reduce the expected $\sigma \sim 0.17$ per cent (which would apply to a gap whose spacing varied

randomly by up to 0.7 per cent) to more like 0.1 per cent in this case.

$$\begin{aligned}\text{Thus } 2T\sigma &\approx 2 \times 110 \times (.0025 + .001) \\ &\approx 0.77 \text{ ns.}\end{aligned}$$

Using this value, the values in Table II suggest that the number of channels should be about 12 and only weakly dependent on pressure. This indeed was what was found after the gap had had some conditioning shots.

Cranking this number back into the earlier expressions for the gap inductance, one gets a value for this, when feeding into the line, as being

$$\begin{aligned}16/12 + 6 \text{ nH} \\ = 7.3 \text{ nH approximately}\end{aligned}$$

and not very dependent on the exact number of channels, most of the inductance coming from the external gap body term. Thus a two times longer gap would halve this term and also give more channels and thus essentially halve the above value. For the start gap as made

$$\tau_L = 7.3/0.4 = 18 \text{ ns}$$

$$\text{and } \tau_R = 5 \text{ ns}$$

giving an expected rise time of the order of 23 ns.

For a gap twice the width, the rise time (allowing for an increase in number of channels to about 20) would be about 14 ns (or a little more in real life, probably), a big improvement.

Once again the real value of the crude calculations is not to determine the exact number of channels to be expected so much as to locate the major terms in what controls this time, so that it can be predicted beforehand roughly, and also to suggest useful improvements in the construction of the system. In this case the external gap inductance is the controlling feature and this can be improved by using a smaller cylinder for the gap, or by increasing its length, the practically preferred route in a rebuild or new design being the latter.

The pressure in the start gap is denoted by p_1 and the approximate best value for this as a function of bank volts is

given in Figure 20, which also gives the optimum chosen value for p_2 , the pressure in the sharpening gap. As such, Figure 20 is a copy of the operating conditions graph for the 60 cm width line in its second version.

SHARPENING GAP PERFORMANCE

Once again the breakdown field data that were obtained for this gap are summarized in the edge plane note and will not be duplicated here.

Figure 16 shows tracings of a couple of records for different values of p_2 , the pressure in the sharpening gap. Again, these are for nitrogen with the edge negative. As the pressure in the gap is raised, the gap fires higher up the overswing, but at the time it fires the rate of change of volts is lower, hence a smaller number of channels results. Thus, while there are more volts to drive the load current with high values of p_2 , the rise time of the resultant pulse is poorer. As the RHS line is only some 10 ns long, the peak current reached in the 0.1 ohm load reaches a maximum value and then falls as the pressure is raised over the optimum. Thus the best condition obtained for these tests is where the sharpening gap is operating some half way down the overswing, but this is of course determined experimentally and will depend on the constancy of the edge plane separation, and also on the degree of overswing achieved, which depends in turn on the rise time of the start gap and the electrical length of the LHS line.

The second pair of photographs at the end of this note each shows two pairs of open shutter records of the start gap operation, the difference between the pairs in each photograph being the pressure in the sharpening gap p_2 . Here in particular there has been a noticeable loss of quality in the photographic reproduction (which was unavoidable) and many fainter channels have been lost and some of the brighter ones have coalesced. However, for the smaller value of p_2 in each case more channels can be seen. In addition, the bald spots where the edge plane gap was bigger, are clear, but with the greater rate of rise of the pulse at firing time these tend to fill in. The photographs were obtained with the aid of a mirror at 45° over the top of the sharpening gap and the camera was operated around f16, plus a neutral density filter of value 2.0 with Polaroid film speed 200. The start gap channels are significantly brighter, as they carry more current plus the ringing current of the bank. The aperture of the camera needs to be opened up as the number of channels increases, in order to keep the intensity of the brightest one roughly constant.

On the more routine of the shots, the number of channels was judged from the visual after-image and this was quite good for the start gap, but gave numbers like a half or less of the number recorded photographically in the case of the sharpening gap.

viewed at a distance of about 10 feet via the mirror. This is due to the eye lumping together, or not recording, those channels towards the edge of the field of view, I believe.

Table III lists the number of channels in the start gap and sharpening gap (recorded photographically) for a series of firings as functions of p_1 and p_2 for different bank volts, and also given is the peak deflection of the output current measurements. N_1 is the number of channels in the start gap and N_2 is the sharpening gap.

TABLE III

Bank Volts = 37 kV; $p_1 = 0$ psig; Average $N_1 = 16$				
N_1	p_2 (psig)	N_2	N_2 average	Current Deflection (cm)
17	0	39,32	35	.75
15	15	46,48	47	.77
15	22	38,40	39	.76
17	29	26,21	23	.70
Bank Volts = 45 kV; $p_1 = 15$ psig; Average $N_1 = 16$				
14	22	37,30	33	.90
16	29	37,37	37	.91
20	37	26,25	25	.90
14	44	16,13	14	.80
Bank Volts = 56 kV; $p_1 = 22$ psig; Average $N_1 = 15$				
18	29	38,35	36	1.10
18	37	35,32	33	1.13
10	44	29,27	28	1.14
16	52	18,30	24	1.08

From this, an "optimum" operating set of conditions was obtained for this particular run, which is given in Table IV.

TABLE IV
"OPTIMUM" CONDITIONS

Bank Volts (kV)	P1 (psig)	N1	P2 (psig)	N2
37	0	~ 16	20	40
45	15	~ 16	30	37
56	22	~ 15	40	32

The crude multichannel calculations will now be given for these conditions.

INDUCTANCE OF A SPARK CHANNEL

The spark channel radius is approximately 10^{-3} cm, giving

$$L_{\text{feed}} \sim \frac{55 \times 6}{12} \sim 27 \text{ nH for 1 channel}$$

$$L_{\text{spark}} \sim 2 \times 0.6 \times 6 \sim 7.2 \text{ nH/channel}$$

giving $L_{\text{in}} \approx \frac{34}{n} \text{ nH.}$

$$L_{\text{stub}} \text{ (10 stubs each side)} \sim 0.35 \text{ nH}$$

Note the stubs were shorter and made a lower inductance connection to the square cross-section rod than in the start gap and bank gap cases.

$$L_{\text{gap body}} \sim \frac{12.6 \times 3}{55} = 0.69 \text{ nH,}$$

giving $L_{\text{out}} \approx 1.0 \text{ nH.}$

The impedance of the line as seen by the sharpening gap ~ 0.65 plus 0.1 load resistance ~ 0.75 ohms. For the multichannel calculations ωL_{out} has to be added, where $\omega \sim 3 \times 10^8$, ie $Z_{\text{eff}} \sim 1.05$ ohms.

Thus $\tau_L = \frac{34}{1.05n} = \frac{32}{n} \text{ ns.}$

The transit time is $\frac{55}{30}$ ns = 1.8 ns

and the $0.1 \tau_L$ and $0.8 \tau_{trans}$ can be combined to give $4.7/n$ ns.

Using the breakdown field derived from the peak to peak voltage measured, the resistive phase can be obtained and is

p (psig)	τ_R (ns)
0	$12.3/n^{1/3}$
14 1/2	$9.3/n^{1/3}$
22	$8.3/n^{1/3}$

Using these values, Table V can be calculated.

TABLE V (Times in ns)

n	$0.1 \tau_L + 0.8 \tau_{trans}$	$0.1 \tau_R$			ΔT		
		p = 0	14 1/2	22	p = 0	14 1/2	22
10	.47	.57	.43	.36	1.04	.90	.83
20	.23	.46	.34	.31	.69	.57	.54
30	.16	.39	.30	.26	.55	.46	.42
40	.12	.36	.27	.24	.48	.39	.36
50	.10	.33	.25	.22	.43	.35	.32

Now the values of T and σ are required. The slope of the voltage waveform was obtained from the records and for the optimum operating conditions was about 40 ns for each pressure. For other values of p_2 this changes, of course, getting larger the greater the pressure is. The estimation of σ is unfortunately not very good because of the variation of gap length, which was up to 3 per cent in the sharpening gap. Judging from the distribution of the bald patches, the sparks only occurred where this was more like 2 per cent. With something like 40 channels this corresponds to a span of some 5σ , ie $\sigma \sim 0.4$ per cent due to gap variation. The intrinsic scatter from the MC note is about 0.15 per cent for a $t_{eff} \sim 15$ ns. Thus

$\sigma \sim 0.55$ per cent, rather uncertainly. I realise that if the distributions are Gaussian, the straight addition of the two σ 's is not valid, but if the distribution is otherwise (as it may well be), straight addition could apply. However, worries about this are overwhelmed by the basic assumptions as to the effective scatter of the gap width.

Using the above values

$$2 T \sigma \sim 0.45 \text{ ns}$$

and from Table V the expected number of channels is in the range of 30, decreasing slightly with pressure. The numerical agreement here is, again, rather fortuitous and not to be taken very seriously: however, it is obviously in the right ball park. Moreover, it shows that if the gap had been better constructed (a maximum difference in spacing of some 1 per cent with a σ of the order of 0.2 per cent of the gap length), many more channels would have resulted. Again, if the start gap had been made twice as wide, T would have been considerably shorter and again more channels would have resulted. Indeed, so many that the impedance feeding each channel would have risen beyond the range of validity of the relations used in the MC note. However, it would be expected that at least 100 channels would have been obtained with the improvements mentioned above.

The calculated rise times of the pulse from the sharpening gap for the assumed optimum conditions are given in Table VI.

TABLE VI

P_1 (psig)	P_2 (psig)	N_2	L_{gap} (nh)	T_L (ns)	T_R (ns)	T_{tot} (ns)
0	20	40	1.8	2.4	3.6	6.0
14 1/2	30	37	1.9	2.5	2.9	5.4
22	40	32	2.0	2.6	2.5	5.1

With the suggested improvements, the calculated rise time would be under 3.7 ns. This could be decreased further by reducing the edge plane separation and running at higher gas pressures: however, this could not be done very much.

Table VI shows that the rise time is improving as the pressure is increased and in the later series of shots this was done, as the system was operated at higher voltages.

A second point that the calculations show is that providing the sharpening gap has the same wave front impressed upon it along its length, the standard deviation of the output wave will be around $+ 1/2$ ns and with improvement this will probably halve. Indeed it may well do better than this, because with 20 channels in a length equal to the distance from start gap to load (10 cm), averaging will smooth the ripple down to something below 0.1 ns. However, there will be large-scale changes across the wave front on top of these small scale variations, caused by possible variations in amplitude across the width of the line in the wave hitting the sharpening gap. These are briefly mentioned again towards the end of this note.

OUTPUT PULSE

The output pulse was monitored by attaching the 'scope cable directly across the resistors that formed the nominal 0.1 ohm load. There is some small inductance in this load and this was cancelled out to the first order by arranging the length of the stripped inner of coax to have an inductance such that the integrating effect of this was approximately equal to the inductive spike time of the load resistor array.

Figure 17 gives a tracing of a typical output pulse. This is shown in more detail in Figure 19. The observed waveform from the 'scope has to be corrected for the 'scope response. This is given in Figure 18. Most of the late rise time is in the delay cable, which allows the 'scope to trip before the signal is displayed and hence accounts for the shape of the 'scope response. Shown in Figure 18 is the calculated response to a step waveform and also the observed one, which was measured with a strip line generator switched by a tin tack driven solid gap. The agreement is amply good enough for the present purposes.

Figure 19 also gives the pulse front corrected for the 'scope response. In addition to decreasing the rise time, the correction for the 'scope response also raises the peak voltage that an infinite bandwidth 'scope would have measured. Once again the measured two-way transit time is longer than the 12 ns that the FHS beyond the load represented. This is, as before, due to the inductance of the sharpening gap and also possibly to some integration of the pulse when it bounces off the open circuit end of the RHS line. At these voltages corona conditions must change over a centimetre or two at the end of the line and this represents a small integration effect.

The maximum rise time for the record shown in Figure 19, after correction for the 'scope response, is 4.7 ns (maximum slope). The conditions for the record were $p_1 = 22$ and $p_2 = 29$, a bit below the optimum, but one which gives a faster rise than that calculated in Table VI, which gives the conditions for maximum peak current. Indeed, because of the faster rate of

change of voltage at the sharpening gap breakdown point, the mean field was 10 per cent up on that used for the Table V and Table VI calculations. This reduces the resistive phase by 13 per cent, giving a calculated rise time of 4.8 ns. Again the agreement is too good, but I assure you, unfiddled.

OUTPUT CURRENT

As was mentioned earlier, the smaller 10 ohm resistors were used to make the nominal 0.1 ohm. When originally assembled, the resistance was about 10.1 Ω for each resistor. However, after the next series of high voltage shots to be described, a representative series of resistors was measured and found to have dropped their average DC value to 9.2 Ω . The energy dissipated in the 0.1 Ω resistor assembly during the high level shots can be roughly calculated. The peak i was 110 kA and the duration of the fast pulse was effectively about 20 ns. However it was followed by a chain of further pulses equivalent to a total of about 6 pulses (including the bank ringing current as well), giving an effective duration at full power of about 120 ns. Thus the energy dissipated for resistance would have been about 1.4 joules. The volume of carbon composite is a little smaller in the new resistors, so this might be equivalent to about 2 joules per resistor, which would not be expected to have been enough to produce a significant DC change of resistance in the old resistors. However, the old big resistors are mechanically enclosed in a ceramic body which supports them against any weak shocks caused by the heating. Other tests on USA resistors showed that they suffered DC resistance changes at levels of a joule a resistor even though the volumes of the resistor carbon composite material were similar. Also all the tests we have done show that when a DC change of about 10 per cent drop occurs in a few pulses, there is an additional 20 to 30 per cent drop in resistance during the pulse. This is caused by the fact that the current densities in the actual carbon filaments are very much greater than those obtained by taking the average cross-section of the composition rod, and heating and shock expansion cause a reduction of the resistance of these filaments. Anyway, as can be seen from Table VII, there is a progressive reduction of measured voltage across the carbon resistor loads compared with the voltage across the sharpening gap at closure time. The values agree well at low current levels but fall as the voltage and current are raised.

It is very difficult to see any reason why the system should not show a linear (or, rather, slightly super linear) relation between volts in the sharpening gap and the output current. The super linearity would be expected, because the rise time of the gap improves as the voltage is raised. Thus it is assumed that the load resistors are dropping their pulsed resistance, and the data obtained on other resistors is assumed to apply to this type. Thus in addition to the observed DC drop of the load resistor to 0.092 ohms, there would be a further pulse

drop while the pulse volts were on, amounting to an extra 20 per cent or so at the top voltages recorded during the final current test shots. Obviously the best solution would have been to have repeated the measurements with a linear current monitor; however, as this was being planned, the programme had to be stopped. In fact, in the absence of, say, 150 of the old 10 Ω 1W resistors, it was not easy to make such a resistance with an adequately low inductance and an adequate heat-absorbing capacity. The one planned would have been a nichrome sheet one. Alternatively, and perhaps additionally, an integrated B dot coil would have been employed.

However, Table VII summarises the data obtained.

TABLE VII

Bank Volts (kV)	p ₁ (psig)	p ₂ (psig)	Load (kV)	Corrected 'scope Rise Time	Estimated Load R Ω	i (kA)	i S/C	V _{p-p} (kV)	i S/C Calc. (kA)
37	0	20	4.7	5.2	.087	60	68	44	68
45	15	30	5.5	6.0	.083	72	81	57	88
56	22	40	6.7	7.3	.078	93	104	70	107
64	32	54	7.3	7.9	.073	108	120	83	127

Table VII lists the operating conditions for the series of shots and then gives the voltage measured on the 'scope. This has to be corrected for the 'scope response (+ 8 per cent). The next column gives the estimated pulse resistance of the load based on a DC value of 0.092 ohms. From this a measured current is derived and then, using a total line impedance, the short circuit current is derived, taking out the load resistance. The next to last column lists the voltage swing (measured on the records) from the level at which the start gap had fired to when the sharpening gap operated. The final column gives an independently determined short circuit current based on this and the calculated likely line impedance of 0.65 ohms. As can be seen, the line impedance determined current is above that estimated from the load resistance measurements, but the agreement is quite good. Using the average values of the peak current, the output of the line at 64 kV on the bank would have been about 123 kA into a short circuit. For the bottom line of shots, the start gap was operating at 65 kV. A few shots were done at 70 kV operation of the start gap, with no signs of breakdown and, indeed, at no time did the line track; these shots would have corresponded to 135 kA short circuit current.

With a twice width start gap, the overswing after the operation of the start gap would have been 15 to 20 per cent higher, giving good sharpening gap operation at 90 kV, with 65 kV on the bank, which again would give short circuit currents of about 135 kA. Thus there is a very reasonable expectation that a start gap rebuilt line, or, at slightly higher voltage of operation, a line of 60 cm wide, would give 135 kA. Thus it is expected that the 140 cm wide line would be expected to run at 300 kA and possibly a bit higher.

The system was found to be easy to fire and reproducible in its characteristics, and could easily be fired once a minute, although the life tests which were planned unfortunately were not carried out. However, the start gap and LHS line had about 2000 firings at between 35 and 60 kV on them, and the full system some 1000 shots, mostly in the same voltage range.

This concludes the summary of some of the data obtained with the 60 cm wide experimental line. Before going on to the suggested 140 cm wide system, it may be worth briefly mentioning the effort and cost involved in the 60 cm experiments. The work was done by myself and a vacation student (Ian Grimson), and while it took about 7 calendar weeks, only some 6 weeks' time was actually available during the period. The total construction time for the bank and the lines was about 3 weeks. During this time essentially everything was made, excluding the bank gap which happened to be around. However, the gas pressure and flow gear had to be assembled and if this were excluded, the time to make all of the bank plus lines, including all the gaps, would have been the 3 weeks. The power pack was to hand, as were the untabbed condensers. The remaining 3 weeks were roughly split between monitoring the performance of the system, including running it up to the maximum volts at which it was tested, and in making the measurements reported in the edge plane note. However, it must be stressed that we knew pretty well what we were doing and it would take someone inexperienced in the area considerably longer than this.

As regards costs, the local condensers (which were to hand and were, of course, reused afterwards) cost about £200 and the cost of the rest of the materials in the bank and line would add about another £200. If we had had to build a power pack (which we do with components ratted from a component store on site, or obtained secondhand), it would have cost us another £200 or so.

The only engineering effort used was in cutting the brass sheet accurately to the widths required for the edge plane gaps and in making the brass fittings for the pressure seals for the start gap. The sharpening gap seals were made by us.

To make the larger line discussed below would cost at most £300 in materials, I estimate, excluding the power pack and condensers,

and would take us now, with what we know, about the same time as the 60 cm line did. A bit more time would be needed to do the monitoring, to ensure the long wave flatness of the wave front beyond the sharpening gap, but obviously we would not repeat the extensive series of measurements with different gases in the edge plane gaps. So, roughly, I would expect to spend about 10 man weeks to make and diagnose the operation of the full line. However, again it must be stressed that we would have all the materials to hand and would know pretty exactly what we were doing, so the time scale suggested applies only to us.

140 CM WIDE SYSTEM

BANK

There are two modifications I would suggest be made to the basic bank we slung together for the 60 cm wide line tests. These are to go plus and minus for the charging volts and also to split the bank either side of the uniform field DC switch. This latter change reduces the inductance of the switch and also reduces the performance required from the condensers.

With regard to the plus and minus charging, this eases any tracking problems across the gap (not that we had any trouble here) and also for the price of another set of rectifiers doubles the output of a power pack. In building our power packs, most of the cost is in variac, transformer, etc. and a + 35 kV unit is significantly easier and cheaper to build than a 70 kV one. There is no need, of course, for the power pack to be stabilised, or anything fancy, and it only needs to supply a milliamp or two of current to charge adequately quickly, as far as I can see.

Figure 21 shows a drawing of the gap and a sketch of the condensers and output lines. The suggested gap would still use a 2" OD perspex tube and have the brass rod and gap dimensions given for the 60 cm line bank gap. However, the rods would be made 10" long and be bowed up slightly over the centre 4" or so, so that the breakdowns occurred in the central region. I would suggest 6 connections to either rail, but you could get away with 5 if you wanted to. The inductance of such a rail gap, fed from both sides, would then be approximately

$$L_{\text{spark}} \sim 4 \text{ nH}$$

$$L_{\text{feed}} \text{ (based on a 16 cm width)} \approx 5.3 \text{ nH}$$

$$L_{\text{stubs}} \sim 1 \text{ nH}$$

$$L_{\text{gap body}} \sim \frac{12.6 \times 14}{16} \times \frac{1}{2} \sim 5.5 \text{ nH.}$$

The reason that 16 cm width is taken is that this makes the $L_{\text{feed}} \sim L_{\text{gap body}}$. However, it pays to make the rail and the external copper sheets wider than this, as some current flows out there and so reduces the inductance below that calculated in the above simplistic way. This gives a total gap inductance, fed from both sides, of about 16 nH, or maybe a bit less.

If the condensers have an inductance (suitably tagged, of course) of 10 nH each, the four capacitors add 10 nH, and if the two "inductor" feeds are arranged to have an inductance each of 20 nH, this gives an all up inductance around 40 nH. If you can't get four 10 nH, 35 kV capacitors, then you surely can get eight 20 nH capacitors and put them in in pairs. This may be necessary anyway, to get the required current rating (dealt with below).

The total line capacity would be about 120 nF and I would suggest a total bank capacity of 500 nF, to give you a bit more ringing gain than we had. Thus each capacitor (if you use 4) will need to be 0.5 microfarad and I would suggest you might get 40 kV condensers, to have a bit in hand. So a suggested requirement for the capacitors is four off 40 kV 0.5 microfarad, each of whose inductance is 10 nH or less and whose ohmic resistance should be less than 40 milliohms (not a very restrictive requirement). A further requirement for the capacitors is that they should be capable of giving 40 kiloamps peak current each (reached after the start gap closes) and they should have a good life with something like 60 per cent reversal. These requirements should be obtainable, but if they are difficult they can be halved (or doubled, depending on what parameter it is), by using eight capacitors.

In the charging circuit the lumped inductance will be 40 nH and the C_{eff} about 100 nF. This gives a $\sqrt{LC_{\text{eff}}}$ of about 63 ns, a little longer than that used in the above tests. However, I do not feel the increase will be important. However, the ringing gain should be significantly better than in our system and at 30 kV I reckon (if the wide lines are assembled no worse than ours) that you should get a peak gain of around 1.30, compared with 1.13. This should enable the system to work at rather less volts on the bank, or drive the line higher, or fire a bit earlier in the waveform, before peak and win back the difference between 63 and 50 ns in the charging time, if this proves necessary.

As is shown in Figure 21, resistor chains are placed across the two outputs, in order to discharge the system reasonably quickly in the event of the start gap not going (very unlikely at high volts). These should have a value of about 40 ohms each and be

made of chains of 8 resistors in series and absorb about 500 joules each, at worst. If you were using our old 1 watt resistors, you would need about 100 totally on each side.

If the system is plus and minus charged, the flux excluder on either side of the gap can be earthed via a 10 kilohm sort of resistor chain and the earth plane can extend past the capacitors, as is shown in the sketch. This helps to isolate the HT tabs on the condensers from each other and makes the tracking problem a + 35 kV not a 70 kV one.

The bank stores some 1.2 kilojoules at 70 kV and therefore is a dangerous one if contact is made with the DC connections (you can kill yourself with this energy). However, all the mylar wrapping tends to make it very difficult to get at the DC but an automatic dump system should be arranged to short out the bank and power pack when anyone approaches it. The energy that can be collected from the lines when these are operating is much less. The human body is about 200 ohms at this voltage and frequency and in normal operation at like 70 kV the volts are around for about 1 microsecond, so that it is possible to get about 30 joules from it. This will not kill anyone, but it would be a nasty shock which one would not wish to repeat.

The feeds to the bank, which also act as the tuning inductors, need to be about 20 nH each and hence want to be of width about half their length, when they are separated by 1 cm. Figure 22 shows a possible location of the bank and the feed points to the line. The output to the RHS line needs to be split in two, as shown, in order to feed the 10 cm of line between the output gap and the gas cell. In our experiments, the 0.1 ohm load resistor charged this capacity adequately quickly, but it will be necessary to balance this line too, to keep the prepulse on the gas cell down to whatever is necessary (presumably a few kV prepulse can be tolerated, especially as it is only on for about 100 ns).

THE LINES

The construction of these is as for the 60 cm line. The main differences are now that the sharpening gap is slanted and that the start gap is wider. Figure 22 gives a suggested arrangement. Although I would expect the rise time of the output from the start gap to be better than in our tests, I would not rely upon this much, hence the lines are about 1 metre longer overall than the system we made. Anyone building the wide line might chance their arm and decrease this some, but if the pulse rise time from the start gap is no better than in our tests, they will then have to increase the thickness of the LHS line by using two sheets of polythene so as to raise the impedance at the switch and regain the rise time required.

Difficulty may be experienced in getting wide enough sheets of mylar; however, if the slimmer sheets can be joined by overlapping about 2" and twinsticking over, say, an inch, then they should be OK. Such joints should be staggered across the width. Hopefully it will be possible to get the 1/32" polythene in a wide enough roll, otherwise, rather less desirably, this can be overlapped. Clean the sheets with acetone or other solvent, otherwise the twinstick won't, and put a double layer of twinstick, i.e. one on each sheet.

START GAP

I would make the rails of the start gap about 70 cm long, with the perspex body about 3-1/2 feet wide. The scaled up length of the rails of our gap would only be some 35 cm long over the uniform field part, so such a length should usefully reduce the gap's inductance. I would also decrease the gap from 0.72 cm to about 0.6 cm. This raises the pressure in it and avoids operation near atmospheric pressure, where the jitter is rather large (see edge plane note). It should perhaps be considered whether to make the stud contacts of the edge a bit more accessible, by unflapping the mylar over them, so that the edge can be removed for resharpening, should this become necessary after a lot of shots, but normally the mylar overwrap should cover the contact points. Because of the greater width of the start gap, the side angle of taper into the line is not very much bigger than in the 60 cm line, but again the line insulation should be reduced in thickness modestly, as you approach the gap, in order to keep an approximately constant line impedance.

SHARPENING GAP

This will be about 2 metres long and inclined at roughly 45° to the axis of the line. I think the spacing should probably be kept at 0.6 cm or thereabouts. It would probably be simple to make the 1/4" OD rail in one piece, but the knife edge probably should be made in two bits with the ends rounded where they nearly join in the middle. The perspex tube we get has a very good constancy of diameter and is cast, which is probably better than extruded tube. However, if there is a slight taper in its diameter, packing behind the 1/4" rod can be used to maintain an adequately constant spacing. Because the start gap will have a better rise time, in all probability, and can certainly be better made, it is likely to have some 400 channels in it. It is, of course, to be slanted and hence a 55 cm length of it will be feeding not 0.65 ohms but more like an ohm. Using these numbers, it is calculated that for p_2 pressures greater than 40 psig, the rise time on the far side of the sharpening gap should be 3 ns, falling a little more with increasing pressure.

The small wavelength ripple should be less than 0.1 ns, but if there is a change of amplitude across the front of the pulse

moving up the line, then there will be a time difference across the width, after the sharpening gap. Thus if there were a 5 per cent difference in amplitude of the pulse arriving at the sharpening gap, the time difference one side to the other would be of the order of 1 ns for the expected value of T at firing time of about 20 ns. Such a difference could come about as a second order effect of their being a voltage gradient down and across the line from the feed point. Alternatively the extra distance the wave has to travel to reach the late end of the sharpening gap might conceivably produce a few per cent difference. However, if this were to happen, it could be corrected by changing the angle that the sharpening gap makes to the axis of the line. In order to check whether this is necessary, the time of arrival of the pulse beyond the sharpening gap must be measured across its width. This measurement needs to be made to a fraction of an ns and is quite a challenging one, as it has probably to be made on a single pulse. It is possible that a signal taken from the start gap can be used to trip the 'scope with adequate constancy, so as to measure the pulse arrival time at various points across the line on successive shots, but I rather doubt it. If not, the polarity must be measured on a single shot and then mixing the signals from a fixed central point and a variable point across the width would be the best way, I think.

CONCLUDING COMMENTS

I am afraid that by this time most of the readers of this note will be rather tired of its detailed nature, purely apart from its other failings. I wholeheartedly agree with them. On the other hand, anyone who tries to build the 140 cm wide system without previous experience in the modern field of high speed pulse voltages, may wish it was twice as long (some people are masochistically inclined). To them I must apologise for any numerical or other inconsistencies and for all of the things that are either left out or opaquely explained.

The note gives a detailed account of the construction and operation of the test 60 cm wide line and suggests the outline design of a 140 cm line, which is pretty confidently expected to provide a short circuit current of 300 kA rising in about 3 ns. The very best of British luck to anyone who wishes to try.

ACKNOWLEDGMENTS

Ian Grimson very ably assisted me in the construction and testing of the 60 cm wide line and my warmest thanks are extended to him for this help.

I am, as usual, eternally indebted to Mrs. G. V. Horne (or at least until the next note) for her untiring labours in taking my terrible scrawl and turning it faultlessly and quickly into elegant typescript and English. My one real worry is that my

unbelievably awful spelling will one day undermine hers, which is perfect, by some form of contagion.

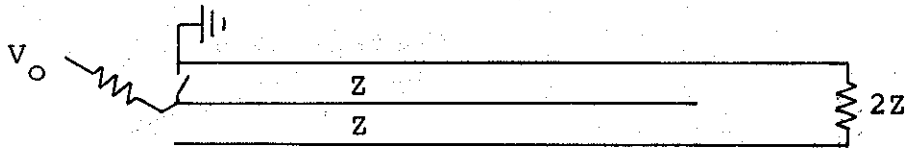

Normal Blumlein circuit

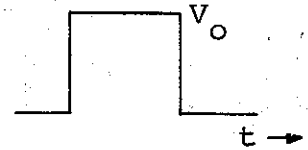

Waveform into matched load $2Z$ ideal switch

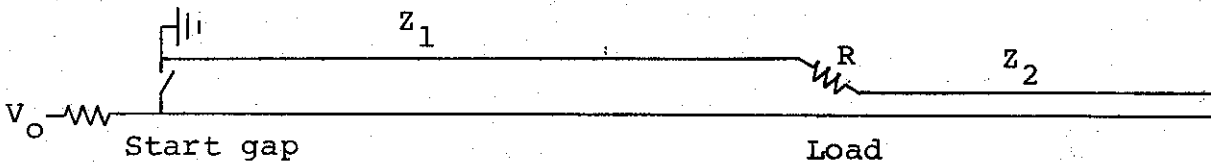

Equivalent circuit first pulse

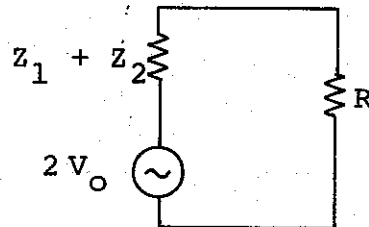

Duration of first pulse ideal switch equal two way transit of shortest line (τ_0)

Blumlein circuit as used

FIGURE 1

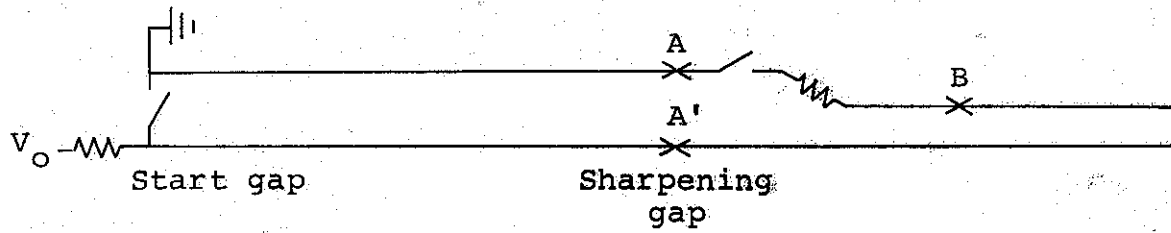

Blumlein with pulse sharpening

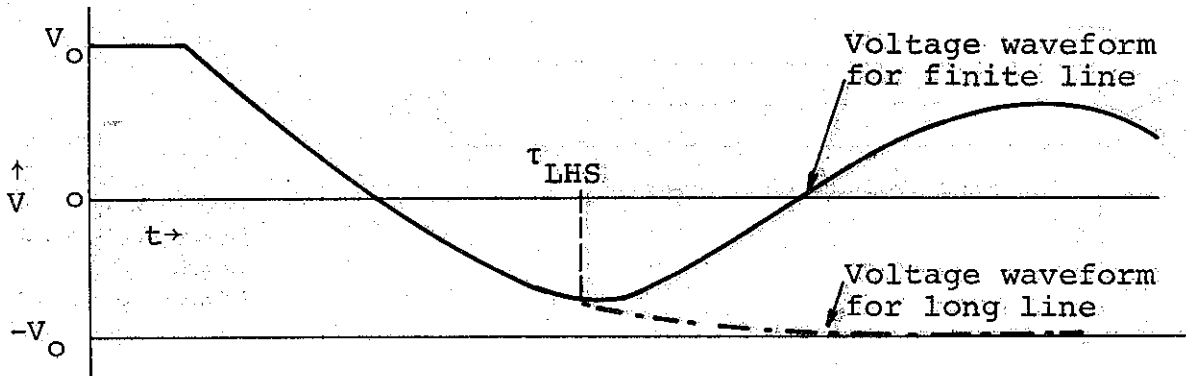

Waveform AA' sharpening gap not operating

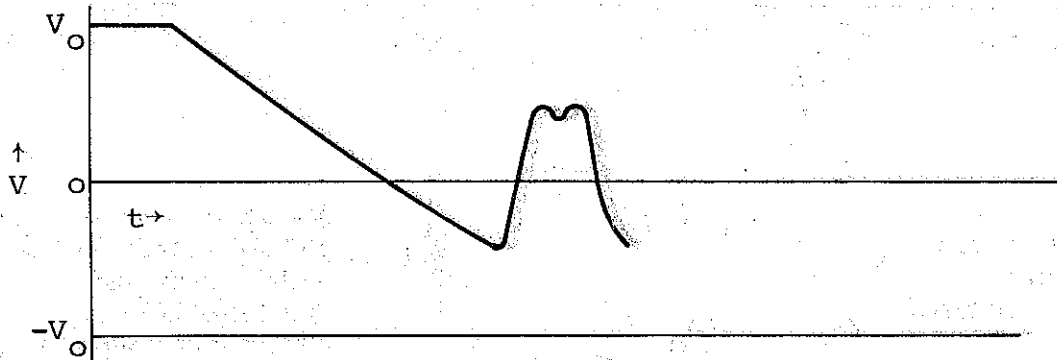

Waveform AA' with sharpening gap operating

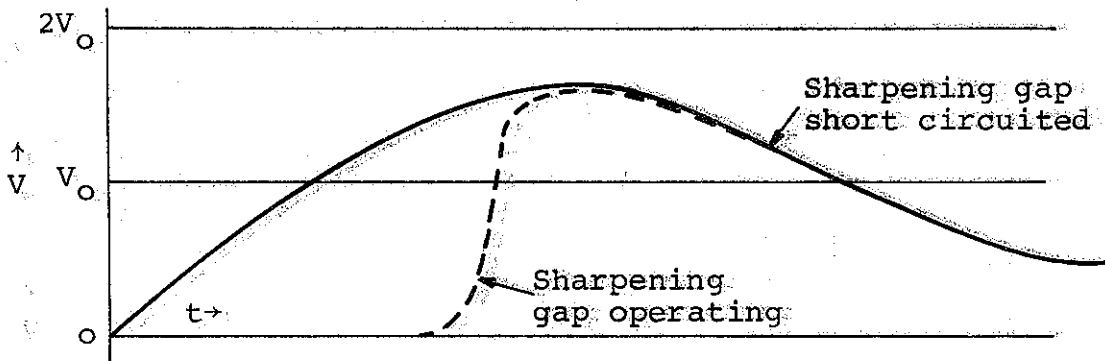

Waveform AB (for $R \gg Z_1 + Z_2$) with & without sharpening gap operating

FIGURE 2

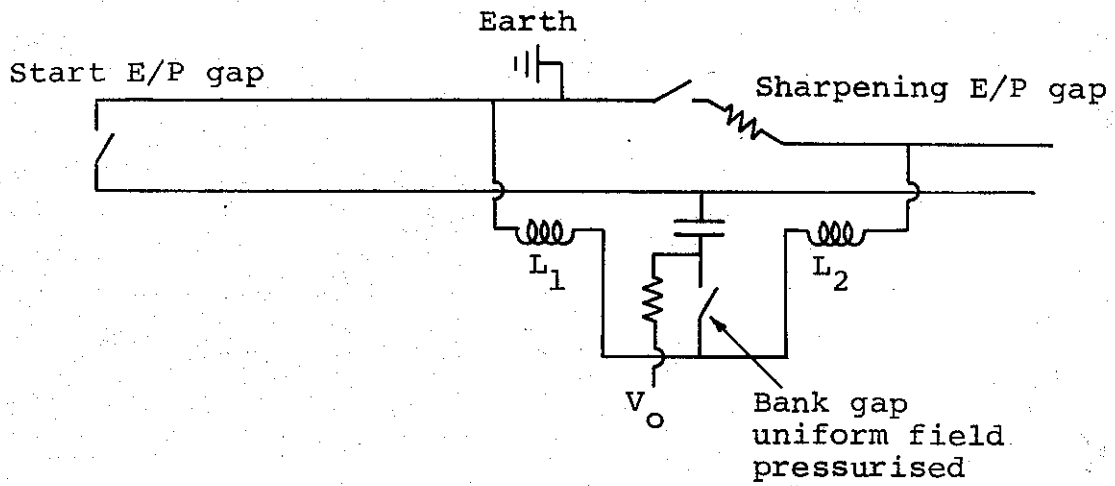

PULSE CHARGED BLUMLEIN FIGURE 3

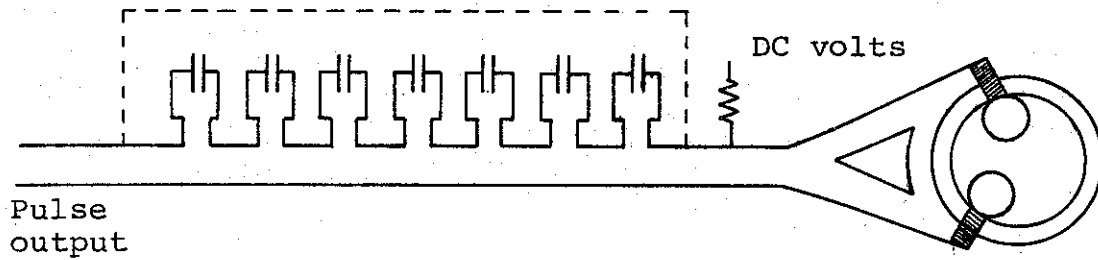

SCHEMATIC OF CONDENSER AND GAP FIGURE 4

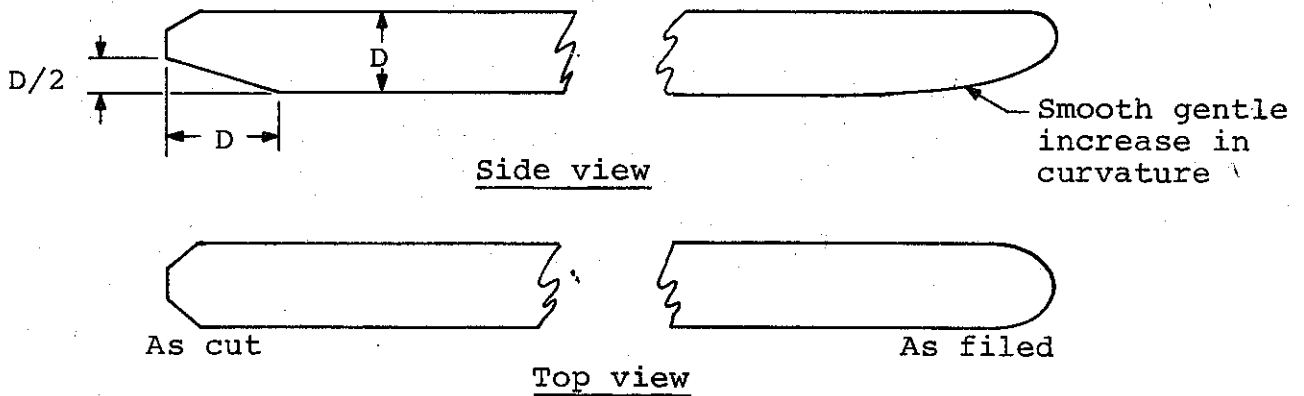

UNIFORM RAIL GAP ELECTRODE SHAPING FIGURE 5

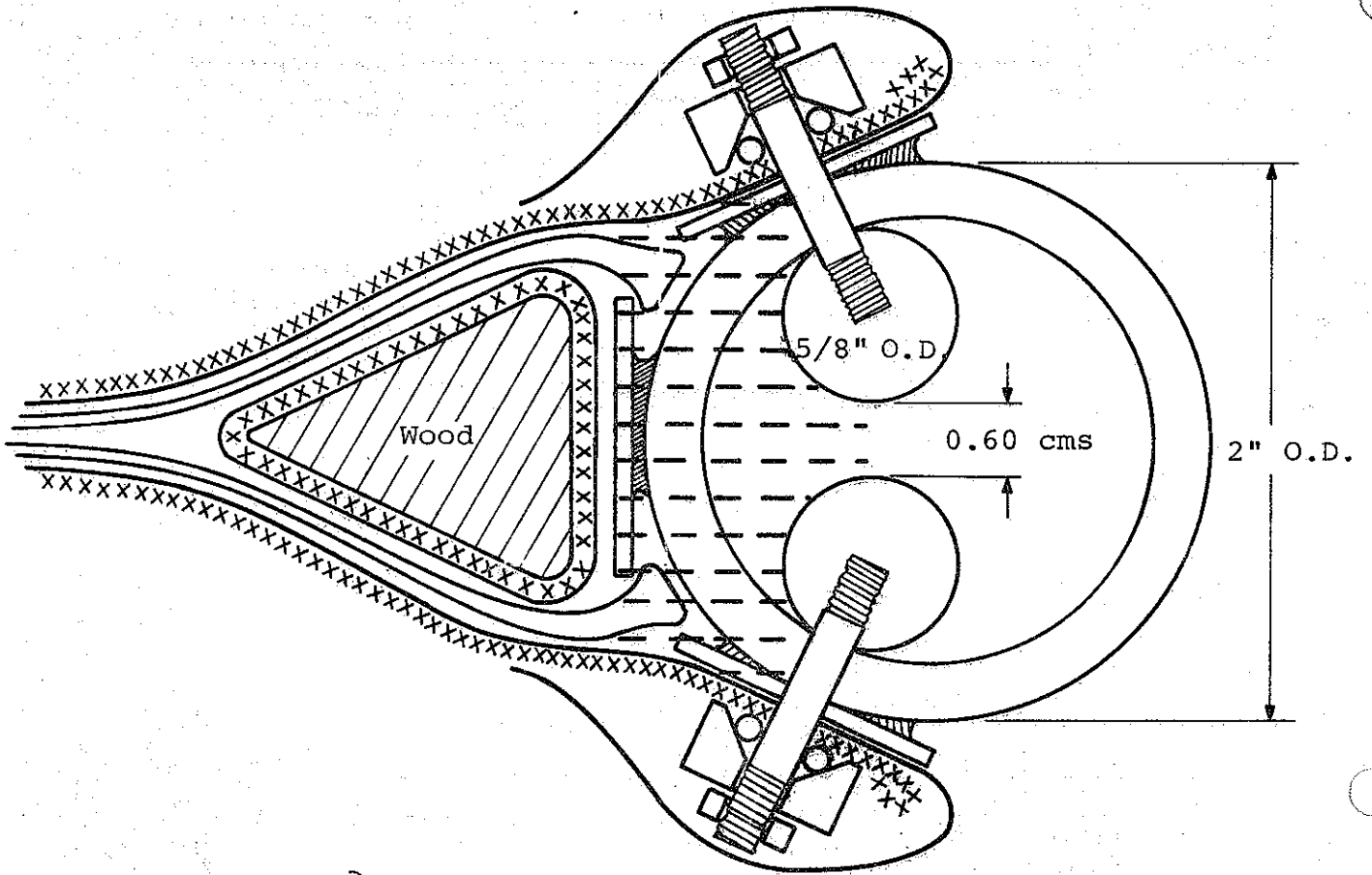

--- } Area for L_{gap} body
 --- }
 --- }

xxxxxxx Copper

———— Mylar most of the sheets shown

 Simplex joint

BANK GAP FIGURE 6

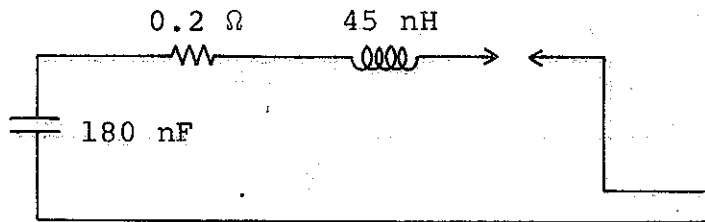

BANK CHARACTERISTICS FIGURE 7

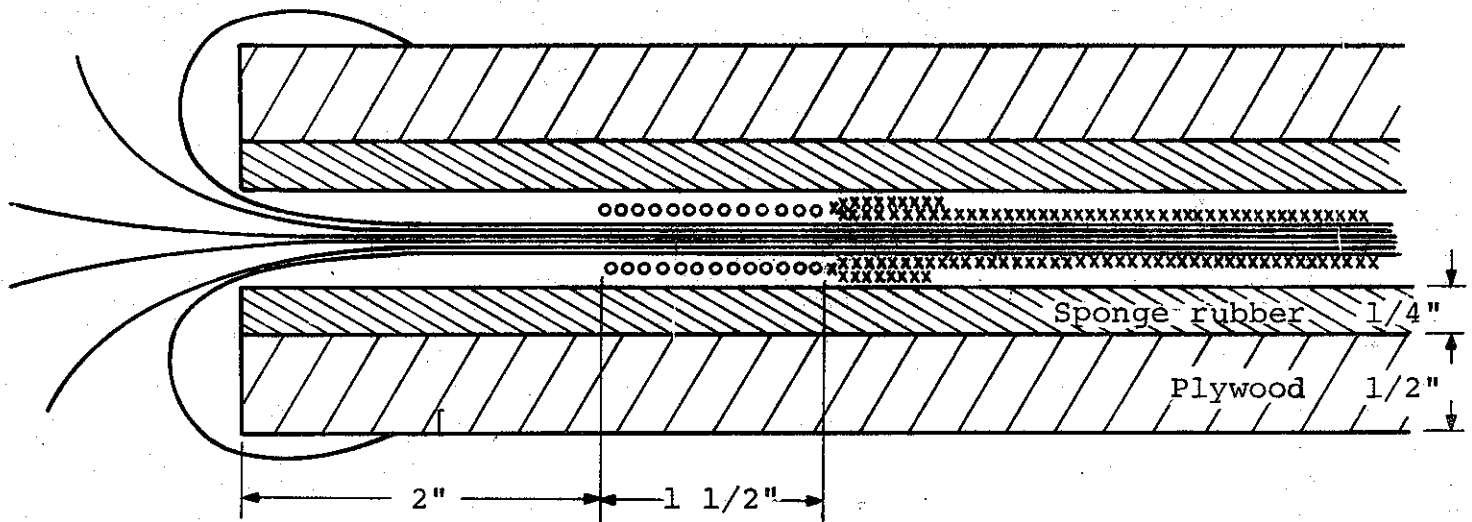

○○○○○○ Blotting or filter paper
 ××××××× Copper
 — Dielectric

Insulation thickness exaggerated

EDGE GRADING OF LINE FIGURE 8

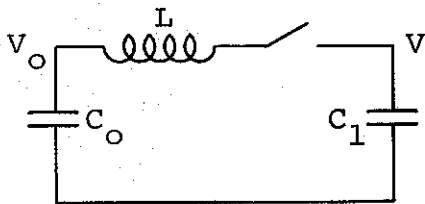

$$\frac{V_{\max}}{V_o} = \frac{2C_o}{C_o + C_1}$$

$$\text{Time constant} = \sqrt{L C_{\text{eff}}}$$

$$C_{\text{eff}} = \frac{C_o C_1}{C_o + C_1}$$

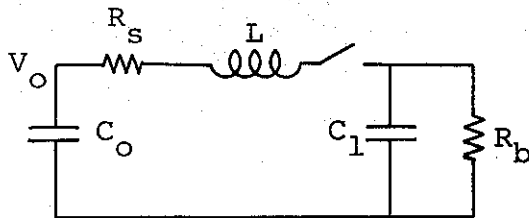

Approx gain (1st peak)

$$\frac{V_{\max}}{V_o} = \frac{C_o}{C_o + C_1} \left(e^{-\pi/2 (R_s / \sqrt{L/C_{\text{eff}}})} + e^{-\pi/2 (\sqrt{L/C_{\text{eff}}}) / R_p} \right)$$

LINE RINGING GAIN FIGURE 9

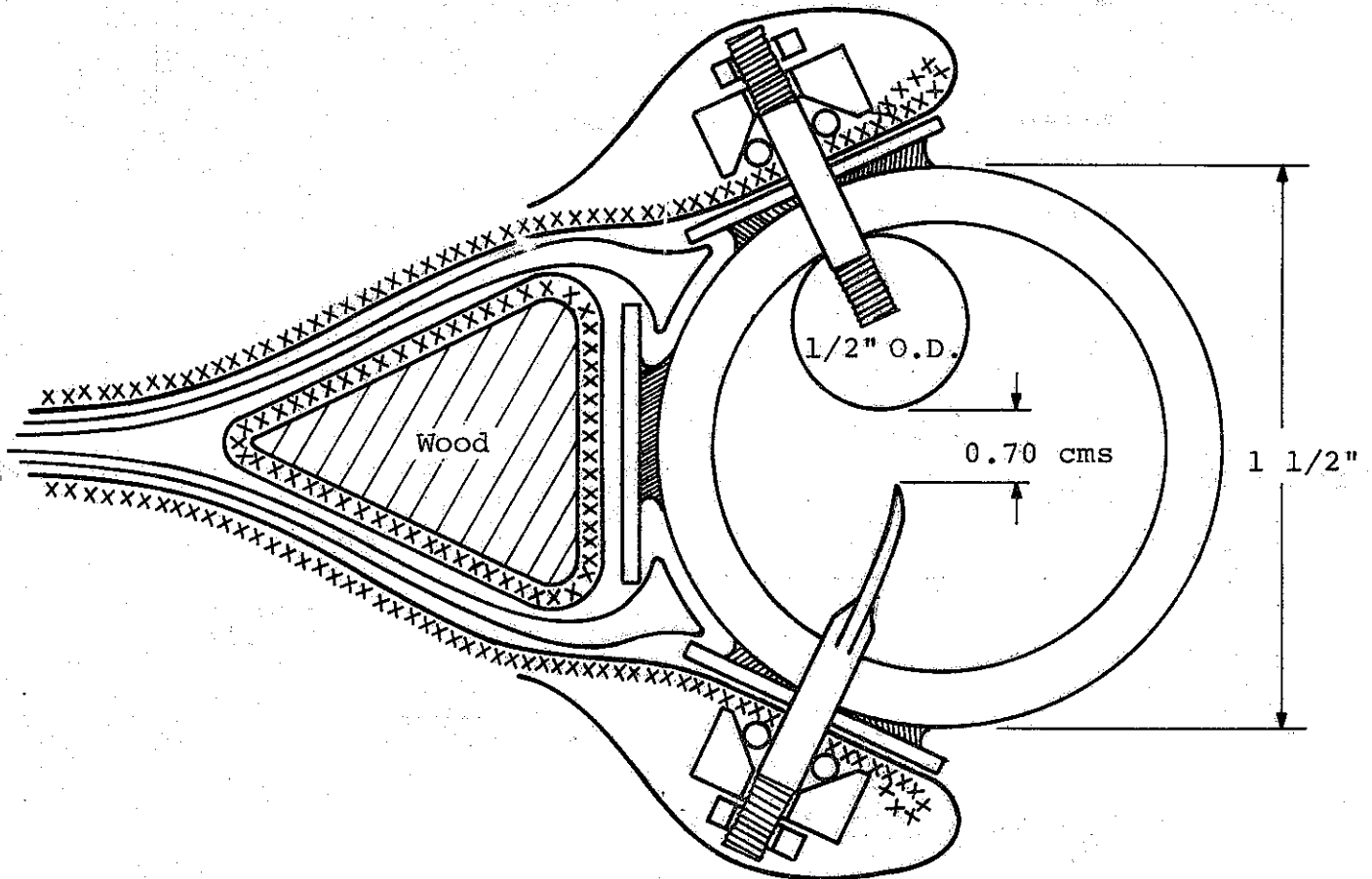

xxxx Copper

Most of the mylar layers are shown
Twin stick used fairly liberally

START EDGE/PLANE GAP FIGURE 10

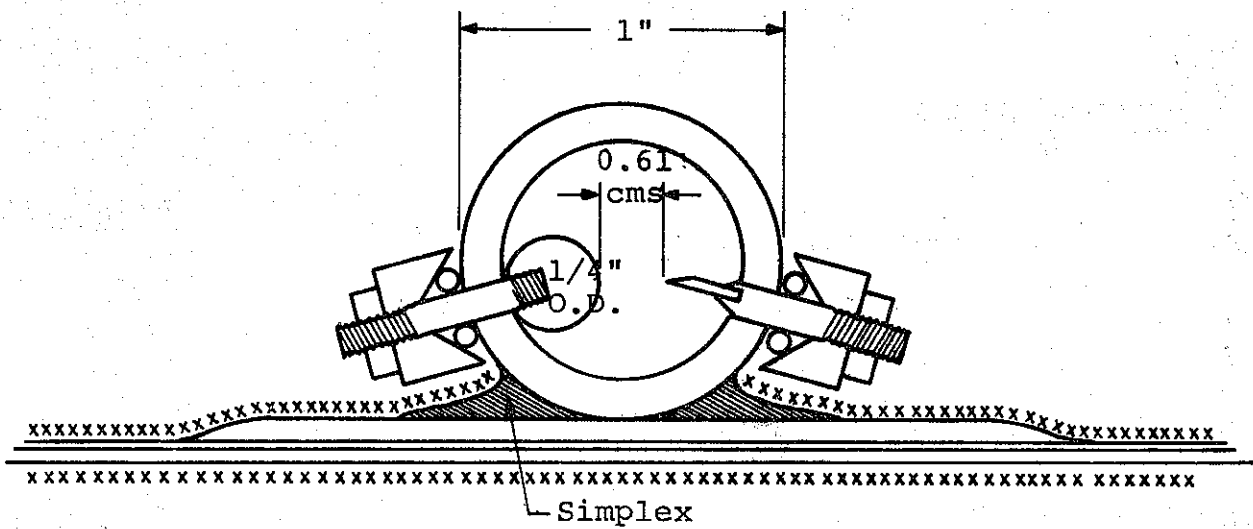

SHARPENING EDGE/PLANE GAP FIGURE 11

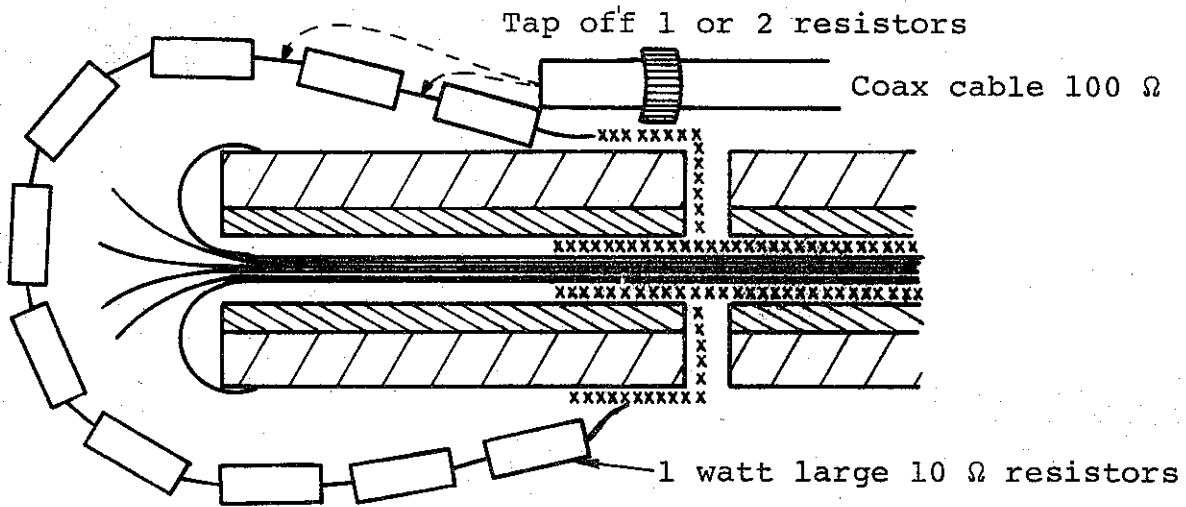

MONITOR CHAIN ATTACHMENT FIGURE 12

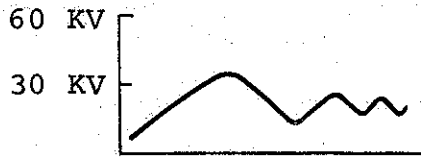

RINGING WAVEFORM

FIGURE 13

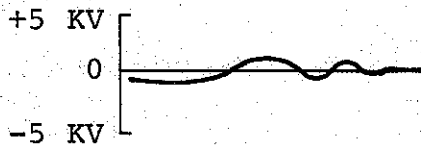
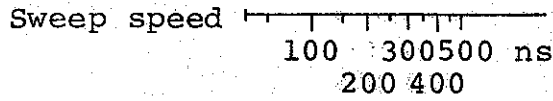

OUT OF BALANCE SIGNAL

FIGURE 14

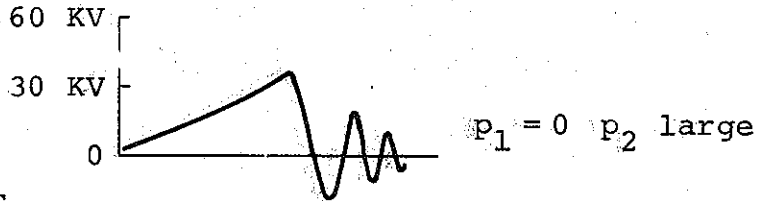

START GAP OPERATING

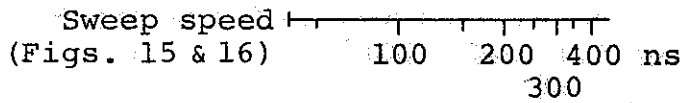
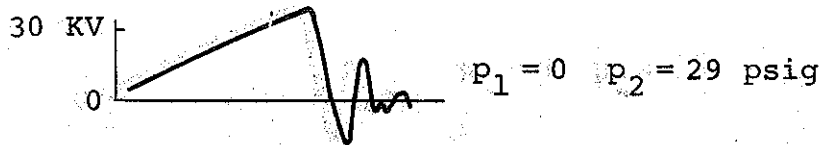
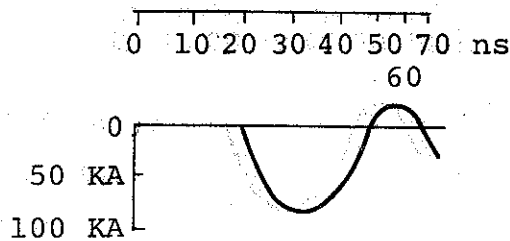

FIGURE 15



START & SHARPENING
GAPS OPERATING

FIGURE 16



Based on
 $R = 0.08 \Omega$

LOAD PULSE

FIGURE 17

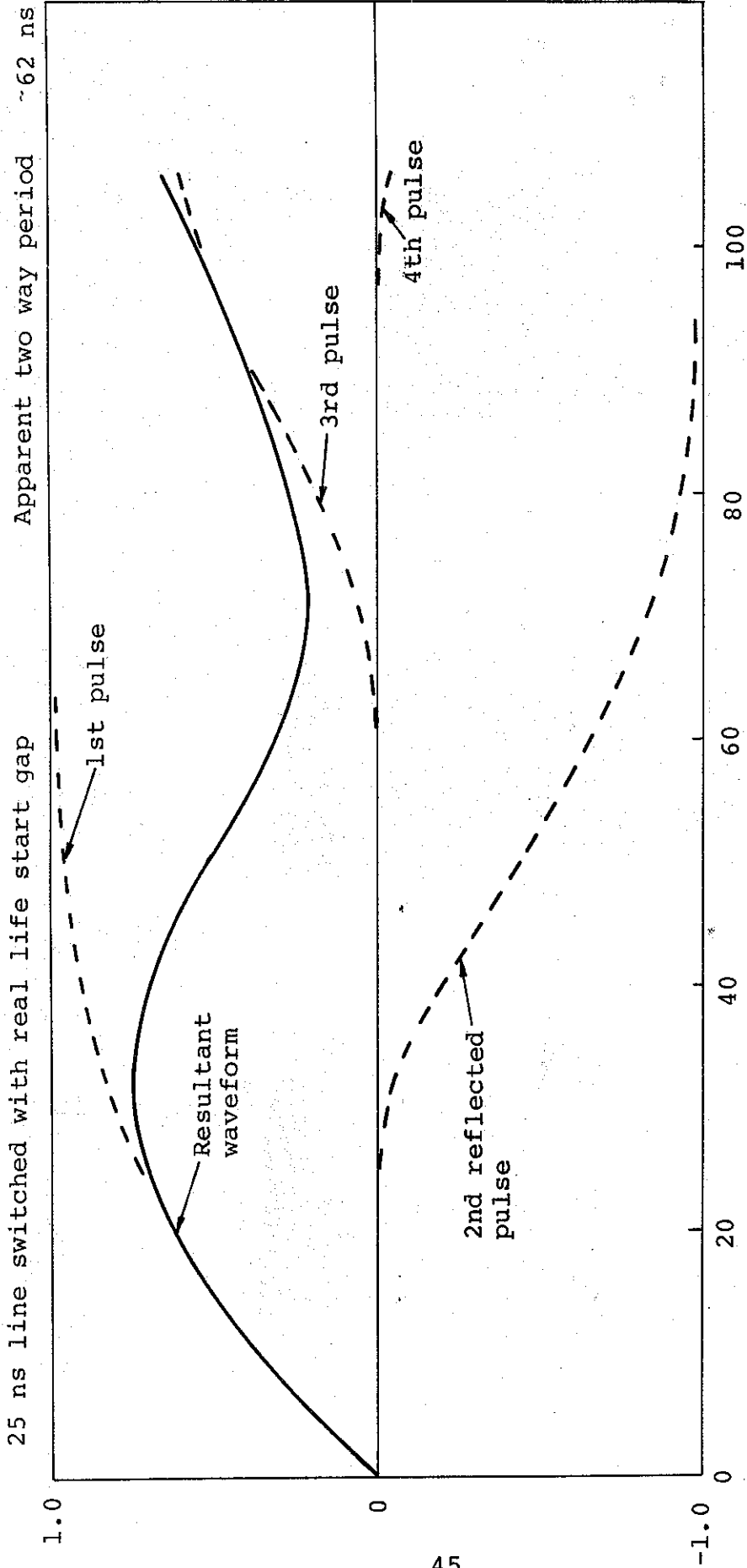
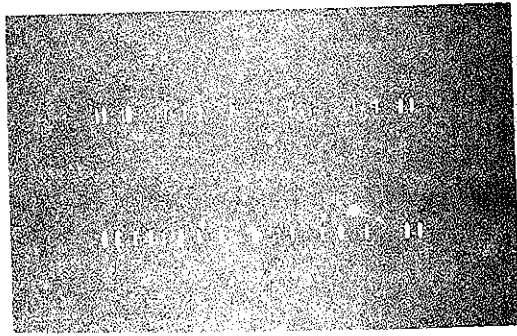
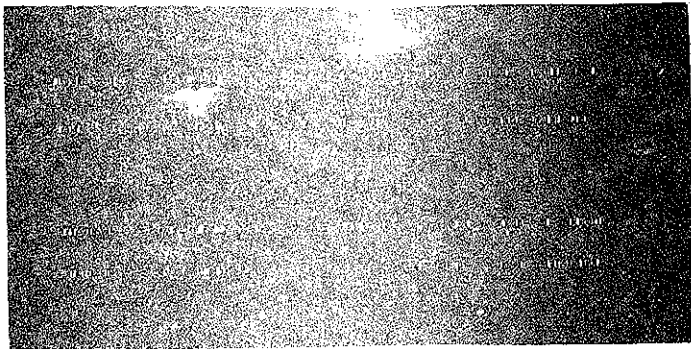

FIGURE 15A



START GAP



$$\left. \begin{array}{l} \text{ } \\ \text{ } \end{array} \right\} p_2 = 27 \text{ } \mu\text{sig}$$

$$\left. \begin{array}{l} \text{ } \\ \text{ } \end{array} \right\} p_2 = 29 \text{ } \mu\text{sig}$$

SHARPENING GAP $p_1 = 14\frac{1}{2} \text{ } \mu\text{sig}$ $V_{\text{BANK}} = 45 \text{ KV}$

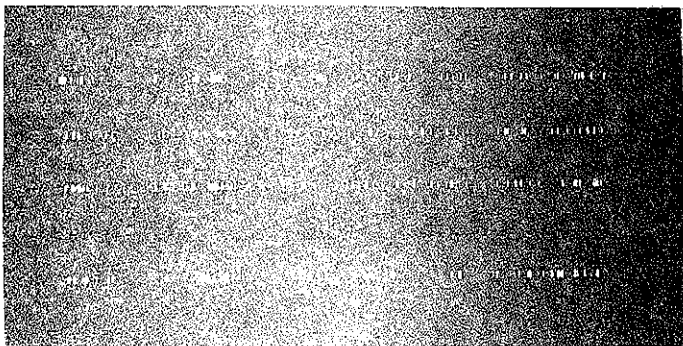

$$\left. \begin{array}{l} \text{ } \\ \text{ } \end{array} \right\} p_2 = 29 \text{ } \mu\text{sig}$$

$$\left. \begin{array}{l} \text{ } \\ \text{ } \end{array} \right\} p_2 = 37 \text{ } \mu\text{sig}$$

SHARPENING GAP $p_1 = 22 \text{ } \mu\text{sig}$ $V_{\text{BANK}} = 56 \text{ KV}$

SCATTER PHOTOGRAPHS FIGURE 16A

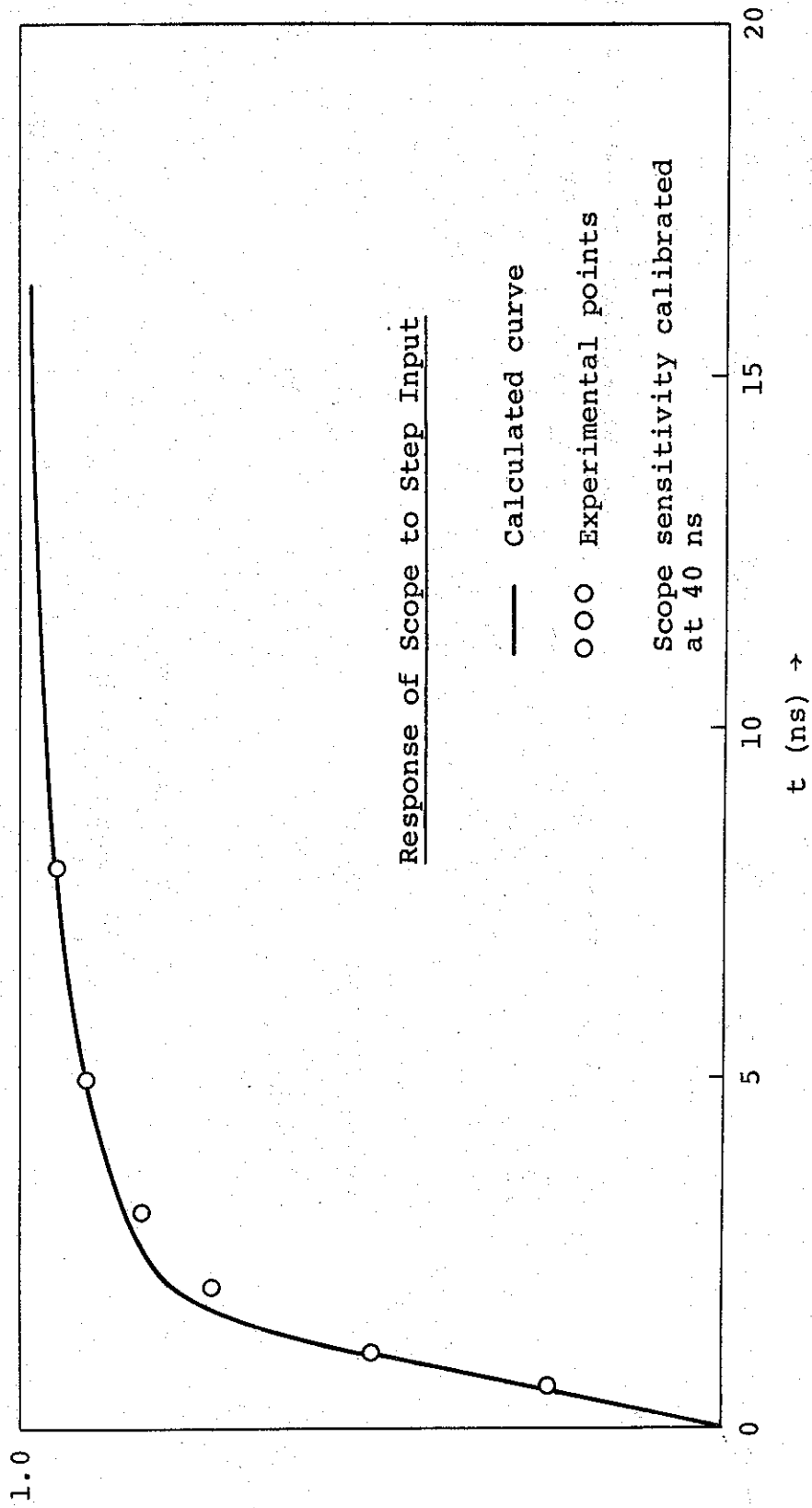

FIGURE 18

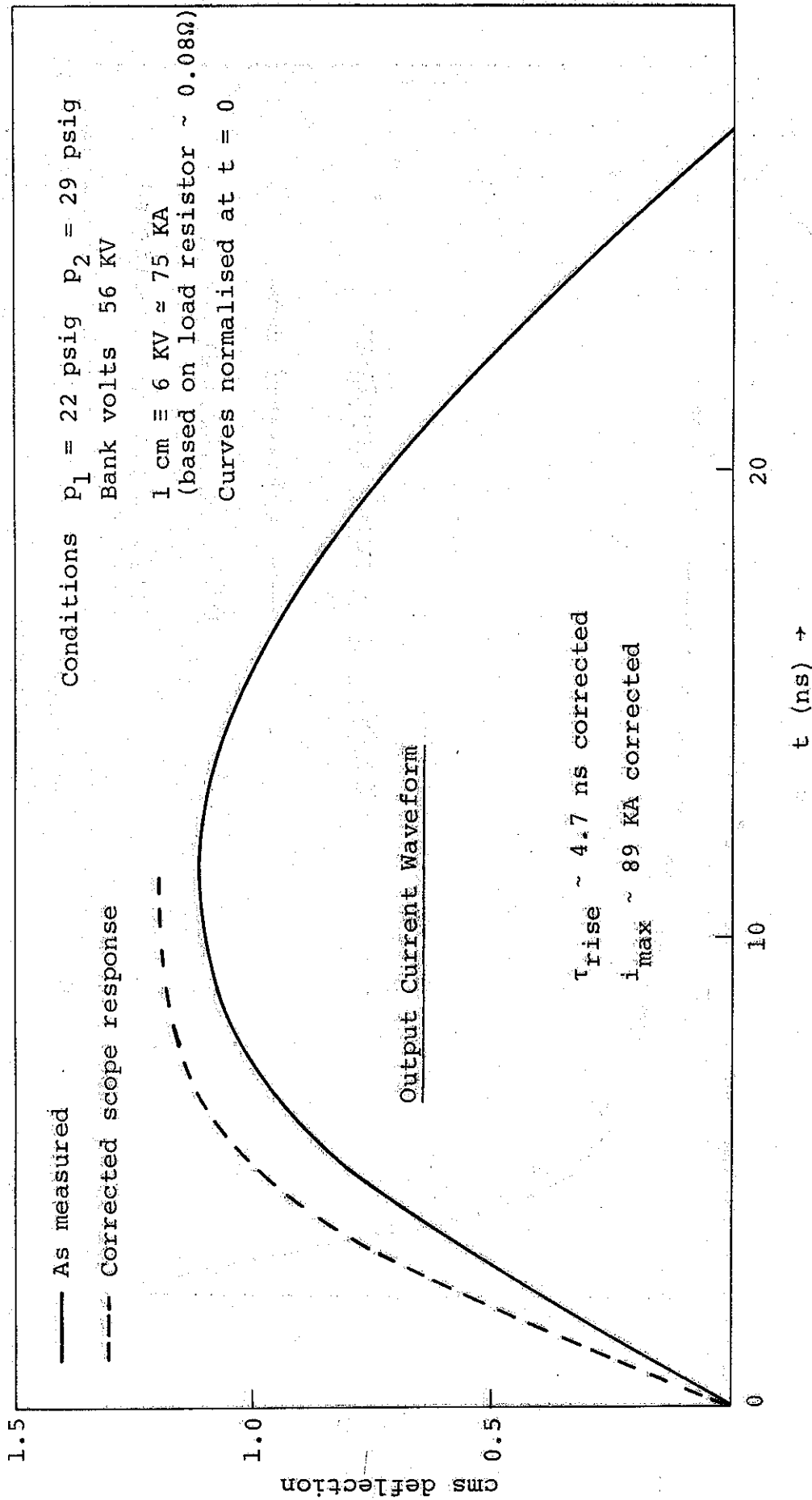

FIGURE 19

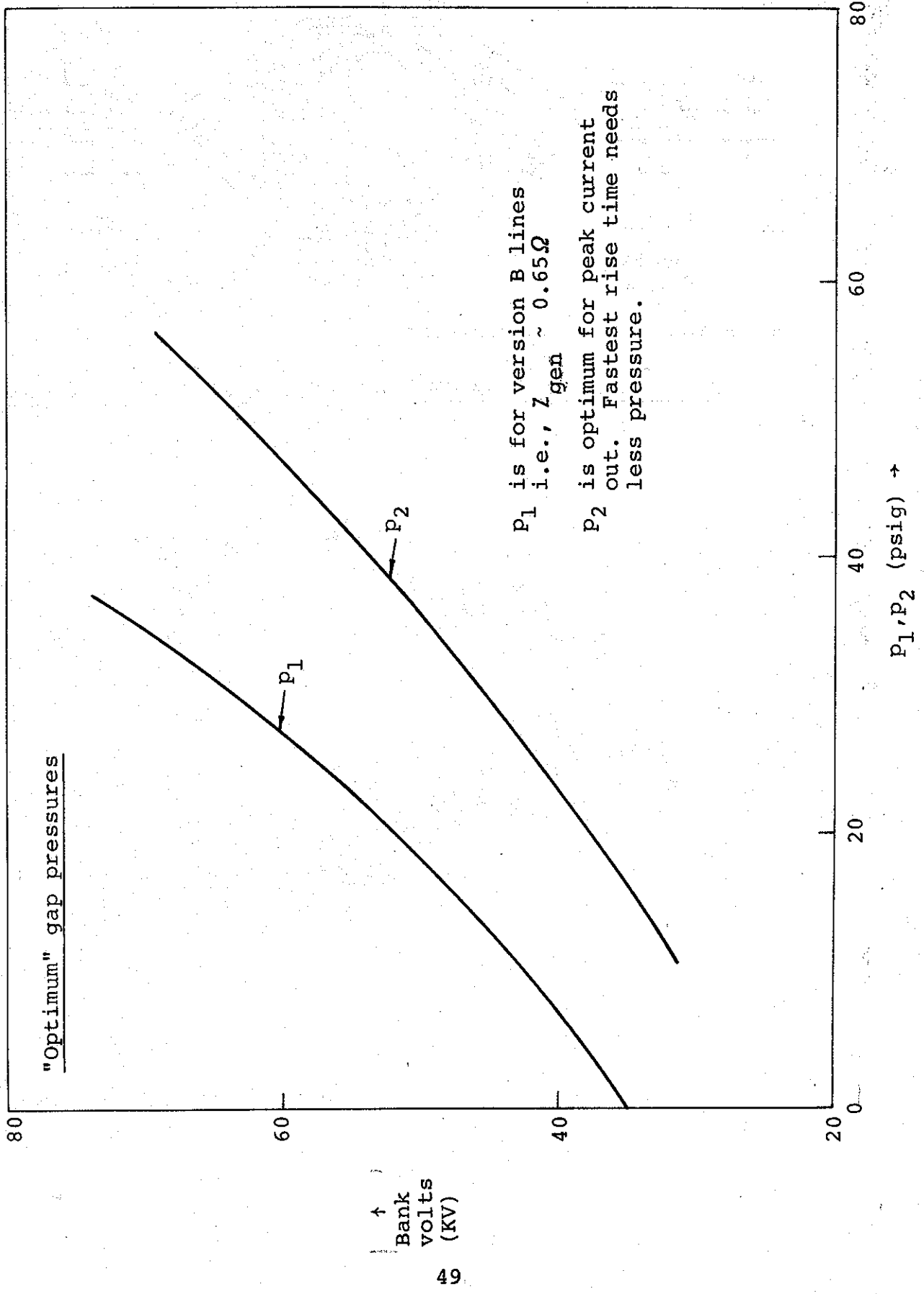
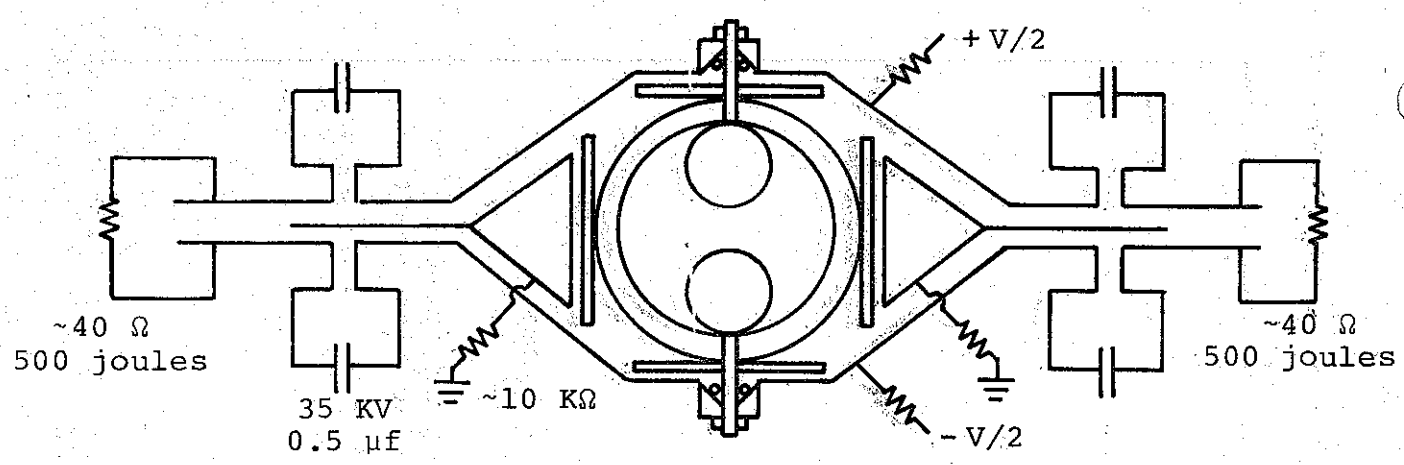
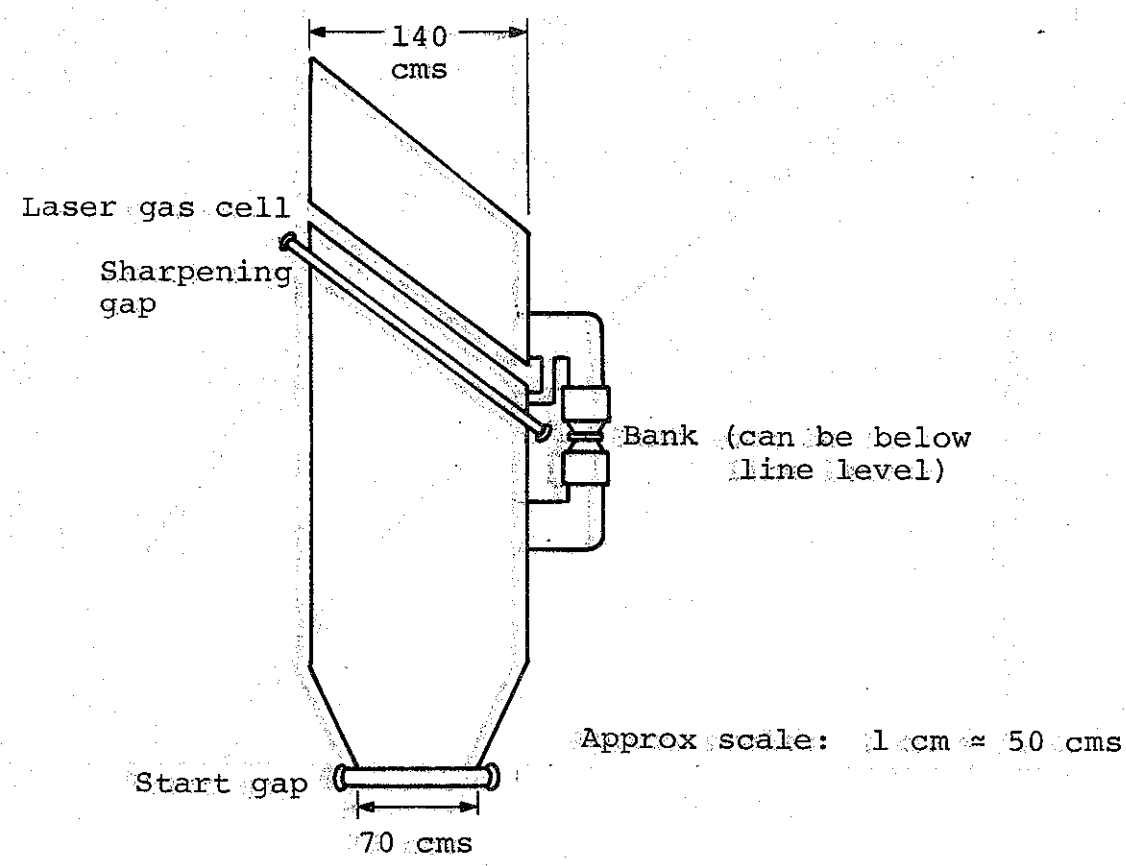

FIGURE 20



Insulation thickness exaggerated

SKETCH OF GAP AND DIAGRAMMATIC LAYOUT OF CAPACITORS FIGURE 21



TOP VIEW OF POSSIBLE LAYOUT FIGURE 22